

Write your name here

Surname	Other names
---------	-------------

Pearson Edexcel
Level 1/Level 2 GCSE (9 - 1)

Centre Number

--	--	--	--	--

Candidate Number

--	--	--	--

Mathematics

Paper 1 (Non-Calculator)

Model Answers

Higher Tier

4BNQMF*TTFTTNFOU.BUFSJBMT0*TTVF

Time: 1 hour 30 minutes

Paper Reference

1MA1/1H

You must have: Ruler graduated in centimetres and millimetres, Total Marks
 protractor, pair of compasses, pen, HB pencil, eraser.

Instructions

- Use **black** ink or ball-point pen.
- **Fill in the boxes** at the top of this page with your name, centre number and candidate number.
- Answer **all** questions.
- Answer the questions in the spaces provided
- – *there may be more space than you need.*
- **Calculators may not be used.**
- Diagrams are **NOT** accurately drawn, unless otherwise indicated.
- You must **show all your working out.**



Information

- The total mark for this paper is 80
- The marks for **each** question are shown in brackets
 – *use this as a guide as to how much time to spend on each question.*

Advice

- Read each question carefully before you start to answer it.
- Keep an eye on the time.
- Try to answer every question.
- Check your answers if you have time at the end.

Turn over ►

S48572A

S48572A0120

©2015 Pearson Education Ltd.

6/4/7/7/4/6/6/

Answer ALL questions.

Write your answers in the spaces provided.

You must write down all the stages in your working.

1 Work out 6.34×5.2

$$\begin{aligned} & (6.34 \times 5) + (6.34 \times 0.2) \\ & \quad \downarrow \qquad \qquad \downarrow \\ & (31.7) + (1.268) = \underline{\underline{32.968}} \end{aligned}$$

$$\begin{array}{r} \times 6.340 \\ 5.200 \\ \hline 0.008 \\ 0.060 \\ 1.200 \\ 0.200 \\ 1.500 \\ 30.000 \\ \hline 32.298 \\ \hline \end{array}$$

32.968

(Total for Question 1 is 3 marks)

2 Expand and simplify $(m + 7)(m + 3)$

$$\begin{aligned} & m^2 + 7m + 3m + 21 \\ & = \underline{\underline{m^2 + 10m + 21}} \end{aligned}$$

$m^2 + 10m + 21$

(Total for Question 2 is 2 marks)

3

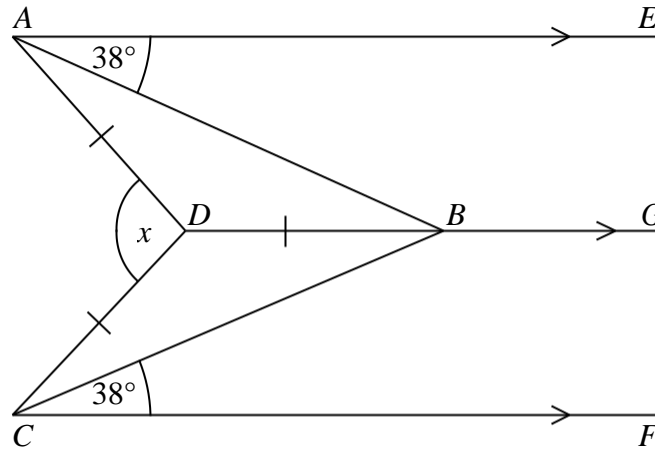

AE , DBG and CF are parallel.

$DA = DB = DC$.

Angle $EAB = \text{angle } BCF = 38^\circ$

Work out the size of the angle marked x .

You must show your working.

$$\angle ABD = 38^\circ \text{ which } = \angle BAD$$

$$\text{So } \angle BDA = 180 - (38 \times 2) = 104^\circ$$

The two triangles are the same so $\angle ADB + \angle CDB = 104 \times 2 = 208^\circ$

$$x = \angle CDA = (360 - 208) = \underline{\underline{152^\circ}}$$

152

(Total for Question 3 is 3 marks)

4 Gary drove from London to Sheffield.
It took him 3 hours at an average speed of 80km/h.

Lyn drove from London to Sheffield.
She took 5 hours.

Assuming that Lyn
drove along the same roads as Gary
and did not take a break,

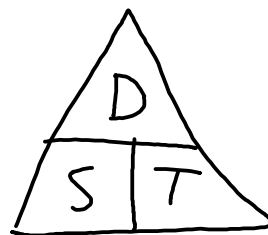

(a) work out Lyn's average speed from London to Sheffield.

First need Gary distance \rightarrow speed \times time $\rightarrow 80 \times 3 = \underline{240 \text{ km}}$

Lyn speed $\rightarrow \frac{\text{distance}}{\text{time}} \rightarrow \frac{240}{5} = \underline{\underline{48 \text{ km/h}}}$

..... 48 km/h
(3)

(b) If Lyn did **not** drive along the same roads as Gary, explain how this could affect your answer to part (a).

..... She would then have driven a different distance to Gary
..... and so her average speed would be different

(1)

(Total for Question 4 is 4 marks)

DO NOT WRITE IN THIS AREA

DO NOT WRITE IN THIS AREA

DO NOT WRITE IN THIS AREA

5 In a company, the ratio of the number of men to the number of women is 3 : 2

40% of the men are under the age of 25

10% of the women are under the age of 25

What percentage of all the people in the company are under the age of 25?

$$\text{Total ratio} = 3+2 = 5$$

$$\begin{aligned} 40\% \text{ of men} &\rightarrow 0.4 \times 3 = 1.2 \\ 10\% \text{ of women} &\rightarrow 0.1 \times 2 = 0.2 \end{aligned} \quad \begin{array}{l} \rightarrow \\ \rightarrow \end{array} = 1.4 \text{ of } 5 \rightarrow \left(\frac{1.4}{5}\right) \times 100 \rightarrow 0.28 \times 100 \\ &= \underline{\underline{28\%}}$$

..... 28 %

(Total for Question 5 is 4 marks)

- 6 The plan, front elevation and side elevation of a solid prism are drawn on a centimetre grid.

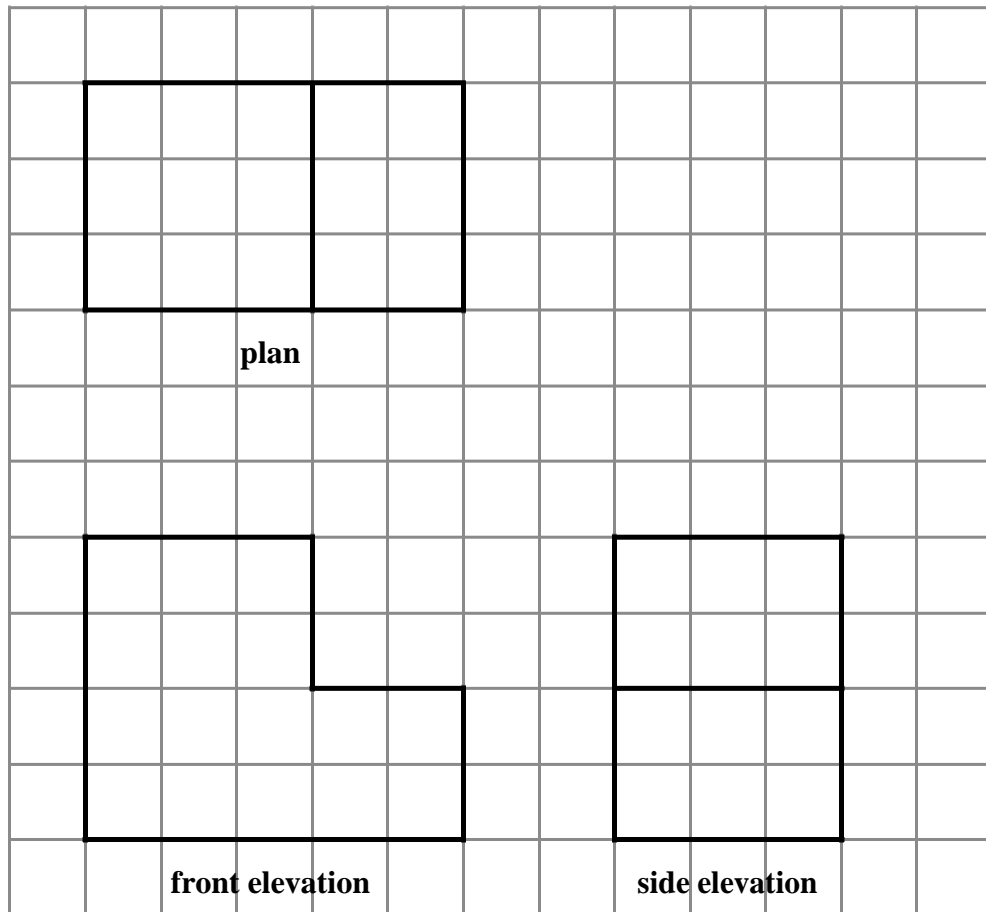

In the space below, draw a sketch of the solid prism.
Write the dimensions of the prism on your sketch.

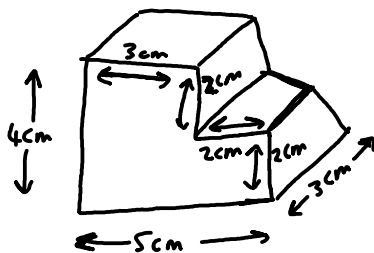

(Total for Question 6 is 2 marks)

DO NOT WRITE IN THIS AREA

DO NOT WRITE IN THIS AREA

DO NOT WRITE IN THIS AREA

7 There are 1200 students at a school.

Kate is helping to organise a party.
She is going to order pizza.

Kate takes a sample of 60 of the students at the school.
She asks each student to tell her **one** type of pizza they want.

The table shows information about her results.

Pizza	Number of students
ham	20
salami	15
vegetarian	8
margarita	17

Work out how much ham pizza Kate should order.

Write down any assumption you make **and** explain how this could affect your answer.

$$\left(\frac{1200}{60}\right) \times 20 \text{ ham} = (20) \times 20 = \underline{\underline{400 \text{ ham pizzas}}}$$

I assumed the sample is representative of the population.

(Total for Question 7 is 3 marks)

8 Here is a parallelogram.

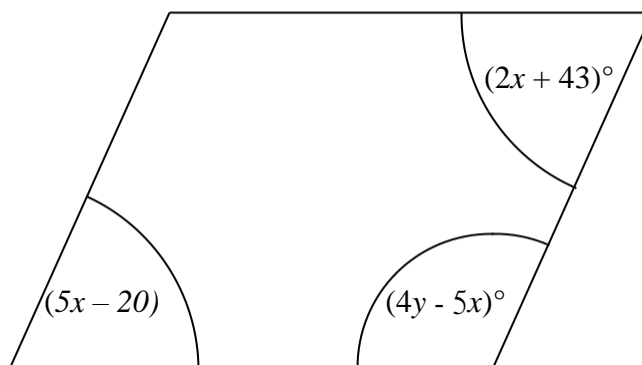

Work out the value of x and the value of y .

Opposite sides of parallelogram are equal so $5x - 20 = 2x + 43$

$$\begin{array}{r} 3x = 63 \\ x = 21 \end{array}$$

Total angle value of parallelogram $= 360^\circ$. So $360^\circ = (5x - 20) + (2x + 43) + 2(4y - 5x)$

$$\begin{aligned} 360^\circ &= (85) + (85) + 8y - 10x \\ 360^\circ &= 170^\circ + 8y - 210^\circ \\ 360^\circ &= 85 - 40^\circ \\ 400^\circ &= 85 \\ \underline{50^\circ} &= y \end{aligned}$$

$$x = 21^\circ$$

$$y = 50^\circ$$

(Total for Question 8 is 5 marks)

DO NOT WRITE IN THIS AREA

DO NOT WRITE IN THIS AREA

DO NOT WRITE IN THIS AREA

- 9 Work out the value of $(9 \times 10^{-4}) \times (3 \times 10^7)$
 7) Give your answer in standard form.

$$(9 \times 3) \times (10^{-4} \times 10^7) \rightarrow (27 \times 10^3) \rightarrow \underline{\underline{(2.7 \times 10^4)}}$$

$$\underline{\underline{2.7 \times 10^4}}$$

(Total for Question 9 is 2 marks)

- 10 (a) Write down the value of $64^{1/2}$

$$64^{1/2} \rightarrow \sqrt{64} = \underline{\underline{8}}$$

8

(1)

- (b) Find the value of $\frac{8^{-2/3}}{125}$

$$\left(\frac{8}{125}\right)^{-2/3} \rightarrow \left(\frac{8}{125}\right)^{3/2} \rightarrow \left(\sqrt[3]{\frac{8}{125}}\right)^2 \rightarrow \left(\frac{2}{5}\right)^2 \rightarrow \underline{\underline{\frac{4}{25}}}$$

4/25

(2)

(Total for Question 10 is 3 marks)

11 One uranium atom has a mass of 3.95×10^{-22} grams.

(a) Work out an estimate for the number of uranium atoms in 1kg of uranium.

Estimate so 4×10^{-22} .

$$\frac{1000 \text{ g}}{4 \times 10^{-22} \text{ g}} \rightarrow (1 \times 10^3) \div (4 \times 10^{-22}) \rightarrow (1 \div 4) \times (10^3 \div 10^{-22})$$

$$= (0.25) \times (10^{25})$$

$$= \underline{\underline{2.5 \times 10^{24}}}$$

$$\underline{\underline{2.5 \times 10^{24}}}$$

(3)

(b) Is your answer to (a) an underestimate or an overestimate?

Give a reason for your answer.

Underestimate as I rounded up the number however it
was in the denominator.

(1)

(Total for Question 11 is 4 marks)

DO NOT WRITE IN THIS AREA

DO NOT WRITE IN THIS AREA

DO NOT WRITE IN THIS AREA

12 Pressure = force/area

Find the pressure exerted by a force of 900 newtons on an area of 60cm^2 .
Give your answer in newtons/ m^2 .

$$60\text{cm} \xrightarrow{\div 100} 0.6\text{m}$$

$$60\text{cm}^2 \xrightarrow{\div 10000} 0.006\text{m}^2$$

$$\frac{900}{0.006} =$$

0.006 goes into 6 1000 times
into 600 100000 times
into 900 150,000 times

150,000

newtons/ m^2

(Total for Question 12 is 2 marks)

13 Rectangle $ABCD$ is mathematically similar to rectangle $DAEF$.

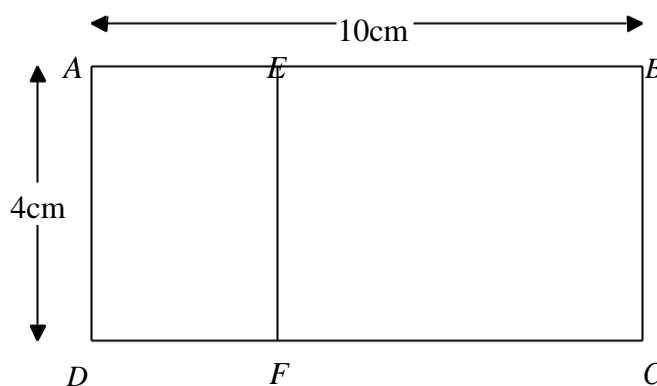

$$AB = 10\text{ cm.}$$

$$AD = 4\text{ cm.}$$

Work out the area of rectangle $DAEF$.

$$\text{Scale factor} \rightarrow 4/10 = 0.4$$

$$4 \times 0.4 = DF = 1.6\text{ cm}$$

$$1.6 \times 4 = \underline{\underline{6.4\text{ cm}^2}}$$

6.4

cm^2

(Total for Question 13 is 3 marks)

14 Ben played 15 games of basketball.
Here are the points he scored in each game.

17 18 18 18 19 20 20 22 23 23 23 26 27 28 28

(a) Draw a box plot for this information.

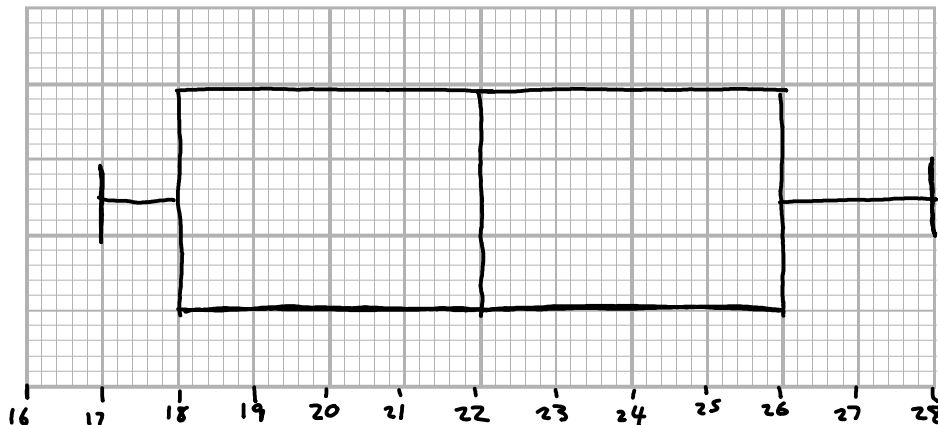

(3)

Sam plays in the same 15 games of basketball.

The median number of points Sam scored is 23

The interquartile range of these points is 12

The range of these points is 20

(b) Who is more consistent at scoring points, Sam or Ben?

You must give a reason for your answer.

Ben is more consistent as IQR is 8 which is less than Sam's IQR of 12. So Ben has a smaller spread of data and is more consistent. His range is also less (11) than Sam (20).

(2)

(Total for Question 14 is 5 marks)

- 15 In a shop, all normal prices are reduced by 20% to give the sale price.

The sale price of a TV set is then reduced by 30%.

Mary says,

“30 + 20 = 50, so this means that the normal price of the TV set has been reduced by 50%.”

Is Mary right?

You must give a reason for your answer.

No, because the total reduction is $0.8 \times 0.7 = 0.44$.

This means the total reduction is 44% and not 50%.

(Total for Question 15 is 2 marks)

- 16 Factorise fully $20x^2 - 5$

$$20x^2 - 5 \rightarrow 5(4x^2 - 1) \rightarrow \underline{\underline{5(2x-1)(2x+1)}}$$

$$5(2x-1)(2x+1)$$

(Total for Question 16 is 2 marks)

- 17 Make a the subject of $a + 3 = \frac{2a + 7}{r}$

$$\begin{aligned} +3 &= \frac{2a+7}{r} \rightarrow r(a+3) = 2a+7 \rightarrow ar+3r = 2a+7 \\ ar-2a &= 7-3r \\ a(r-2) &= 7-3r \\ a &= \frac{7-3r}{r-2} \end{aligned}$$

$$a = \frac{7-3r}{r-2}$$

(Total for Question 17 is 3 marks)

18 Solid A and solid B are mathematically similar.

The ratio of the surface area of solid A to the surface area of solid B is 4:9

The volume of solid B is 405cm^3 .

Show that the volume of solid A is 120cm^3 .

If ratio for area is $2^2:3^2$
 the ratio for volume is $2^3:3^3$

$$\begin{array}{l} A : B \\ \rightarrow 8 : 27 \xrightarrow{\times 15} \\ \xrightarrow{\times 15} \underline{\underline{120 : 405}} \end{array}$$

(Total for Question 18 is 3 marks)

19 Solve $x^2 > 3x + 4$

$$\begin{aligned} x^2 > 3x + 4 &\rightarrow x^2 - 3x - 4 > 0 \\ (x-4)(x+1) &> 0 \\ \underline{\underline{x > 4}} \quad \underline{\underline{x < -1}} \end{aligned}$$

$$\underline{\underline{x > 4 \text{ and } x < -1}}$$

(Total for Question 19 is 3 marks)

DO NOT WRITE IN THIS AREA

DO NOT WRITE IN THIS AREA

DO NOT WRITE IN THIS AREA

20

DO NOT WRITE IN THIS AREA

DO NOT WRITE IN THIS AREA

DO NOT WRITE IN THIS AREA

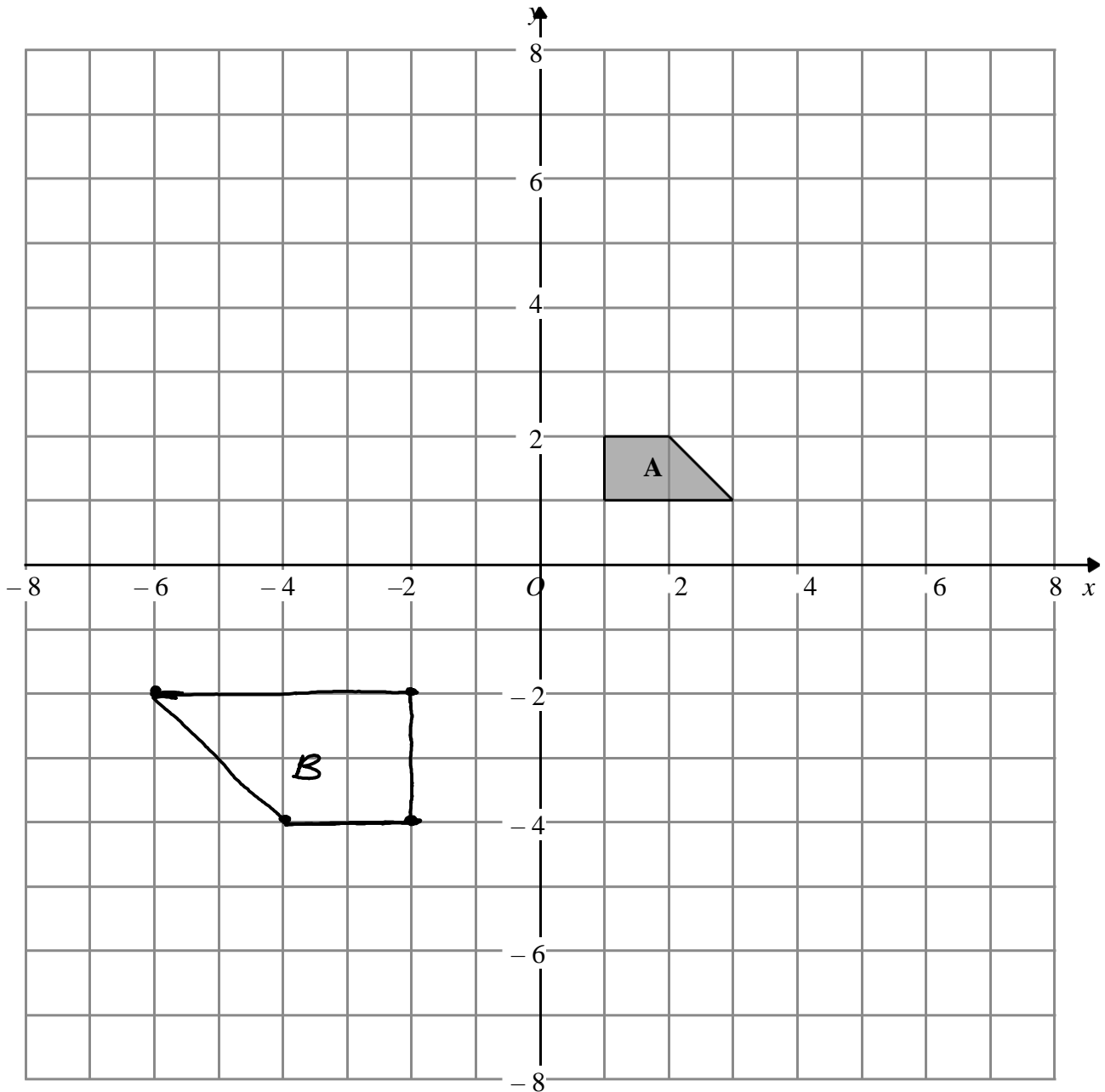

- (a) Enlarge shape **A** by scale factor -2 , centre $(0,0)$
Label your image **B**.

(2)

- (b) Describe fully the single transformation that will map shape **B** onto shape **A**.

Enlargement by scale factor -0.5 from centre $(0,0)$.

(1)

(Total for Question 20 is 3 marks)

21 Here is a speed-time graph for a car journey.
The journey took 100 seconds.

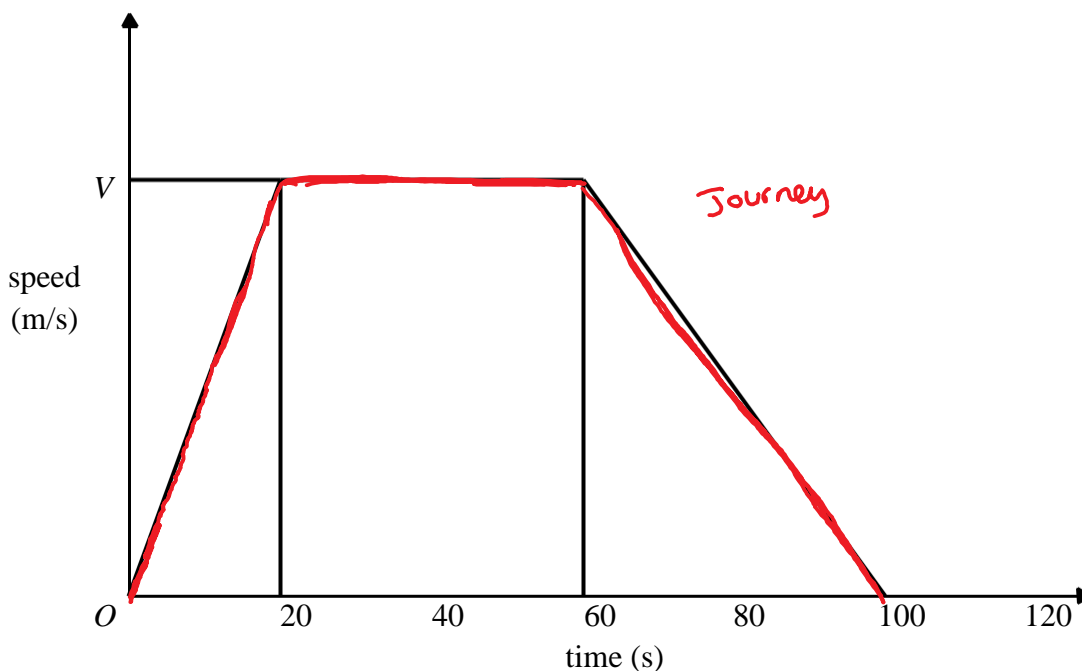

The car travelled 1.75km in the 100 seconds.

(a) Work out the value of V.

Area of graph is distance = 1750m

$$1750 = 10V + 40V + 20V$$

$$1750 = 70V$$

$$\frac{1750}{70} = V = \underline{\underline{25}}$$

$$V = 25$$

(3)

(b) Describe the acceleration of the car for each part of this journey.

First stage acceleration $\rightarrow \frac{25}{20} = \underline{\underline{1.25\text{ms}^{-2}}}$

Second stage no acceleration (constant speed) = $\underline{\underline{0\text{ms}^{-2}}}$

Final stage deceleration $\frac{25}{40} = \underline{\underline{-0.625\text{ms}^{-2}}}$

(2)

(Total for Question 21 is 5 marks)

DO NOT WRITE IN THIS AREA

DO NOT WRITE IN THIS AREA

DO NOT WRITE IN THIS AREA

22 Bhavna recorded the lengths of time, in hours, that some adults watched TV last week.

The table shows information about her results.

Length of time (t hours)	Frequency
$0 \leq t < 10$	6
$10 \leq t < 15$	8
$15 \leq t < 20$	15
$20 \leq t < 40$	5

Bhavna made some mistakes when she drew a histogram for this information.

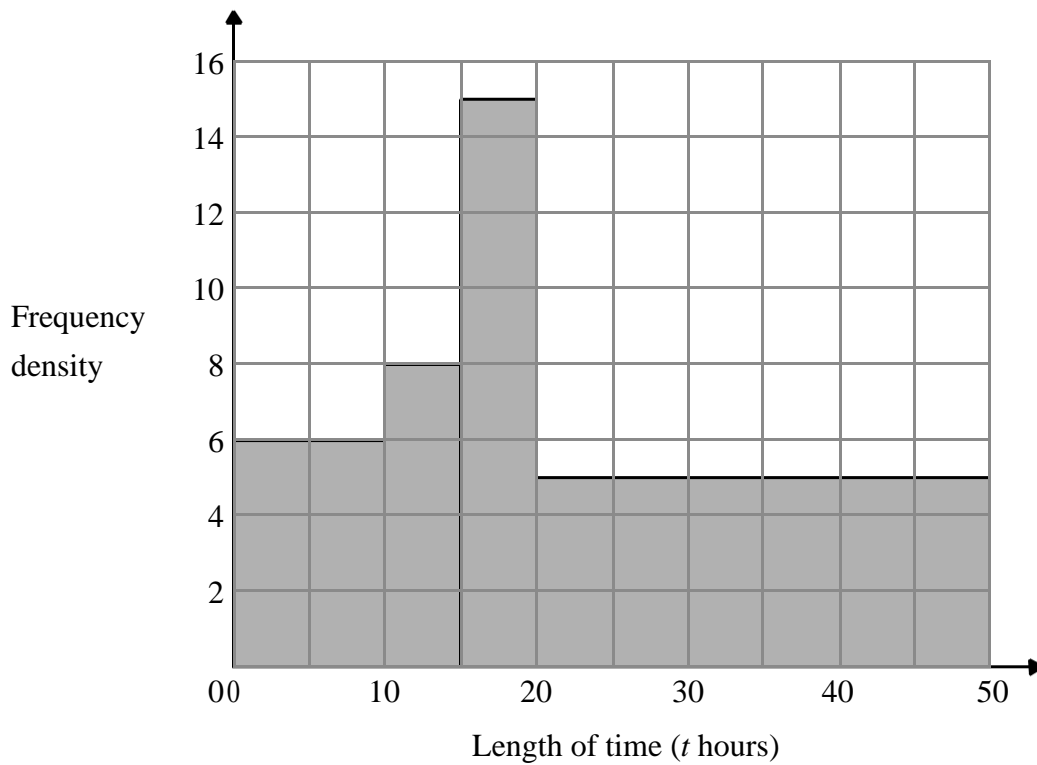

Write down **two** mistakes Bhavna made.

- 1 Areas are not equal to frequencies in table
- 2 Final bar has wrong width of 50. Should be 40

(Total for Question 22 is 2 marks)

DO NOT WRITE IN THIS AREA

DO NOT WRITE IN THIS AREA

DO NOT WRITE IN THIS AREA

23 Show that $\frac{1}{1 + \frac{1}{\sqrt{2}}}$ can be written as $2 - \sqrt{2}$

$$\left(1 + \frac{1}{\sqrt{2}}\right) \rightarrow \frac{\sqrt{2}}{\sqrt{2}} + \frac{1}{\sqrt{2}} \rightarrow \frac{\sqrt{2}+1}{\sqrt{2}}$$

$$1 \div \frac{\sqrt{2}+1}{\sqrt{2}} \rightarrow 1 \times \frac{\sqrt{2}}{\sqrt{2}+1} \rightarrow \frac{\sqrt{2}}{\sqrt{2}+1}$$

$$\frac{\sqrt{2} \times (\sqrt{2}-1)}{(\sqrt{2}+1) \times (\sqrt{2}-1)} \rightarrow \frac{2-\sqrt{2}}{2-1} \rightarrow \underline{\underline{2-\sqrt{2}}}$$

(Total for Question 23 is 3 marks)

DO NOT WRITE IN THIS AREA

DO NOT WRITE IN THIS AREA

DO NOT WRITE IN THIS AREA

24 John has an empty box.

He puts some red counters and some blue counters into the box.

The ratio of the number of red counters to the number of blue counters is 1 : 4

Linda takes at random 2 counters from the box. The

probability that she takes 2 red counters is $\frac{6}{155}$

How many red counters did John put into the box?

$$\frac{x}{5x} \text{ red} \quad \frac{4x}{5x} \text{ blue}$$

$$\frac{x}{5x} \times \frac{x-1}{5x-1} = \frac{6}{155}$$

$$\frac{x^2 - x}{25x^2 - 5x} = \frac{6}{155} \rightarrow 155x^2 - 155x = 150x^2 - 30x$$

$$155x - 155 = 150x - 30$$

$$5x = 125$$

$$\underline{\underline{x = 25}}$$

25

(Total for Question 24 is 4 marks)

- 25 $A(-2,1), B(6, 5)$ and $C(4, k)$ are the vertices of a right-angled triangle ABC .
Angle ABC is the right angle.

Find an equation of the line that passes through A and C .

Give your answer in the form $ay + bx = c$ where a, b and c are integers.

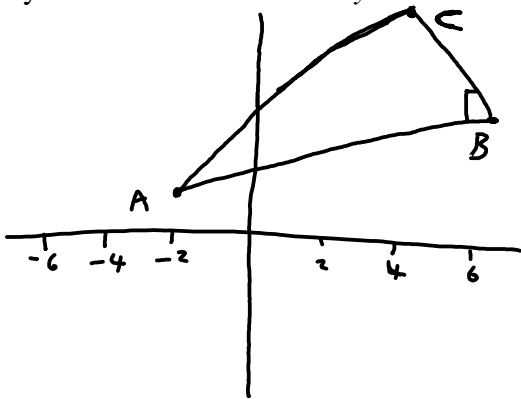

$$\text{Gradient of } AB \rightarrow \frac{5-1}{6-(-2)} = \frac{4}{8} = \frac{1}{2}$$

So gradient of perpendicular BC is $-2 \rightarrow y = -2x + c$

$$BC \text{ goes through point } B \text{ so } \rightarrow (5) = -2(6) + c \rightarrow 5 = -12 + c \rightarrow \underline{c = 17}$$

$$\underline{BC \rightarrow y = -2x + 17}$$

We know point C 's x is 4 so substitute in $BC \rightarrow y = -2(4) + 17 \rightarrow y = 9$

Point C is $(4, 9)$

Line through $A(-2, 1)$ and $C(4, 9)$

$$\text{Gradient } \frac{9-1}{4-(-2)} = \frac{8}{6} = \frac{4}{3} \rightarrow y = \frac{4}{3}x + c$$

$$\text{Goes through } C \text{ so sub in } \rightarrow 9 = \frac{4}{3}(4) + c \rightarrow c = 9 - \frac{16}{3} = \frac{11}{3}$$

$$\underline{y = \frac{4}{3}x + \frac{11}{3} \text{ is line } AC}$$

$$\underline{\underline{\rightarrow 3y - 4x = 11}}$$

$$3y - 4x = 11$$

(Total for Question 25 is 5 marks)

TOTAL FOR PAPER IS 80 MARKS

DO NOT WRITE IN THIS AREA

DO NOT WRITE IN THIS AREA

DO NOT WRITE IN THIS AREA