



**Cambridge International Examinations**  
Cambridge International General Certificate of Secondary Education

CANDIDATE  
NAME

CENTRE  
NUMBER

--	--	--	--

CANDIDATE  
NUMBER

--	--	--	--

**MATHEMATICS**

**0580/31**

Paper 3 (Core)

**October/November 2015**

**2 hours**

Candidates answer on the Question Paper.

Additional Materials:      Electronic calculator  
   Tracing paper (optional)

Geometrical instruments



**READ THESE INSTRUCTIONS FIRST**

Write your Centre number, candidate number and name on all the work you hand in.

Write in dark blue or black pen.

You may use an HB pencil for any diagrams or graphs.

Do not use staples, paper clips, glue or correction fluid.

**DO NOT WRITE IN ANY BARCODES.**

Answer **all** questions.

If working is needed for any question it must be shown below that question.

Electronic calculators should be used.

If the degree of accuracy is not specified in the question, and if the answer is not exact, give the answer to three significant figures. Give answers in degrees to one decimal place.

For  $\pi$ , use either your calculator value or 3.142.

At the end of the examination, fasten all your work securely together.

The number of marks is given in brackets [ ] at the end of each question or part question.

The total of the marks for this paper is 104.

The syllabus is approved for use in England, Wales and Northern Ireland as a Cambridge International Level 1/Level 2 Certificate.

This document consists of **15** printed pages and **1** blank page.

1 (a) 120 children take part in an athletics competition.

(i) Complete the table to show the number of children in each group.

	Girls	Boys	Total
Age 15			65
Age 16	44		
Total	70		120

[2]

(ii) One child is selected at random.

Find the probability that it is a girl aged 16.

Give your answer as a fraction in its lowest terms.

*Answer(a)(ii)* ..... [2]

(iii) Write down the ratio number of girls aged 15 : number of boys aged 15.

Give your answer in its simplest form.

*Answer(a)(iii)* ..... : ..... [2]

(b) Here are the distances, in metres, recorded in the boys' shot putt.

9.23 6.21 9.86 8.64 7.15 7.72 9.01 7.34 6.53 6.89

(i) Find the median.

*Answer(b)(i)* ..... m [2]

(ii) Find the range.

*Answer(b)(ii)* ..... m [1]

(iii) Another boy was a late entry to the competition.

After his attempt, the range increased by 20 cm.

Work out the two possible distances of his attempt.

*Answer(b)(iii)* ..... m or ..... m [2]

2 (a) Write down a number between 20 and 30 that is

(i) a multiple of 6,

*Answer(a)(i)* ..... [1]

(ii) a square number,

*Answer(a)(ii)* ..... [1]

(iii) a cube number,

*Answer(a)(iii)* ..... [1]

(iv) a prime number.

*Answer(a)(iv)* ..... [1]

(b) Find

(i)  $\sqrt[3]{4913}$ ,

*Answer(b)(i)* ..... [1]

(ii)  $3^5$ ,

*Answer(b)(ii)* ..... [1]

(iii)  $6^0$ ,

*Answer(b)(iii)* ..... [1]

(iv)  $2^{-4}$ .

*Answer(b)(iv)* ..... [1]

(c) (i) Write 84 as a product of its prime factors.

*Answer(c)(i)* ..... [2]

(ii) Find the highest common factor (HCF) of 84 and 126.

*Answer(c)(ii)* ..... [2]

- 3 (a) Luis buys a season ticket to watch his local football team.  
The season ticket costs \$595.

- (i) Luis buys the season ticket online and gets a 5% discount on the \$595.

Work out how much Luis pays for the season ticket online.

*Answer(a)(i)* \$..... [2]

- (ii) A ticket to watch one match costs \$38.  
Luis watches 16 matches.

How much did Luis save by buying a season ticket online instead of 16 tickets at \$38 each?

*Answer(a)(ii)* \$..... [2]

- (b) The football stadium has 26 272 seats.  
The number of people who attend one match is 23 854.

Calculate the percentage of the 26 272 seats that are **empty**.

*Answer(b)* ..... % [2]

- (c) The total number of people attending matches at the stadium last season was 506 762.

Write 506 762 in standard form, correct to 3 significant figures.

*Answer(c)* ..... [2]

- (d) Last season the team played a total of 45 matches.  
The table shows the results of these matches.

Result	Number of matches	Pie chart sector angle
Won	20	$160^\circ$
Drawn	15	
Lost	10	

- (i) Complete the table. [3]
- (ii) Complete the pie chart. [1]

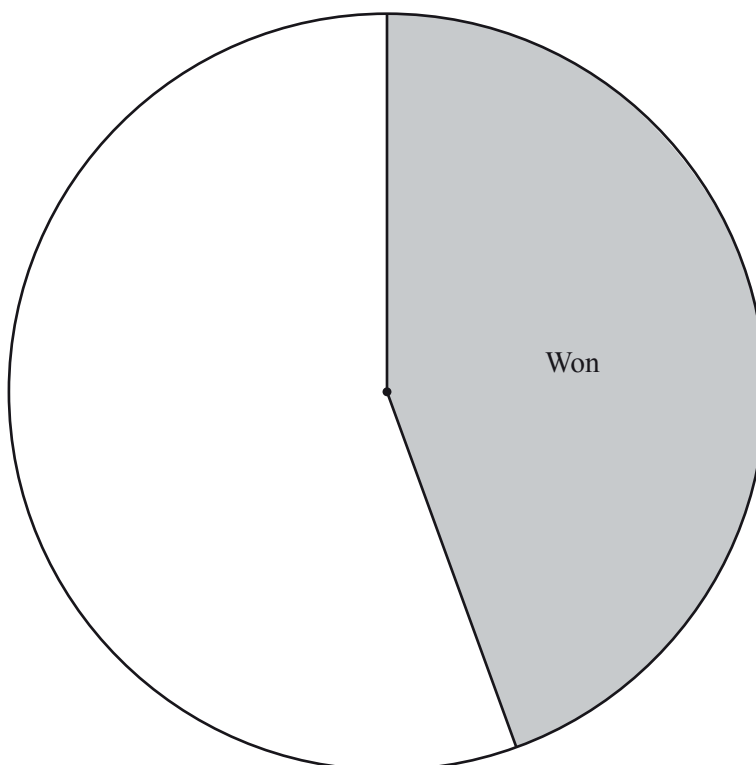

- (e) The table shows the total attendance figures for all the teams in the league for two seasons.

Season	Total attendance
<i>A</i>	$9.76 \times 10^6$
<i>B</i>	$1.36 \times 10^7$

Work out how much greater the attendance was in season *B* than in season *A*.  
Give your answer in standard form.

Answer(e) ..... [2]

- 4 Three friends are going on holiday.  
They travel by plane.

(a) Ahmed's suitcase has mass  $m$  kilograms.

- (i) The mass of Sonia's suitcase is 5 kg more than the mass of Ahmed's suitcase.

Write down an expression, in terms of  $m$ , for the mass of Sonia's suitcase.

*Answer(a)(i)* ..... kg [1]

- (ii) The mass of Hala's suitcase is twice the mass of Ahmed's suitcase.

Write down an expression, in terms of  $m$ , for the mass of Hala's suitcase.

*Answer(a)(ii)* ..... kg [1]

- (iii) The total mass of the three suitcases is 47 kg.

Write down an equation in terms of  $m$ .

*Answer(a)(iii)* ..... [1]

- (iv) Solve your equation and find the mass of each suitcase.

*Answer(a)(iv)* Ahmed's suitcase ..... kg

Sonia's suitcase ..... kg

Hala's suitcase ..... kg [3]

- (b) Each friend carries one bag of hand luggage onto the plane.
- (i) The rule for the maximum size of each bag of hand luggage is

$$\text{length} + \text{width} + \text{height} \leq 115 \text{ cm.}$$

The measurements of Ahmed's bag are shown in the table.

Length	Width	Height
550 mm	395 mm	200 mm

Can Ahmed carry this bag onto the plane? Explain your answer.

*Answer(b)(i)* ..... because .....  
 ..... [2]

- (ii) The mass of Ahmed's bag is 5 kg, correct to the nearest kilogram.

Write down the upper bound of the mass of his bag.

*Answer(b)(ii)* ..... kg [1]

- (c) The friends change money from dollars into euros (€) to spend on holiday.  
 The exchange rate is \$1 = €0.68 .

- (i) Sonia changes \$150 into euros.

Work out how many euros she receives.

*Answer(c)(i)* €..... [1]

- (ii) Hala pays €25.50 for a meal.

Work out how much this is in dollars.

*Answer(c)(ii)* \$..... [2]

- 5 The scale drawing shows two villages, *A* and *B*, joined by a straight road. The scale is 2 centimetres represents 1 kilometre.

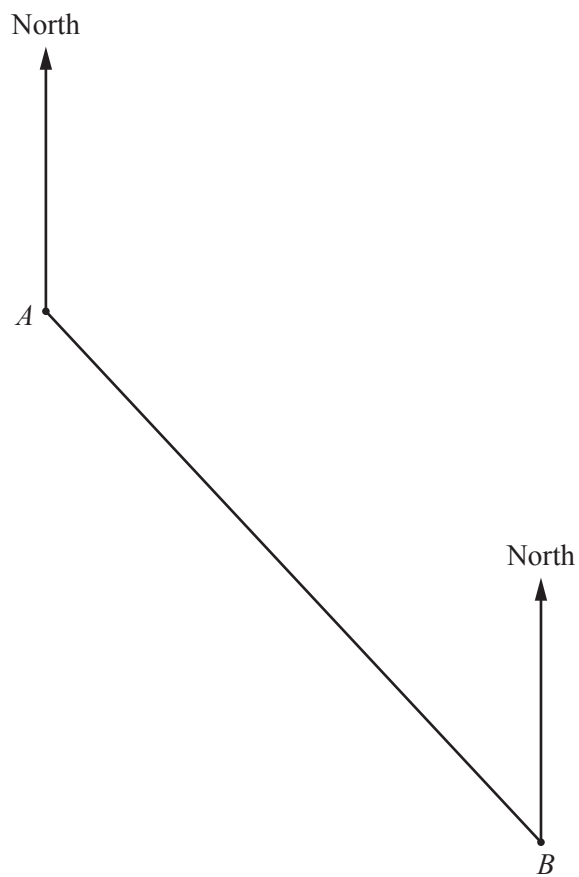

Scale: 2 cm to 1 km



- (a) (i) Work out the distance, in kilometres, from  $A$  to  $B$ .

*Answer(a)(i)* ..... km [2]

- (ii) Measure the bearing of  $B$  from  $A$ .

*Answer(a)(ii)* ..... [1]

- (b) Another village,  $C$ , is 3.2 km from  $A$  on a bearing of  $310^\circ$ .

Mark and label the position of  $C$  on the diagram. [2]

- (c) **In this part use a straight edge and compasses only and show your construction arcs clearly.**

Construct the perpendicular bisector of  $AB$ . [2]

- (d) A school is

- closer to village  $A$  than to village  $B$
- and**
- less than 3 kilometres from village  $B$ .

On the diagram, shade the region in which the school must be. [3]

- (e) Nelson cycles from village  $B$  to the nearest town.  
He cycles a total distance of 12 km at an average speed of 15 km/h.  
He leaves village  $B$  at 10 15.

Work out the time he arrives at the nearest town.

*Answer(e)* ..... [3]

---

6 Irina has some solid building blocks.

(a) Write down the mathematical name of this solid.

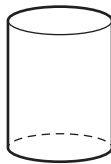

Answer(a) ..... [1]

(b) Irina describes the shape of a different block.

She says:

It has 12 edges and 8 vertices. All the faces are the same shape.

Write down the mathematical name of this solid.

Answer(b) ..... [1]

(c) The diagram shows the end face of another block.

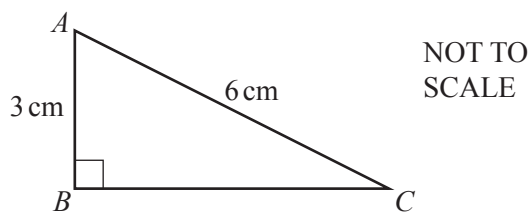

(i) Show that  $BC = 5.2$  cm, correct to 1 decimal place.

Answer(c)(i)

[3]

(ii) Find the area of triangle  $ABC$ .

*Answer(c)(ii)* .....  $\text{cm}^2$  [2]

(iii) This block is a triangular prism with length 8 cm.

Calculate the volume of the block.

*Answer(c)(iii)* .....  $\text{cm}^3$  [1]

(d) The diagram shows another building block.

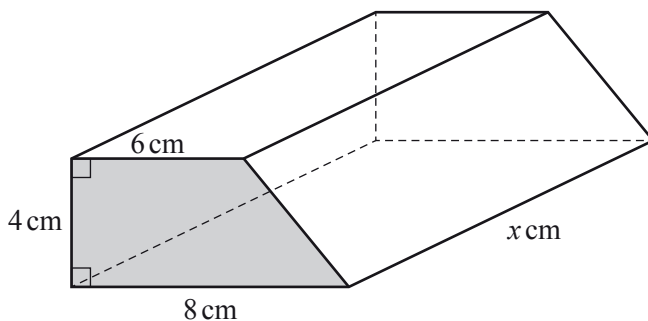

NOT TO SCALE

(i) Calculate the area of the end face of this block.

*Answer(d)(i)* .....  $\text{cm}^2$  [2]

(ii) The volume of this block is  $336 \text{ cm}^3$ .

Find the value of  $x$ .

*Answer(d)(ii)*  $x =$  ..... [1]

- 7 (a) The table shows some values of  $y = \frac{6}{x}$ .

$x$	-5	-4	-3	-2	-1		1	2	3	4	5
$y$	-1.2	-1.5					6		2	1.5	1.2

- (i) Complete the table. [2]
- (ii) On the grid, draw the graph of  $y = \frac{6}{x}$  for  $-5 \leq x \leq -1$  and  $1 \leq x \leq 5$ .

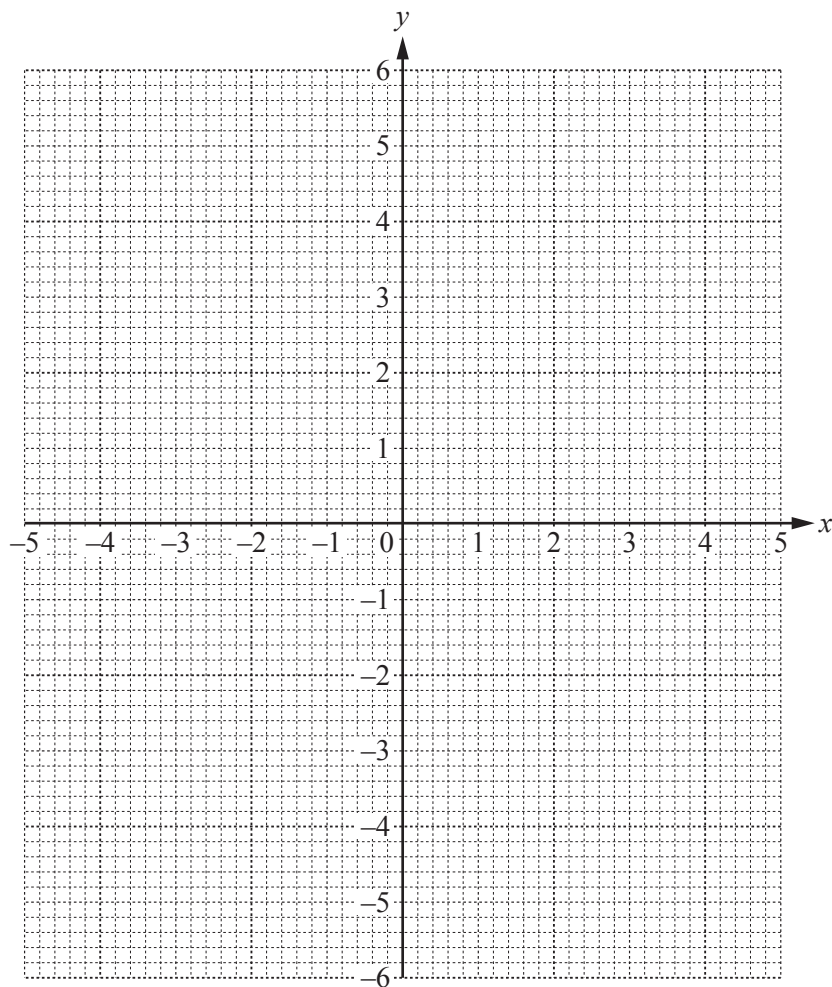

- (iii) On the same grid, draw the line  $y = 4$ . [4]
- (iv) Find the co-ordinates of the point where the line  $y = 4$  crosses the graph of  $y = \frac{6}{x}$ . [1]

Answer(a)(iv) (..... , ..... ) [1]

(b)

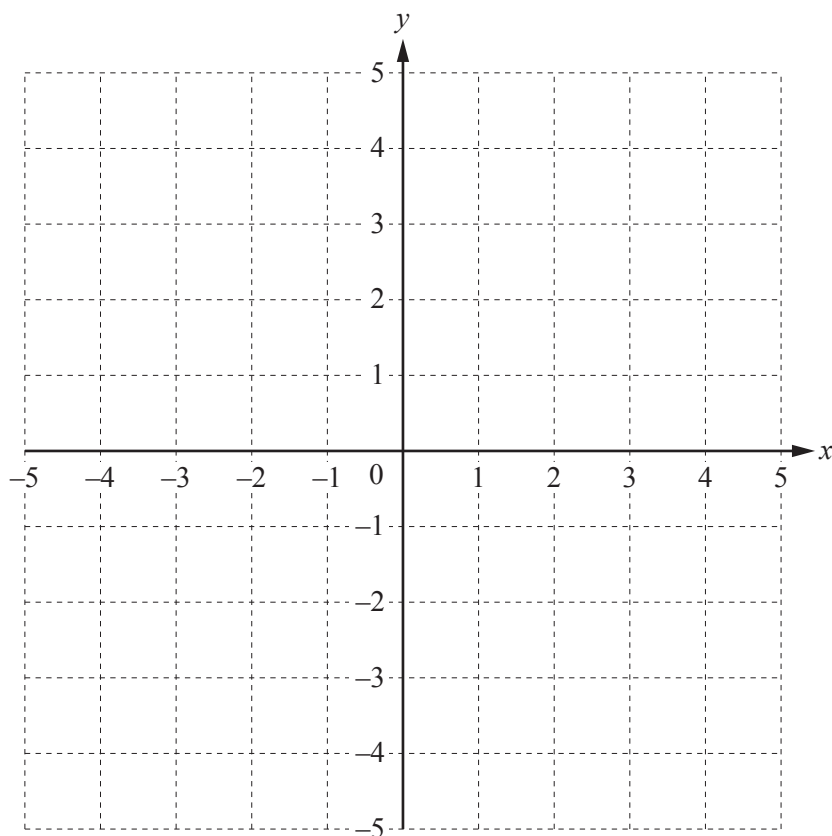

- (i) On this grid, plot the point  $A$   $(-1, -3)$ . [1]
- (ii) Draw a line with gradient 2 through point  $A$ . [1]
- (iii) Write down the equation of your line in the form  $y = mx + c$ .

*Answer(b)(iii)*  $y = \dots\dots\dots$  [2]

---

8 (a)

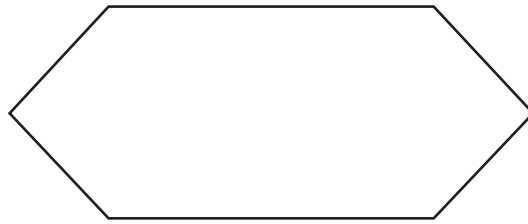

(i) Write down the order of rotational symmetry of this shape.

Answer(a)(i) ..... [1]

(ii) Draw the lines of symmetry on the shape. [2]

(b)

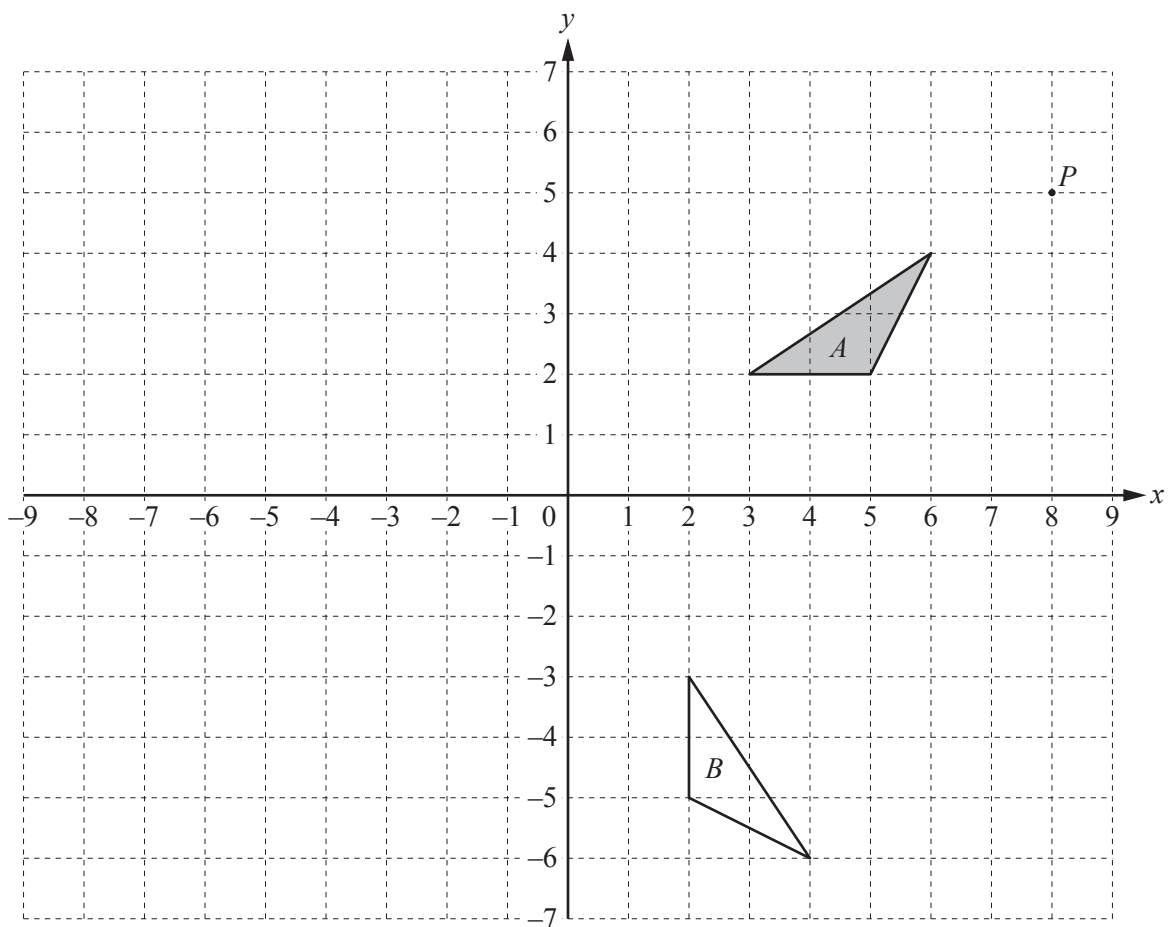

(i) On the grid, reflect triangle *A* in the line  $x = -1$ . [2]

(ii) On the grid, enlarge triangle *A* with centre *P* and scale factor 3. [2]

(iii) Describe fully the **single** transformation that maps triangle *A* onto triangle *B*.

Answer(b)(iii) .....

..... [3]

- 9 (a) Expand and simplify.

$$2(3x + 2) - 4(x + 1)$$

Answer(a) ..... [2]

- (b) Factorise completely.

$$3y^2 - 6y$$

Answer(b) ..... [2]

- (c) Make  $b$  the subject of the formula.

$$a = \frac{b}{4} - 5$$

Answer(c)  $b =$  ..... [2]

- (d) Solve the simultaneous equations.  
You must show all your working.

$$\begin{aligned} 3x + 2y &= 11 \\ 6x - y &= 32 \end{aligned}$$

Answer(d)  $x =$  .....

$y =$  ..... [3]

**BLANK PAGE**

---

Permission to reproduce items where third-party owned material protected by copyright is included has been sought and cleared where possible. Every reasonable effort has been made by the publisher (UCLES) to trace copyright holders, but if any items requiring clearance have unwittingly been included, the publisher will be pleased to make amends at the earliest possible opportunity.

To avoid the issue of disclosure of answer-related information to candidates, all copyright acknowledgements are reproduced online in the Cambridge International Examinations Copyright Acknowledgements Booklet. This is produced for each series of examinations and is freely available to download at [www.cie.org.uk](http://www.cie.org.uk) after the live examination series.

Cambridge International Examinations is part of the Cambridge Assessment Group. Cambridge Assessment is the brand name of University of Cambridge Local Examinations Syndicate (UCLES), which is itself a department of the University of Cambridge.