



Please write clearly in block capitals.

Centre number

--	--	--	--	--

Candidate number

--	--	--	--

Surname

Forename(s)

Candidate signature

GCSE MATHEMATICS

H

Higher Tier Unit 3 Geometry and Algebra

Tuesday 10 November 2015

Morning

Time allowed: 1 hour 30 minutes

Materials

For this paper you must have:

- a calculator
- mathematical instruments.



Instructions

- Use black ink or black ball-point pen. Draw diagrams in pencil.
- Answer **all** questions.
- You must answer the questions in the spaces provided. Do not write outside the box around each page or on blank pages.
- Do all rough work in this book. Cross through any work that you do not want to be marked.
- If your calculator does not have a π button, take the value of π to be 3.14 unless another value is given in the question.

Information

- The marks for questions are shown in brackets.
- The maximum mark for this paper is 80.
- Quality of written communication is specifically assessed in Questions 3 and 6. These questions are indicated with an asterisk (*).
- You may ask for more answer paper, graph paper and tracing paper. These must be tagged securely to this answer book.

Advice

- In all calculations, show clearly how you work out your answer.



N 0 V 1 5 4 3 6 0 3 H 0 1

WMP/Nov15/43603H/E7

43603H

Formulae Sheet: Higher Tier

Area of trapezium = $\frac{1}{2}(a+b)h$

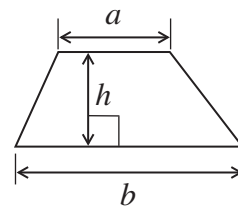

Volume of prism = area of cross-section \times length

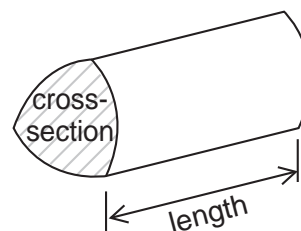

Volume of sphere = $\frac{4}{3}\pi r^3$

Surface area of sphere = $4\pi r^2$

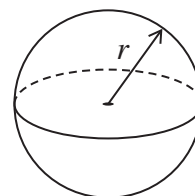

Volume of cone = $\frac{1}{3}\pi r^2 h$

Curved surface area of cone = $\pi r l$

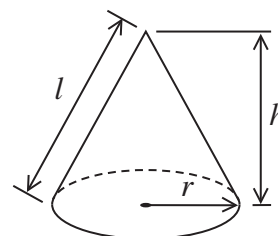

In any triangle ABC

Area of triangle = $\frac{1}{2}ab \sin C$

Sine rule $\frac{a}{\sin A} = \frac{b}{\sin B} = \frac{c}{\sin C}$

Cosine rule $a^2 = b^2 + c^2 - 2bc \cos A$

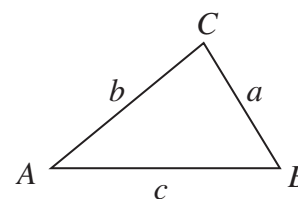

The Quadratic Equation

The solutions of $ax^2 + bx + c = 0$, where $a \neq 0$, are given by

$$x = \frac{-b \pm \sqrt{b^2 - 4ac}}{2a}$$



Answer **all** questions in the spaces provided.

1 Work out the area of this pentagon.

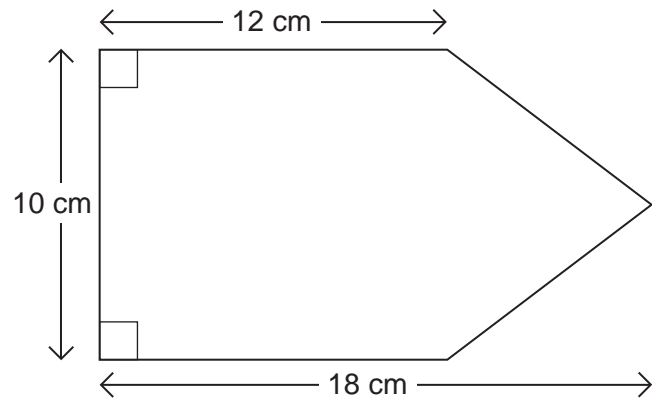

Not drawn accurately

[3 marks]

.....

.....

.....

.....

.....

.....

Answer cm²

3

Turn over ►



2 (a) Enlarge this shape by scale factor 2 with centre of enlargement point P .

[3 marks]

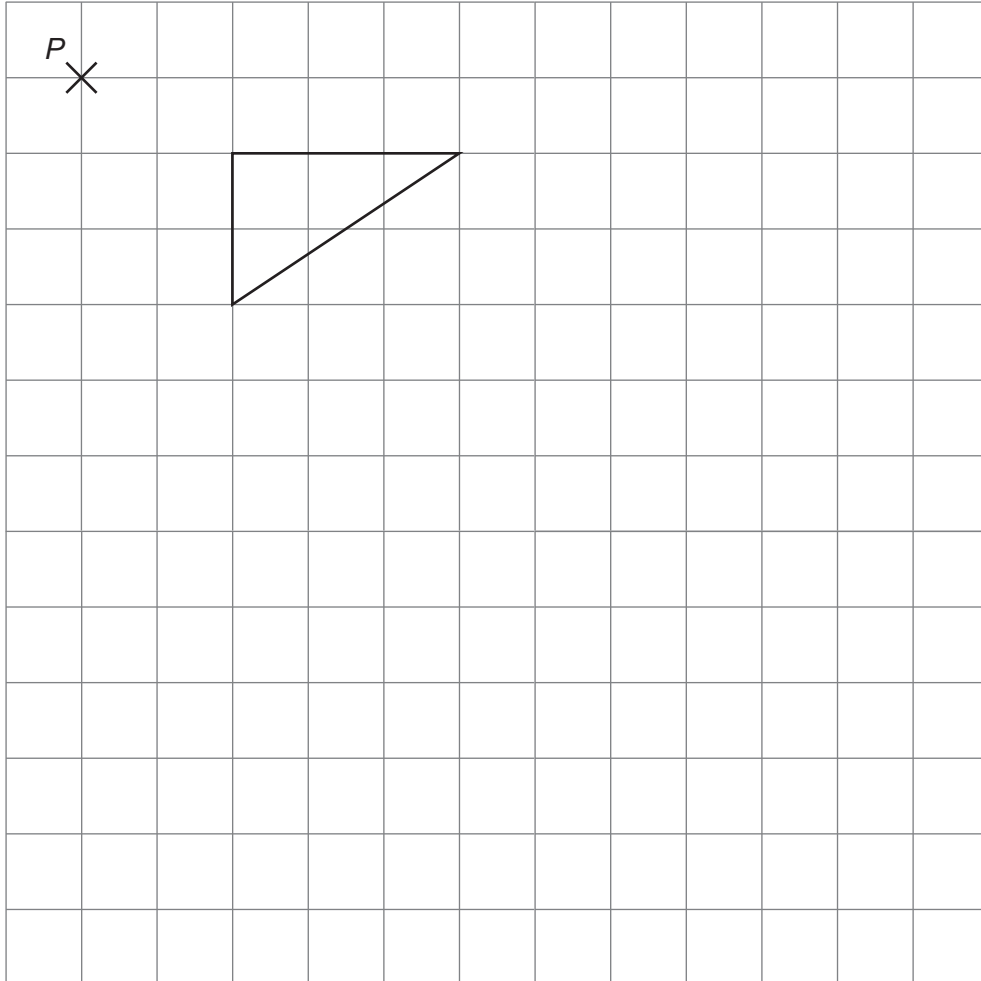

2 (b) Describe fully the **single** transformation that maps shape A to shape B.

[3 marks]

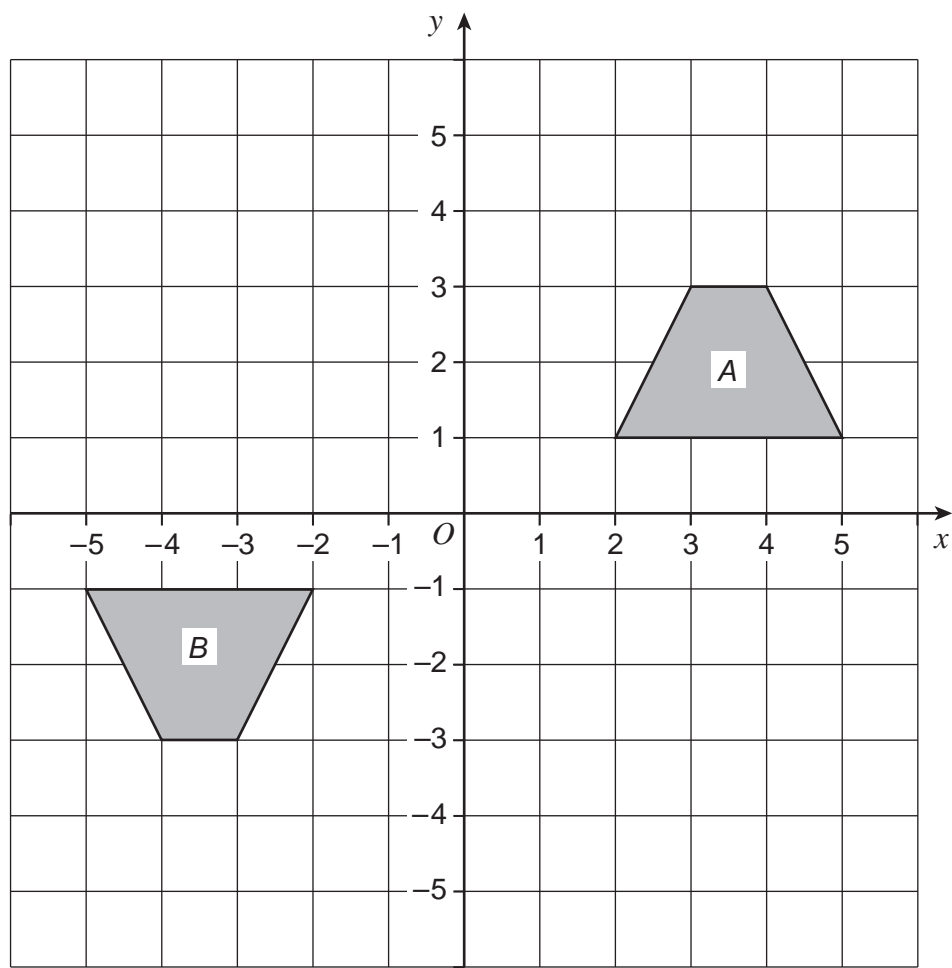

.....

.....

.....

Turn over ►



*3 A gardener uses this formula to work out how much he charges to make a lawn.

$$C = \frac{7(14 + A)}{3}$$

C is the charge in £

A is the area in m^2

He makes a rectangular lawn measuring 12.5 m by 17.6 m

How much does he charge?

[3 marks]

.....

.....

.....

.....

.....

.....

Answer £



4 The diagram shows a water tank in the shape of a cuboid.

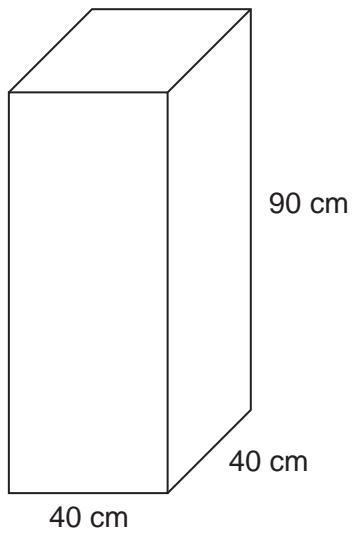

The tank is full of water.

1 litre = 1000 cm³

How many gallons of water are in the tank?

[4 marks]

.....

.....

.....

.....

.....

.....

Answer gallons

7

Turn over ►



- 5 The diagram shows three straight lines.

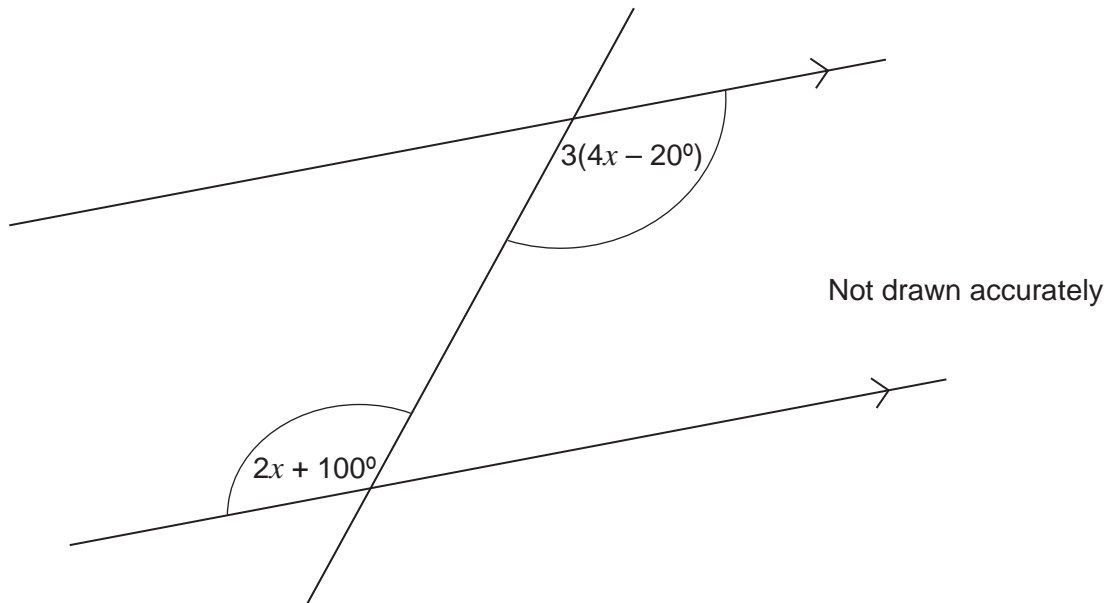

- 5 (a) Which of the following describes the pair of angles marked?
Circle your answer.

[1 mark]

Alternate

Corresponding

Interior

Vertically opposite



5 (b) Work out the value of x .

[4 marks]

.....

.....

.....

.....

.....

.....

.....

.....

$x =$ degrees

Turn over for the next question

5

Turn over ►



*6 Washing powder is sold in two sizes, 600 grams and 1500 grams.

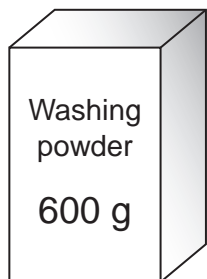

£3.30



Was £9.60
Now 15% off

Which size is better value for money?
You **must** show your working.

[6 marks]

.....

.....

.....

.....

.....

.....

.....

.....

.....

.....

Answer



8 (a) Complete the table of values for $y = 3 - x^2$

[2 marks]

x	-3	-2	-1	0	1	2	3
y		-1	2		2		-6

8 (b) Draw the graph of $y = 3 - x^2$ for values of x from -3 to 3

[2 marks]

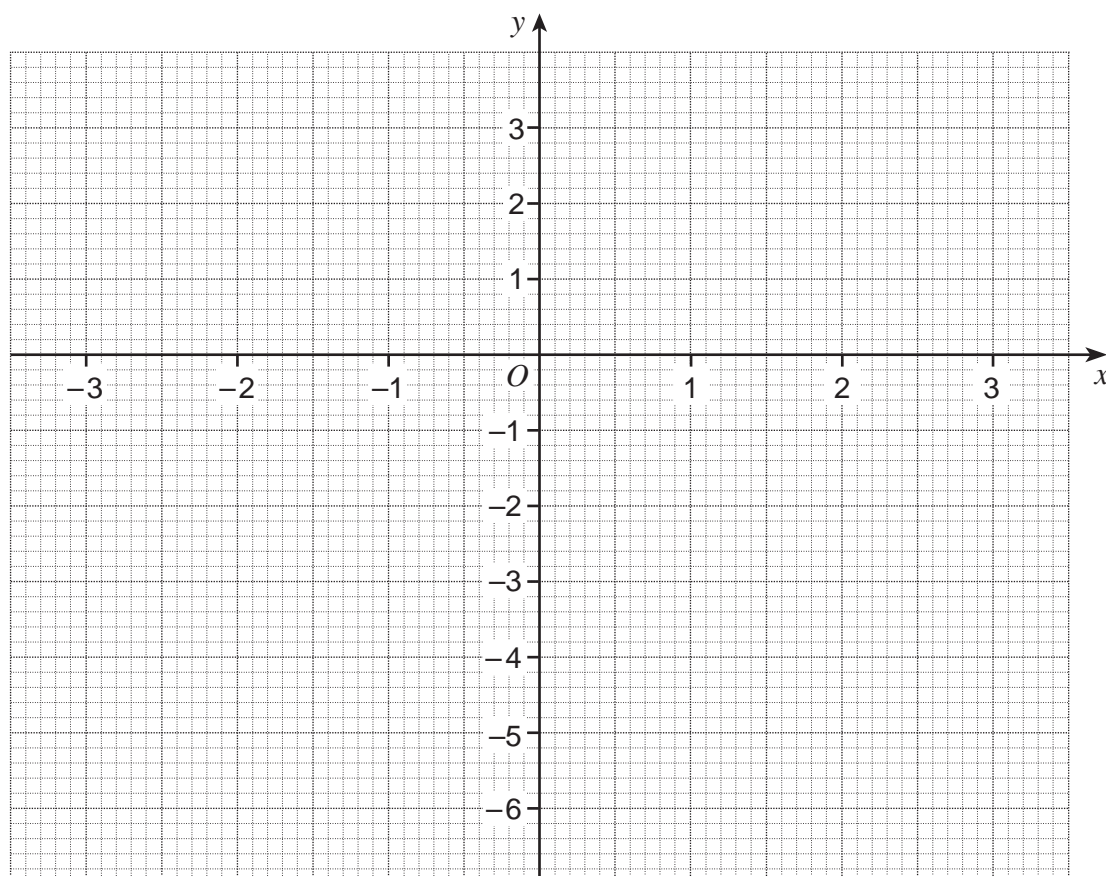

8 (c) Use the graph to work out the values of x when $y = -1.5$

[2 marks]

.....

.....

Answer and

9

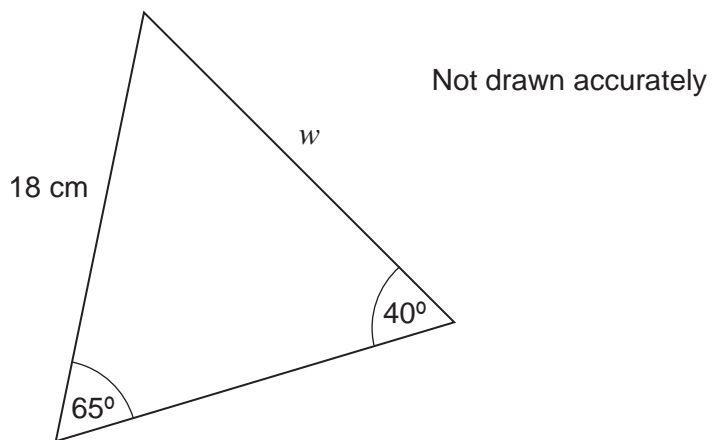

Work out the length w .

[3 marks]

.....

.....

.....

.....

.....

.....

Answer cm

9

Turn over ►



10 (a) A, B and C are points on a circle, centre O.

Not drawn accurately

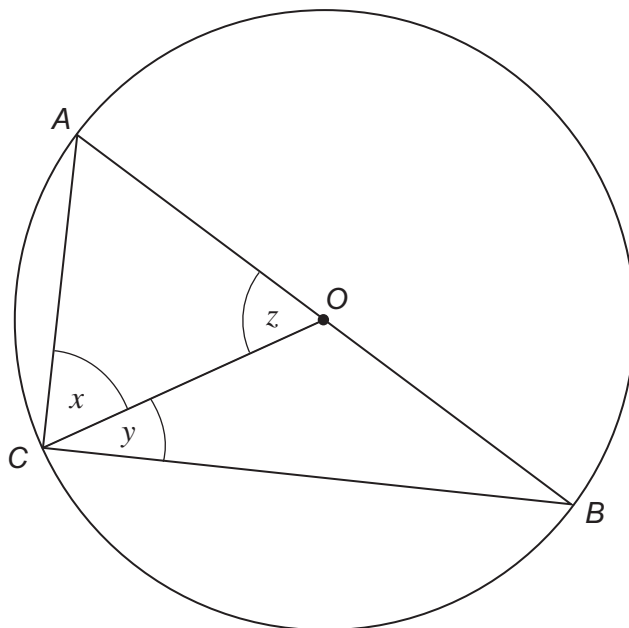

AB is a diameter.

The ratio of the size of angle x to the size of angle y is

$$x : y = 5 : 1$$

Work out the size of angle z .

[3 marks]

.....

.....

.....

.....

.....

Answer degrees



10 (b) *L, M and N are points on a circle.
PLQ is a tangent.*

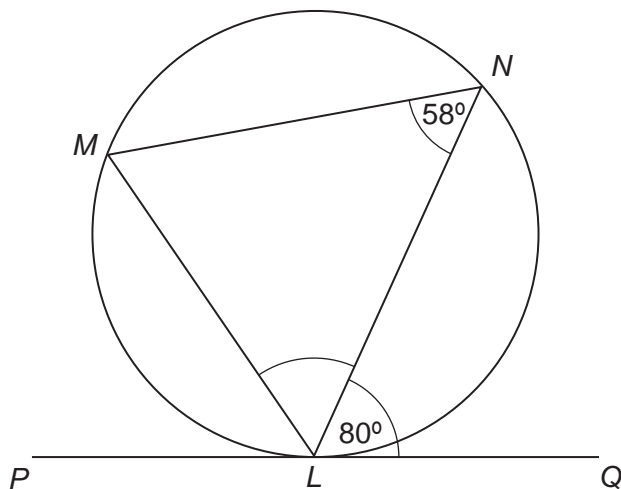

Not drawn accurately

Work out angle *MLN*.

[3 marks]

.....

.....

.....

Answer degrees

Turn over for the next question



11 A and B are similar triangles.
All measurements are in centimetres.

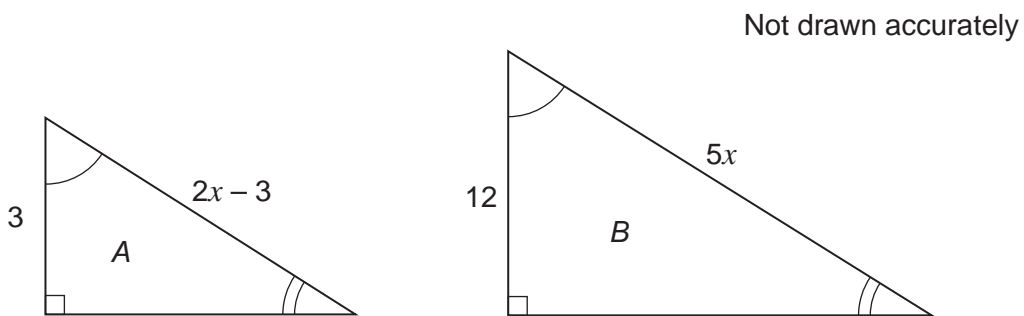

Work out the area of triangle B.

[7 marks]

.....

.....

.....

.....

.....

.....

.....

.....

.....

.....

.....

.....

.....

.....

.....

.....

.....

.....

.....

.....

Answer cm^2



12 Solve $5x^2 + 3x - 4 = 0$

Give your answers to 2 decimal places.

[3 marks]

.....

.....

.....

.....

.....

.....

.....

.....

Answer and

Turn over for the next question

10

Turn over ►



13 The diagram shows a sphere made of wood.

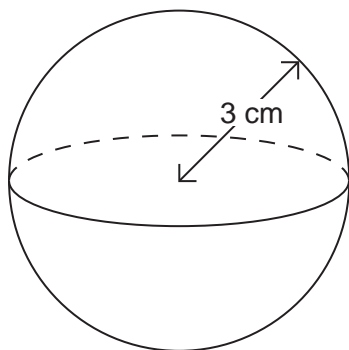

The radius of the sphere is 3 cm
The mass of the sphere is 85 grams.

Work out the density of the wood.

[3 marks]

.....

.....

.....

.....

.....

.....

Answer grams / cm³



14 The diagram shows a quadrilateral.

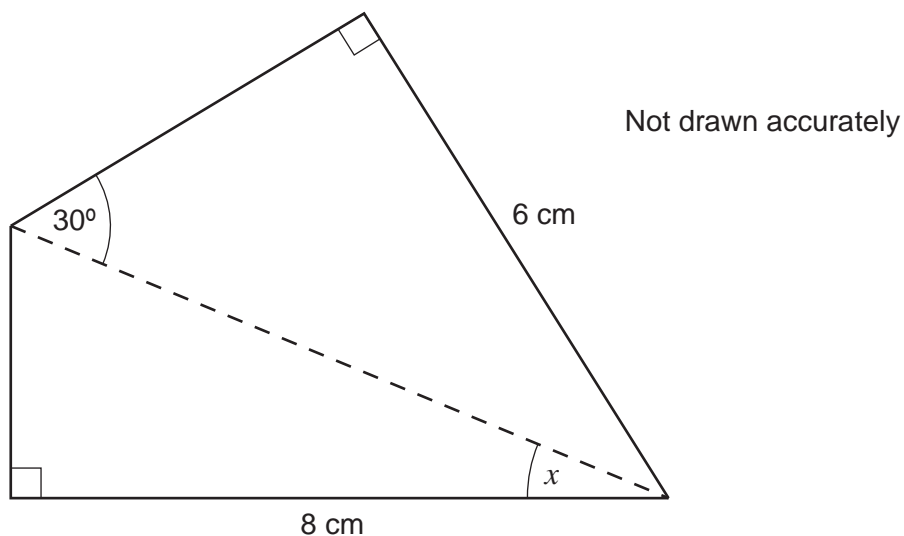

Work out the size of angle x .

[4 marks]

.....

.....

.....

.....

.....

.....

.....

.....

.....

.....

.....

Answer degrees

7

Turn over ►



15

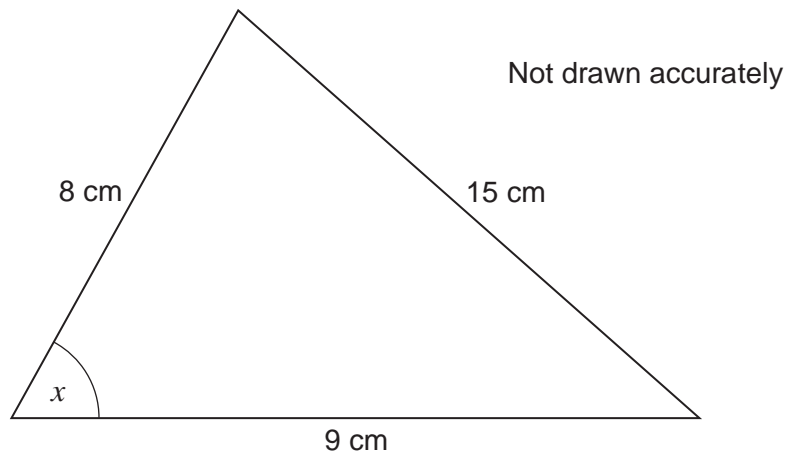

15 (a) Which equation is correct for the triangle?
Circle your answer.

[1 mark]

$$\cos x = \frac{15^2 - 8^2 - 9^2}{2 \times 8 \times 9}$$

$$\cos x = \frac{8^2 + 9^2 - 15^2}{15 \times 8 \times 9}$$

$$\cos x = \frac{8^2 + 9^2 - 15^2}{2 \times 8 \times 9}$$

$$\cos x = \frac{15^2 - 8^2 + 9^2}{15 \times 8 \times 9}$$

15 (b) Use your calculator to work out the value of x in your equation.

[1 mark]

.....

.....

.....

Answer degrees



16

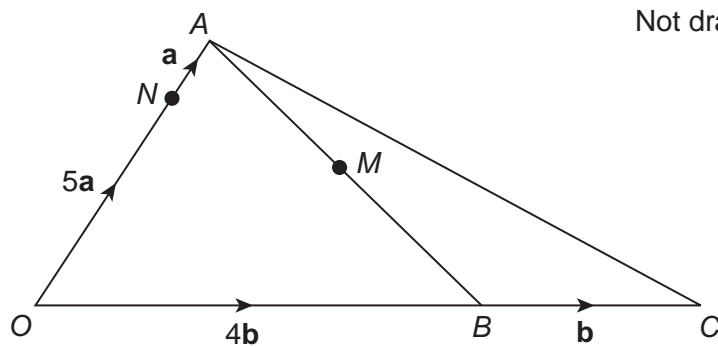

$\vec{ON} = 5\mathbf{a}$ $\vec{NA} = \mathbf{a}$

$\vec{OB} = 4\mathbf{b}$ $\vec{BC} = \mathbf{b}$

M is the midpoint of AB.

16 (a) Show that $\vec{NM} = 2(\mathbf{b} - \mathbf{a})$ [2 marks]

.....

.....

.....

16 (b) Work out the ratio $NM : NC$ [2 marks]

.....

.....

.....

.....

.....

Answer :

6

Turn over ►



17 The diagram shows a sector of a circle, centre O , radius 18 cm

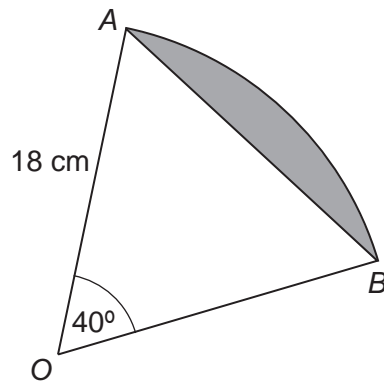

Not drawn accurately

Work out the area of the shaded segment.

[3 marks]

.....

.....

.....

.....

.....

.....

.....

Answer cm^2



There are no questions printed on this page

**DO NOT WRITE ON THIS PAGE
ANSWER IN THE SPACES PROVIDED**

Copyright Information

For confidentiality purposes, from the November 2015 examination series, acknowledgements of third party copyright material will be published in a separate booklet rather than including them on the examination paper or support materials. This booklet is published after each examination series and is available for free download from www.aqa.org.uk after the live examination series.

Permission to reproduce all copyright material has been applied for. In some cases, efforts to contact copyright-holders may have been unsuccessful and AQA will be happy to rectify any omissions of acknowledgements. If you have any queries please contact the Copyright Team, AQA, Stag Hill House, Guildford, GU2 7XJ.

Copyright © 2015 AQA and its licensors. All rights reserved.

