

Centre Number						Candidate Number				
Surname										
Other Names										
Candidate Signature										



General Certificate of Secondary Education  
Foundation Tier  
November 2013

# Mathematics

# 43603F

## Unit 3

Monday 11 November 2013 9.00 am to 10.30 am

# F

<p><b>For this paper you must have:</b></p> <ul style="list-style-type: none"> <li>• a calculator</li> <li>• mathematical instruments.</li> </ul>	
---	--

### Time allowed

- 1 hour 30 minutes

### Instructions

- Use black ink or black ball-point pen. Draw diagrams in pencil.
- Fill in the boxes at the top of this page.
- Answer **all** questions.
- You must answer the questions in the spaces provided. Do not write outside the box around each page or on blank pages.
- Do all rough work in this book.
- If your calculator does not have a  $\pi$  button, take the value of  $\pi$  to be 3.14 unless another value is given in the question.

### Information

- The marks for questions are shown in brackets.
- The maximum mark for this paper is 80.
- The quality of your written communication is specifically assessed in Questions 10 and 15. These questions are indicated with an asterisk (\*).
- You may ask for more answer paper, graph paper and tracing paper. These must be tagged securely to this answer booklet.

### Advice

- In all calculations, show clearly how you work out your answer.

For Examiner's Use	
Examiner's Initials	
Pages	Mark
3	
4 – 5	
6 – 7	
8 – 9	
10 – 11	
12 – 13	
14 – 15	
16 – 17	
18 – 19	
20 – 21	
22 – 23	
24	
<b>TOTAL</b>	



N 0 V 1 3 4 3 6 0 3 F 0 1

WMP/Nov13/43603F/E4

# 43603F

**Formulae Sheet: Foundation Tier**

**Area of trapezium** =  $\frac{1}{2}(a+b)h$

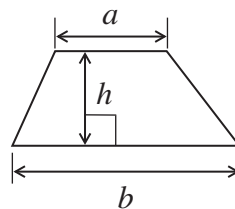

**Volume of prism** = area of cross-section  $\times$  length

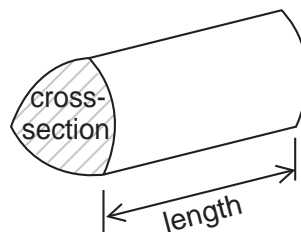

Answer **all** questions in the spaces provided.

1 Here are four rods.

Not drawn accurately

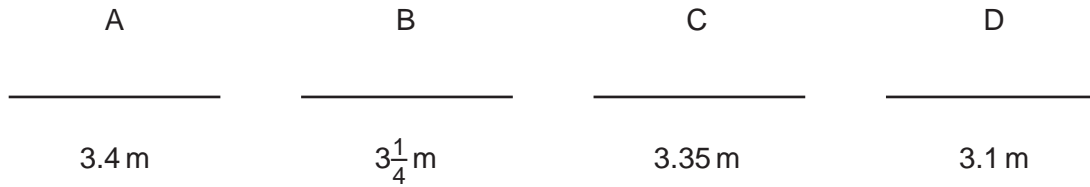

1 (a) Which rod is the longest?

Answer ..... (1 mark)

1 (b) Work out the total length of rod C and rod D.

.....

Answer ..... m (1 mark)

1 (c) Which **three** rods have a total length of 10 metres?

.....  
.....  
.....

Answer ..... and ..... and ..... (2 marks)

4

Turn over ►



2 Here are six words that are used with circles.

arc      chord      diameter      sector      segment      tangent

Put the correct word from the list in each box.

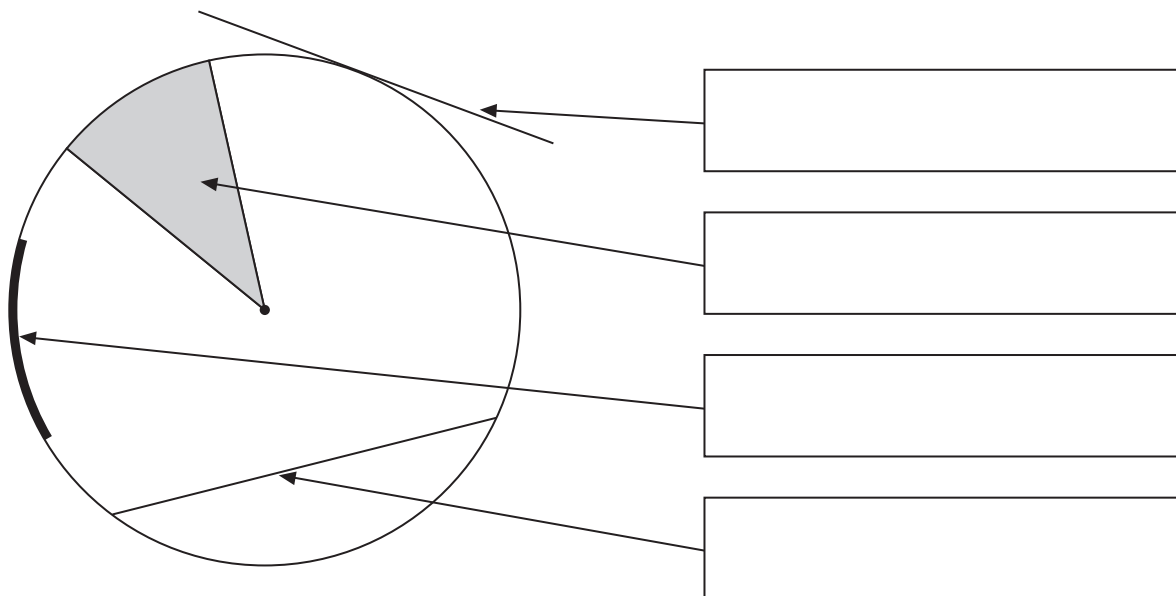

(4 marks)



3 A straight road connects Bristol and London.

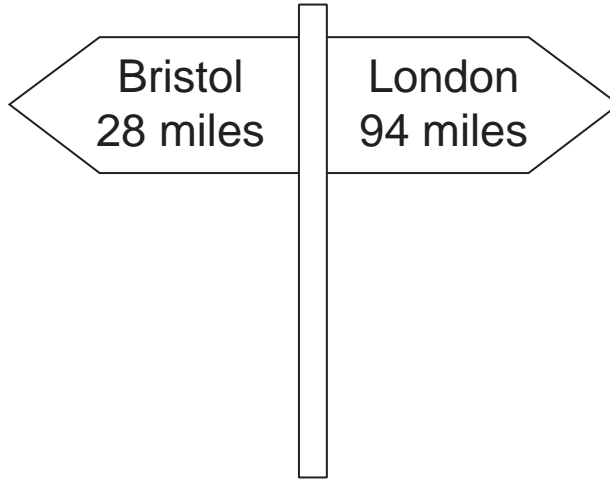
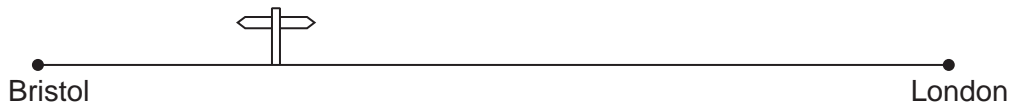

3 (a) Use the sign to work out the distance from Bristol to London.

.....

Answer ..... miles (2 marks)

3 (b) How much further is it to London than to Bristol from the sign?  
Give your answer to the nearest 10 miles.

.....  
.....

Answer ..... miles (3 marks)



4 (a) Measure the size of the **acute** angle.

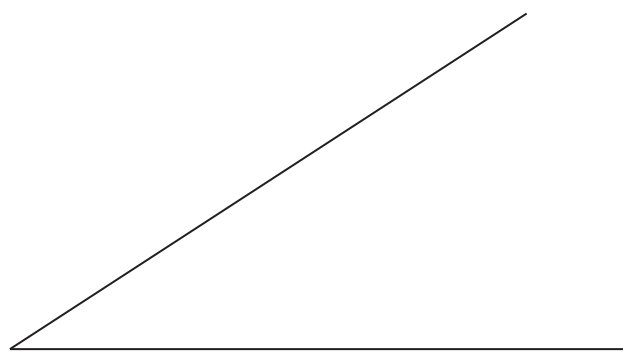

Answer ..... degrees (1 mark)

4 (b) Measure the size of the **obtuse** angle.

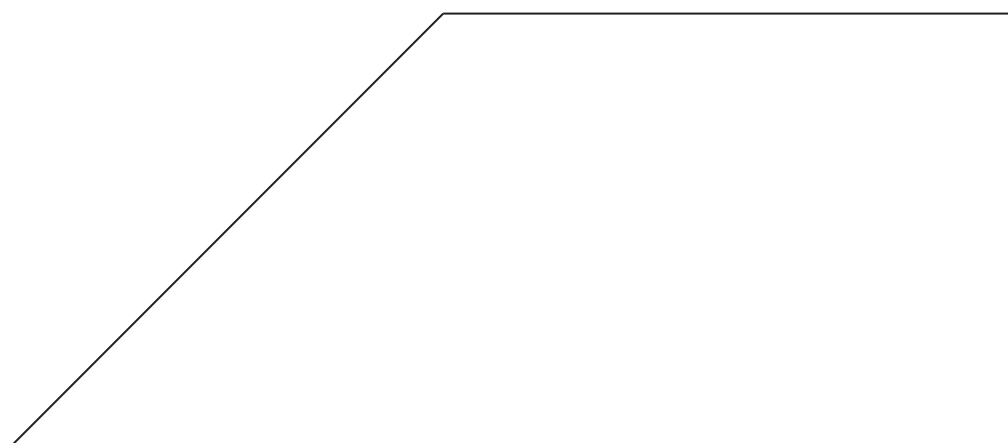

Answer ..... degrees (1 mark)



5 A banana is weighed.

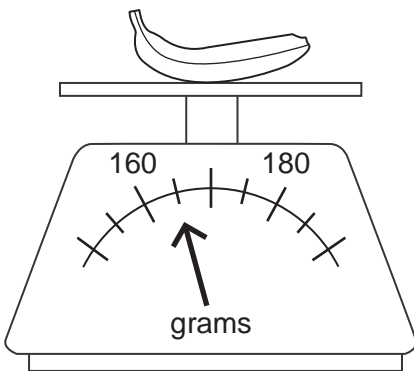

5 (a) How much does the banana weigh?

Answer ..... grams (1 mark)

5 (b) The banana is now weighed with an orange.

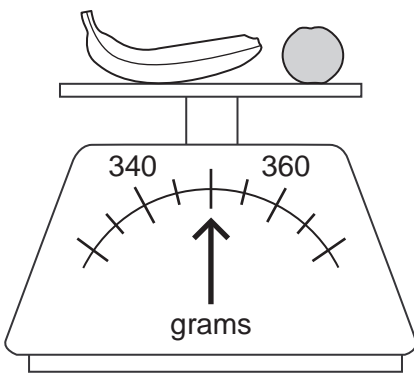

How much does the orange weigh?

.....

.....

Answer ..... grams (2 marks)

5

Turn over ►



**6 (a)** Draw **all** the lines of symmetry on this rectangle.



(2 marks)

**6 (b)** Draw a shape that has exactly

four sides

**and**

one line of symmetry.

(1 mark)





7 (a) This cuboid is made from centimetre cubes.

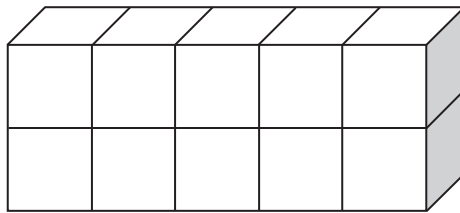

Write down the volume of the cuboid.  
State the units of your answer.

Answer ..... (2 marks)

7 (b) Here is a cuboid measuring 5 cm by 2 cm by 2 cm.

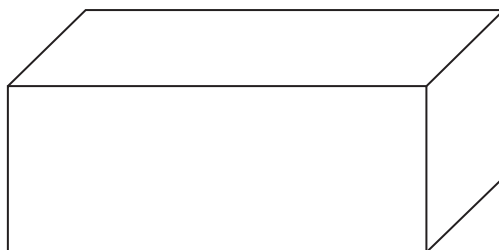

How many centimetre cubes are needed to make this cuboid?

.....

Answer ..... (2 marks)



**8 (a)** The diagram shows a square.

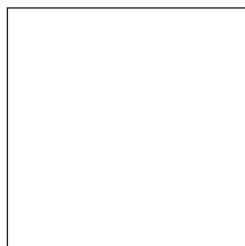

$(x - 3)$  cm

Not drawn  
accurately

How do you know that  $x$  is greater than 3?

.....  
.....

(1 mark)

**8 (b)** Here is a different square.

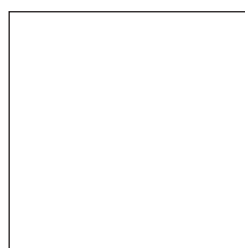

$(y + 4)$  cm

Not drawn  
accurately

The area is  $81 \text{ cm}^2$ .

Work out the value of  $y$ .

.....  
.....

$y =$  .....

(2 marks)



- 9 Here is a centimetre grid with point  $P$  plotted.

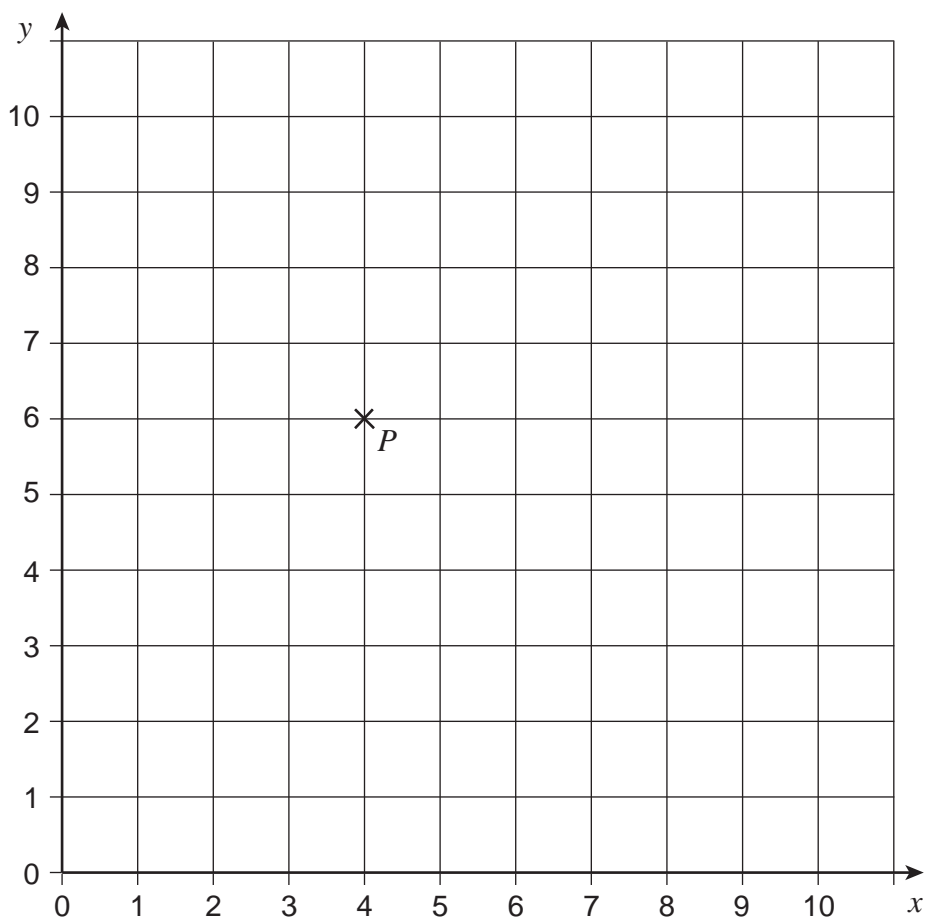

A circle has centre  $P$  and radius 4 cm.  
The circle passes through the points  $A$ ,  $B$ ,  $C$  and  $D$ .

Complete the coordinates for  $A$ ,  $B$ ,  $C$  and  $D$ .

$A$  ( ..... , 2)

$B$  ( 8 , ..... )

$C$  ( ..... , 10)

$D$  ( 0 , ..... )

(4 marks)



10 *ABC* is a straight line.

Not drawn accurately

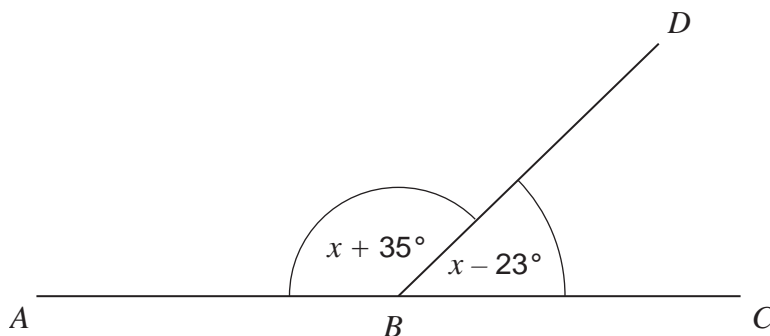

10 (a) How much bigger is angle *ABD* than angle *CBD*?

.....

.....

Answer ..... degrees (2 marks)

\*10 (b) Set up and solve an equation to work out the size of angle *ABD*.

.....

.....

.....

.....

.....

.....

Answer ..... degrees (4 marks)



**11 (a)** How many litres are equivalent to 1 gallon?

Circle your answer.

2.2

2.5

4.5

5

8

(1 mark)

**11 (b)** 1 mile = 1760 yards

Convert 12 056 yards to miles.

Give your answer to the nearest mile.

.....

.....

Answer ..... miles (3 marks)

**12** The scale on a map is 1 : 500 000

Two towns are 8 cm apart on the map.

Work out the actual distance between the towns.

Give your answer in kilometres.

.....

.....

.....

.....

Answer ..... km (3 marks)



13 (a) In the diagram,  $AB = AC$

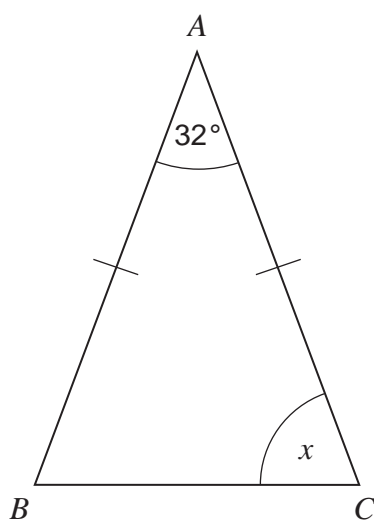

Not drawn  
accurately

Work out the size of angle  $x$ .

.....  
.....

Answer ..... degrees (2 marks)



13 (b) A rhombus is reflected as shown.  
DE is a straight line.

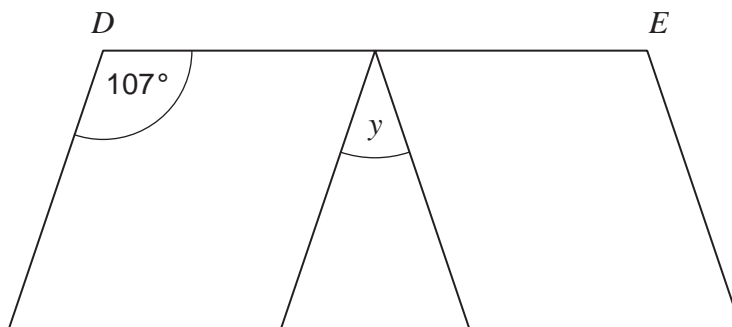

Not drawn accurately

Work out the size of angle  $y$ .  
Show your working, which may be on the diagram.

.....

.....

.....

.....

.....

.....

Answer ..... degrees (3 marks)

Turn over for the next question

5
---

Turn over ►



14 Make an accurate drawing of this cuboid on the isometric grid. One edge has been drawn for you.

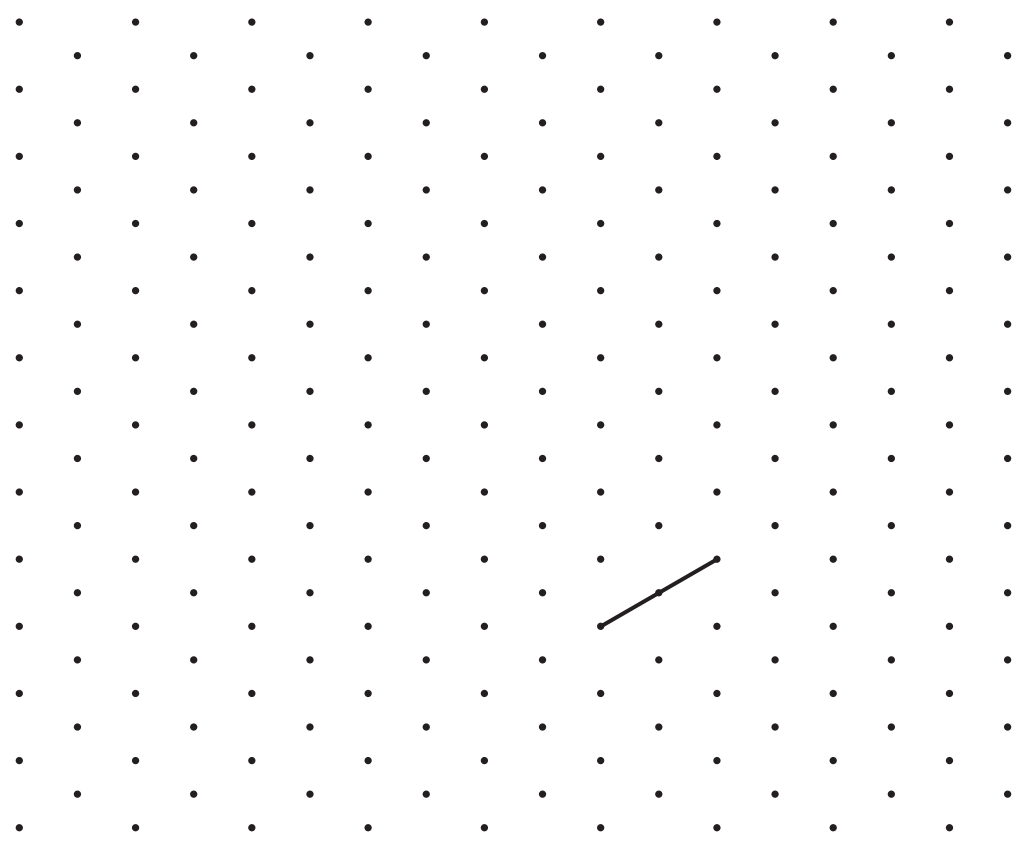
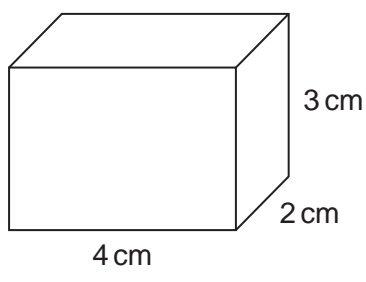

(2 marks)





\*15

Lengths of wood for door frames are 2100 mm each.  
The lengths are sold in packs of 5.

Each door frame needs three pieces, as shown below.

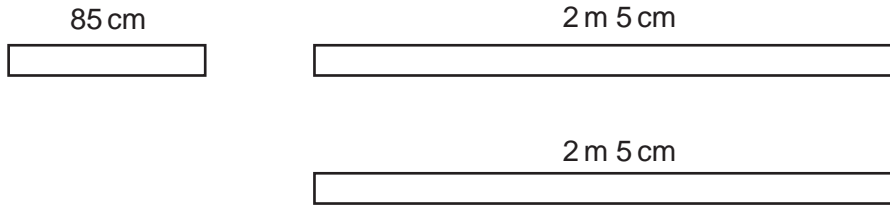

Not drawn accurately

Jon wants to cut pieces of wood to make seven door frames.

How many packs does he need to buy?  
You **must** show how you worked out your answer.

.....

.....

.....

.....

.....

.....

.....

.....

.....

Answer ..... (4 marks)

6

Turn over ►



**16 (a)** On the grid, draw a  $90^\circ$  clockwise rotation of shape *A*.  
Label it *B*.

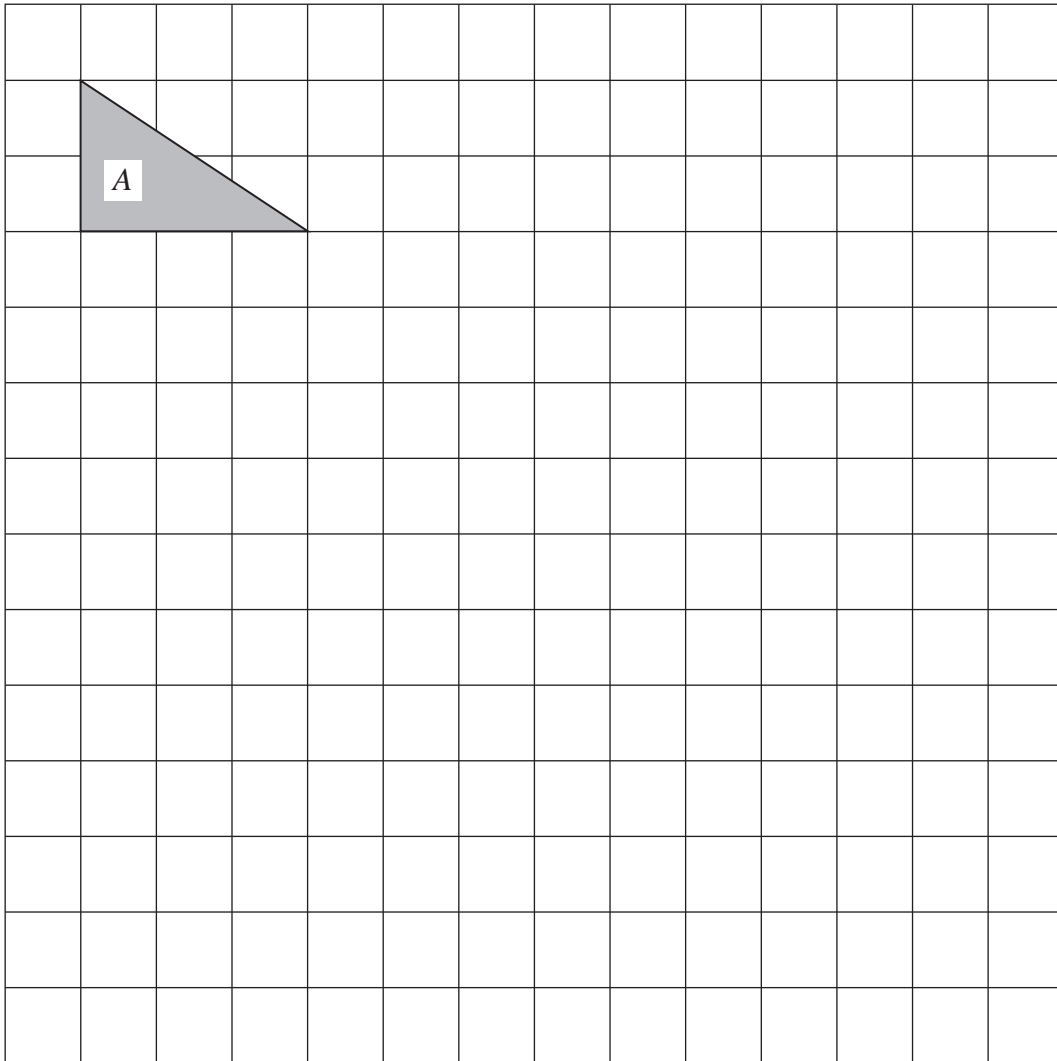

(2 marks)



**16 (b)** On this grid, draw an enlargement of shape *A* by scale factor 3.  
Label it *C*.

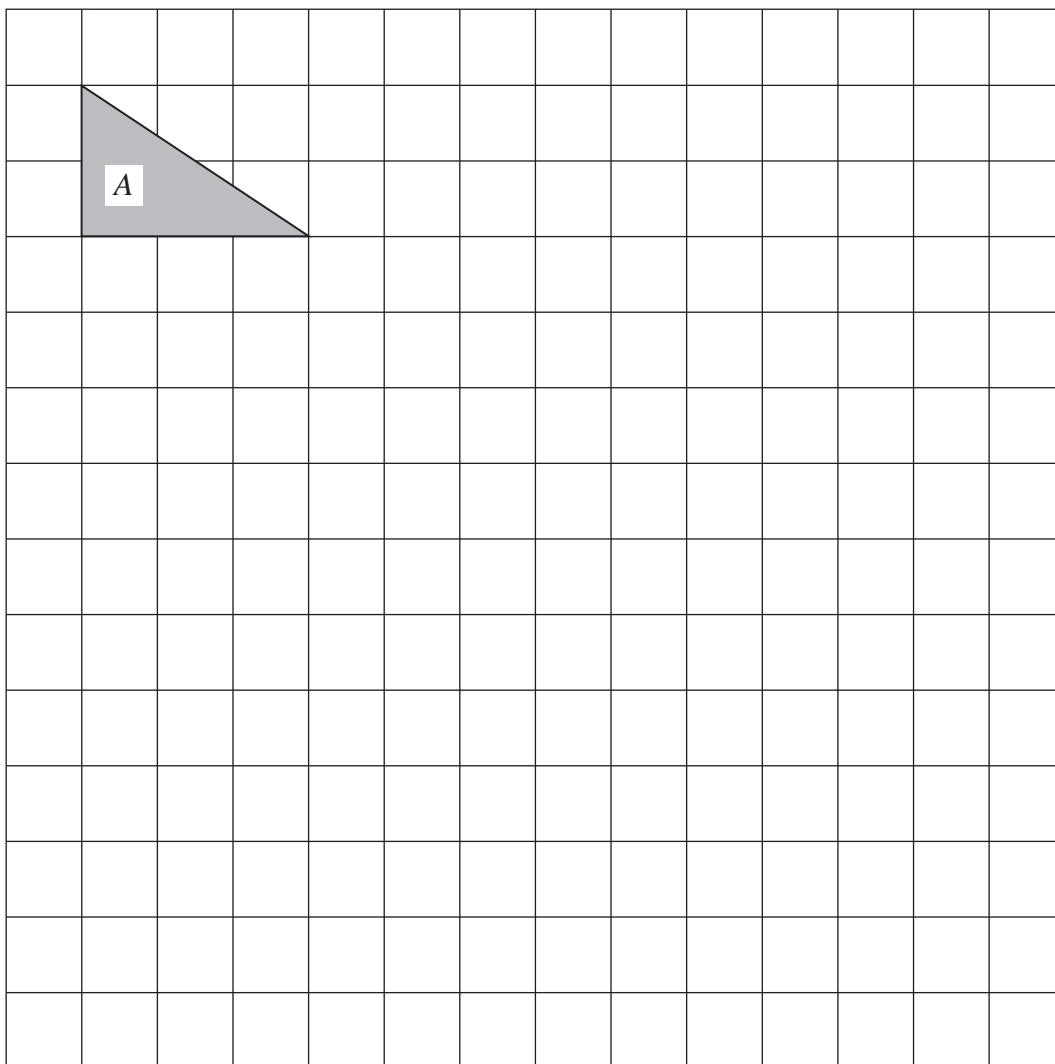

(2 marks)

**16 (c)** Work out the area of shape *C*.

.....  
.....

Answer ..... cm<sup>2</sup> (2 marks)

6

Turn over ►



17 (a) Complete the table of values for  $y = x^2$

$x$	-2	-1	0	1	2
$y$	4			1	

(2 marks)

17 (b) On the grid, draw the graph of  $y = x^2$  for values of  $x$  from -2 to 2.

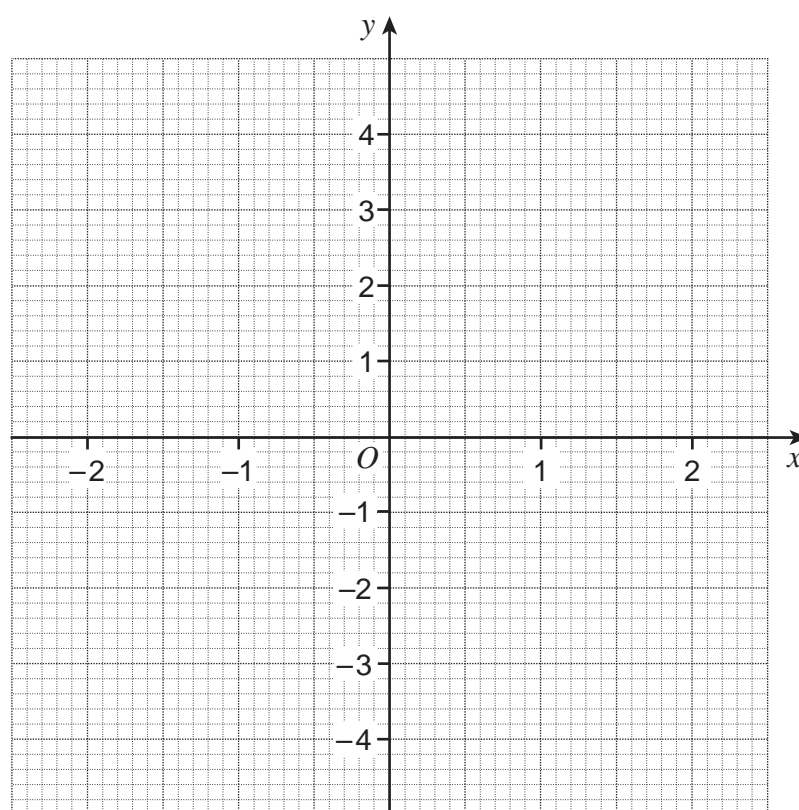

(2 marks)



18 This shape is made from identical quarter circles.

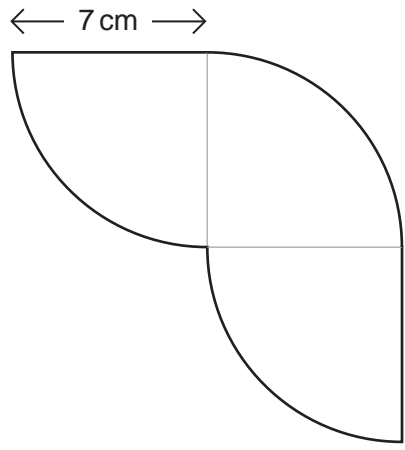

Not drawn  
accurately

Work out the perimeter of the shape.

.....

.....

.....

.....

.....

.....

Answer ..... cm (4 marks)



19 Work out the length  $x$ .

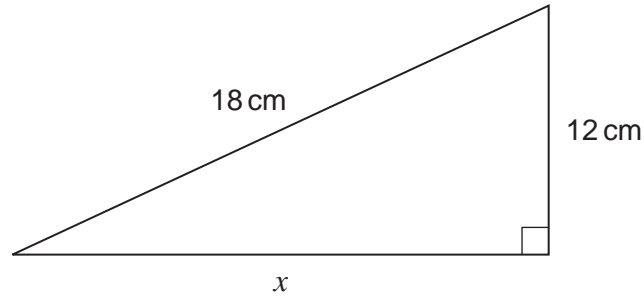

Not drawn  
accurately

Give your answer to 1 decimal place.

.....

.....

.....

.....

Answer ..... cm (4 marks)



20 Use a calculator to work out the area of the rectangle.

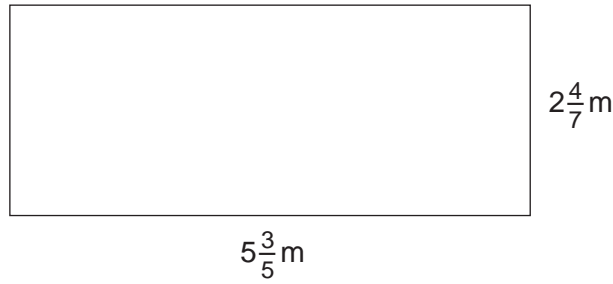

Not drawn  
accurately

Give your answer as a mixed fraction.

.....  
.....  
.....

Answer .....  $\text{m}^2$  (2 marks)

Turn over for the next question



21 The diagram shows two cylinders.

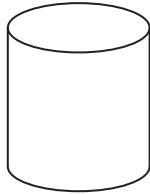

radius 4 cm
height 9 cm

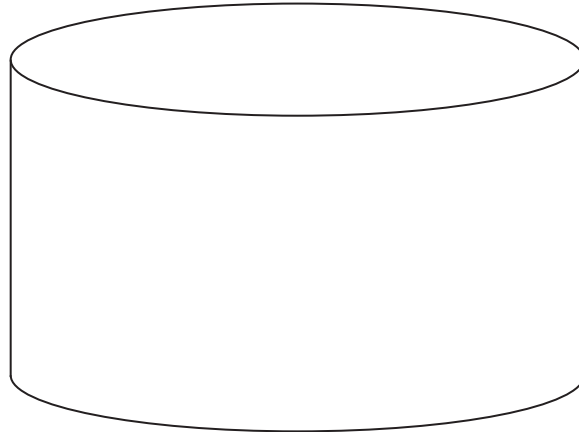

radius 10 cm
height 36 cm

How many times bigger is the volume of the large cylinder than the small cylinder?  
You **must** show your working.

.....

.....

.....

.....

.....

.....

Answer ..... (4 marks)

**END OF QUESTIONS**

