



**Cambridge International Examinations**  
Cambridge International General Certificate of Secondary Education

CANDIDATE  
NAME

CENTRE  
NUMBER

--	--	--	--	--	--

CANDIDATE  
NUMBER

--	--	--	--

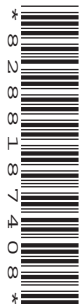

**MATHEMATICS**

**0580/32**

Paper 3 (Core)

**May/June 2018**

**2 hours**

Candidates answer on the Question Paper.

Additional Materials:      Electronic calculator  
   Tracing paper (optional)

Geometrical instruments

**READ THESE INSTRUCTIONS FIRST**

Write your Centre number, candidate number and name on all the work you hand in.

Write in dark blue or black pen.

You may use an HB pencil for any diagrams or graphs.

Do not use staples, paper clips, glue or correction fluid.

**DO NOT WRITE IN ANY BARCODES.**

Answer **all** questions.

If working is needed for any question it must be shown below that question.

Electronic calculators should be used.

If the degree of accuracy is not specified in the question, and if the answer is not exact, give the answer to three significant figures. Give answers in degrees to one decimal place.

For  $\pi$ , use either your calculator value or 3.142.

At the end of the examination, fasten all your work securely together.

The number of marks is given in brackets [ ] at the end of each question or part question.

The total of the marks for this paper is 104.

This document consists of **16** printed pages.

1 (a) Find the value of

(i) the square root of 19044,

..... [1]

(ii)  $2^7$ .

..... [1]

(b)  $n$  is an integer and  $120 < n < 140$ .

Find the value of  $n$  when it is

(i) a multiple of 45,

$n =$  ..... [1]

(ii) a square number,

$n =$  ..... [1]

(iii) a factor of 402,

$n =$  ..... [1]

(iv) a cube number.

$n =$  ..... [1]

(c) Work out the value of  $\frac{21 - 15 \times 3}{18 \div 6 - 4}$ .

..... [2]

(d) Estimate the value of  $\frac{19.2 \times \sqrt{8.64}}{31.6 \div 6.32}$  by rounding each number in the calculation to 1 significant figure.

Show all your working by filling in the calculation below.

$$\frac{\dots \times \sqrt{\dots}}{\dots \div \dots} = \dots [2]$$

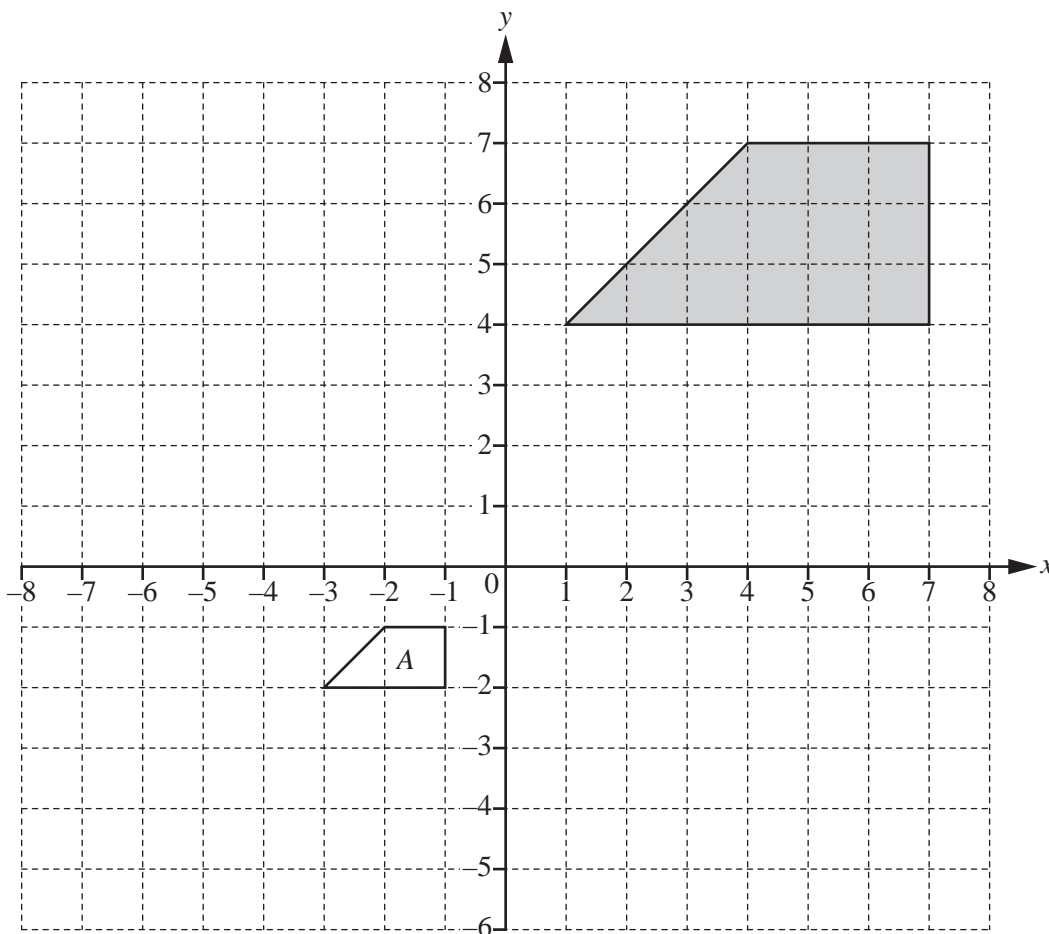

(a) Write down the mathematical name of the shaded quadrilateral shown on the grid.  
 ..... [1]

(b) Describe fully the **single** transformation that maps the shaded quadrilateral onto quadrilateral A.  
 .....  
 ..... [3]

(c) Complete this statement with a fraction in its simplest form.

The area of quadrilateral A is ..... of the area of the shaded quadrilateral. [3]

- (d) On the grid, draw the image of
- (i) shape A after a translation by the vector  $\begin{pmatrix} -4 \\ 7 \end{pmatrix}$ , [2]
  - (ii) shape A after a rotation of  $180^\circ$  about the origin, [2]
  - (iii) shape A after a reflection in the line  $x = 2$ . [2]

3 A car company has three sales people, Anna, Mustapha and Joshua.

(a) During March, Anna sold 21 cars, Mustapha sold 12 cars and Joshua sold 15 cars.

Write down and simplify the ratio of the number of cars they sold during March.

Anna : Mustapha : Joshua = ..... : ..... : ..... [2]

(b) Each month, they receive a bonus which is proportional to the number of cars they sell.  
The total bonus in March is \$1248.

(i) Show that Anna receives a bonus of \$546.

[1]

(ii) Calculate the bonuses received by Mustapha and Joshua.

Mustapha \$ .....

Joshua \$ ..... [2]

(c) The total bonus of \$1248 is  $\frac{3}{7}$  of the total profit in March.

Calculate the total profit in March.

\$ ..... [2]

5

- (d) Ella wants to buy a car with a price of \$13 500.  
The company reduces this price by 16%.  
Ella then pays a deposit of \$500.

Show that the amount left for her to pay is \$10 840.

[2]

- (e) Ella borrows \$10 840 from a bank.  
She pays this back over 3 years at a rate of \$340 per month.

- (i) Show that the total amount she pays back during the 3 years is \$12 240.

[1]

- (ii) Calculate the percentage increase from \$10 840 to \$12 240.

.....% [3]

6

- 4 (a) Complete the table of values for  $y = 5x - x^2$ .

$x$	-1	0	1	2	3	4	5	6
$y$		0		6	6			-6

[2]

- (b) On the grid, draw the graph of  $y = 5x - x^2$  for  $-1 \leq x \leq 6$ .

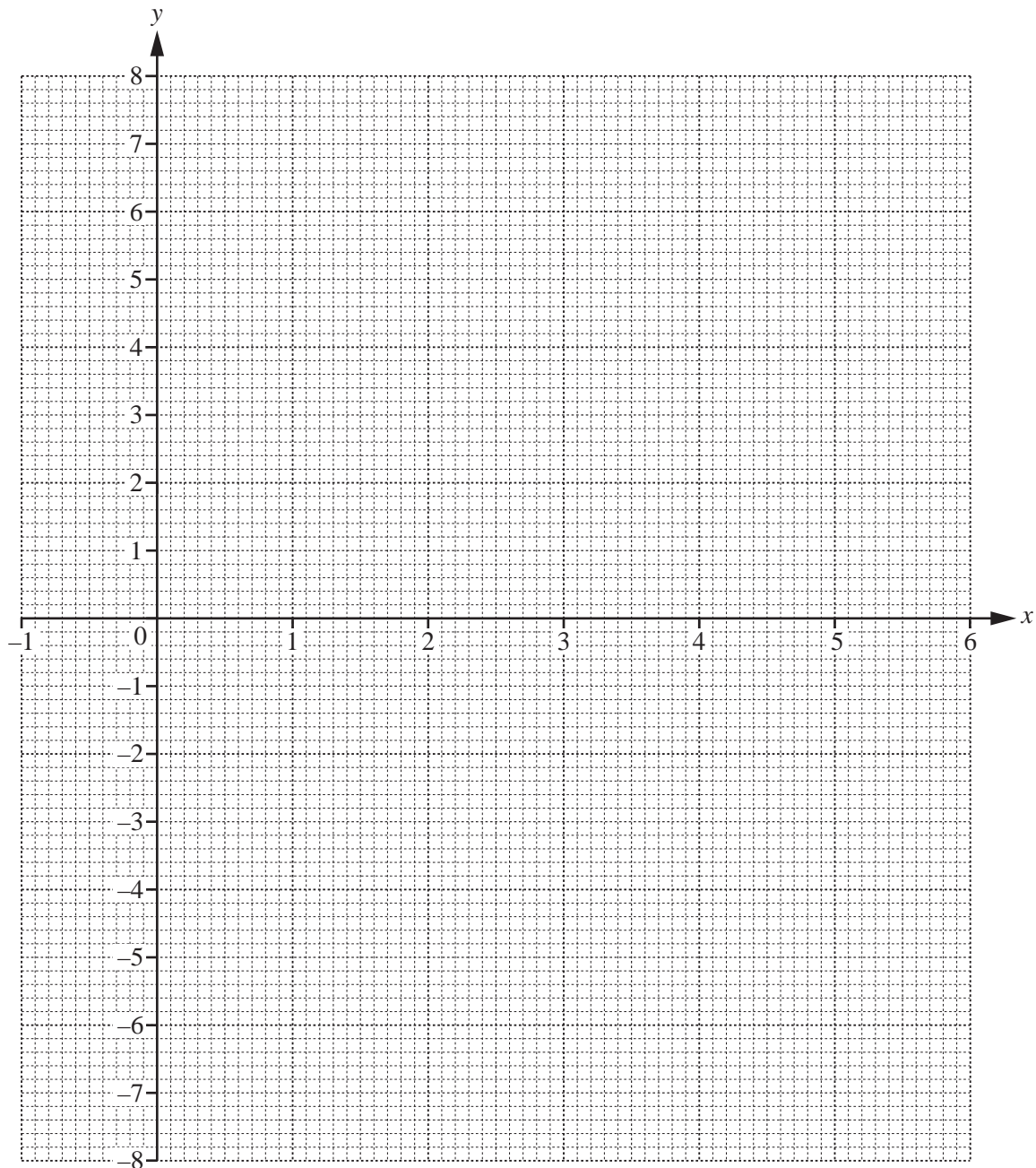

[4]

(c) Write down the equation of the line of symmetry of the graph.

..... [1]

(d) (i) Complete the table of values for  $y = 1.5x - 2$ .

$x$	0	2	5
$y$			

[2]

(ii) On the grid, draw the graph of  $y = 1.5x - 2$  for  $-1 \leq x \leq 6$ .

[2]

(iii) Use your graphs to write down the solutions to the equation  $1.5x - 2 = 5x - x^2$ .

$x = \dots\dots\dots$  or  $x = \dots\dots\dots$  [2]

- 5 The scale drawing represents three sides,  $AB$ ,  $BC$  and  $CD$ , of a wildlife park. The scale is 1 centimetre represents 50 metres.

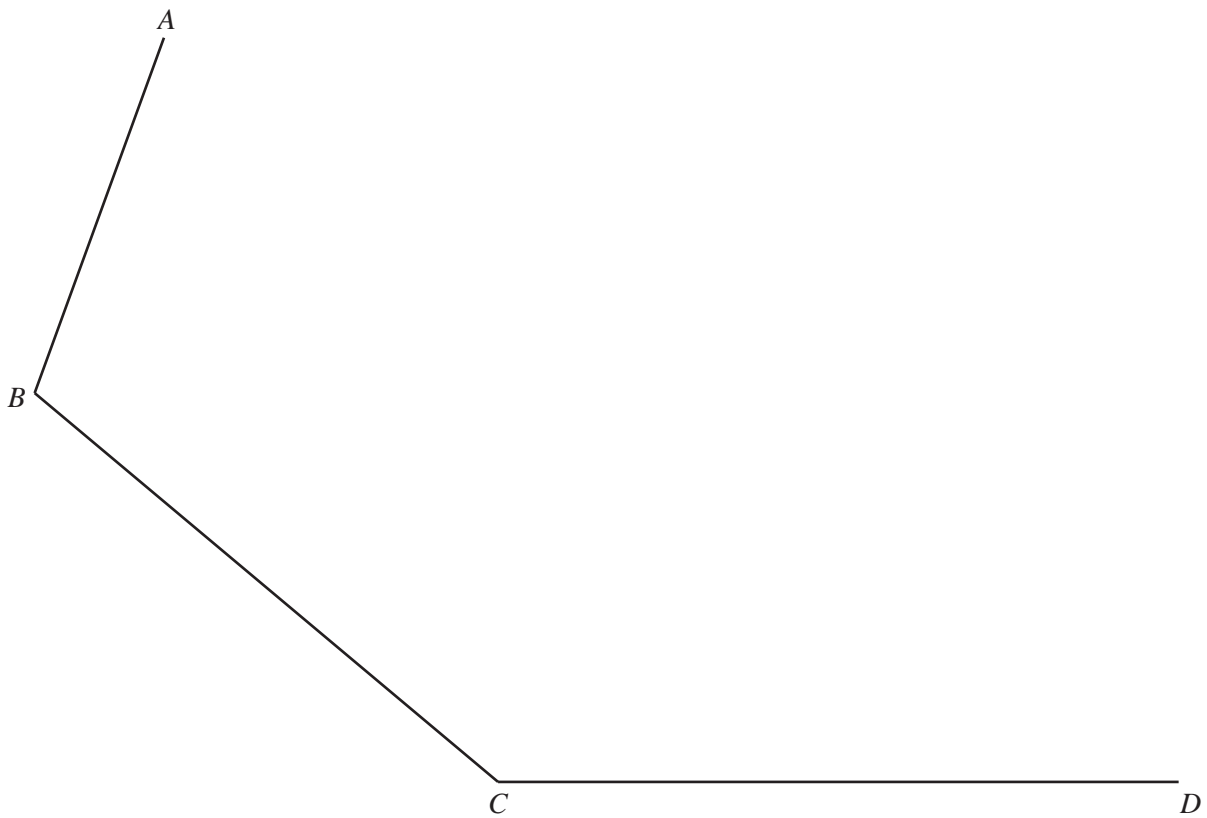

Scale: 1 cm to 50 m



- (a) Find the actual distance  $AB$  in metres.

..... m [2]

- (b) Point  $E$  is 550 metres from  $A$  and 600 metres from  $D$ .

**Use a ruler and compasses only** to find the point  $E$  and draw the lines  $AE$  and  $DE$ . [3]

- (c) Two straight paths cross the wildlife park,  $ABCDE$ .

**Using a straight edge and compasses only**, construct

- (i) the path that bisects angle  $ABC$ , [2]

- (ii) the path that is equidistant from point  $C$  and point  $D$ . [2]

- (d) The path from  $B$  crosses over a circular lake with radius 150 m.  
The centre of the lake is on this path and is 350 m from  $B$ .

- (i) On the scale drawing, construct the lake. [3]

- (ii) Calculate the actual circumference of the lake in metres.

..... m [2]

- 6 The 262 students at a college each study one of the languages shown in the table.

	French	German	Spanish	Italian	Japanese	Total
Boys	27		48	19		123
Girls		32	54		12	
Total		53		30		262

- (a) Complete the table. [3]

- (b) Find the probability that

- (i) a girl, chosen at random, studies Spanish,

..... [1]

- (ii) a boy, chosen at random, studies French or Italian,

..... [1]

- (iii) a student, chosen at random, does not study German.

..... [1]

- (c) 72 students each study one of the sciences shown in the table.  
The results are to be shown in a pie chart.

Science	Number of students	Pie chart sector angle
Biology	25	125°
Chemistry	16	
Physics	31	

(i) Complete the table.

[2]

(ii) Complete the pie chart.

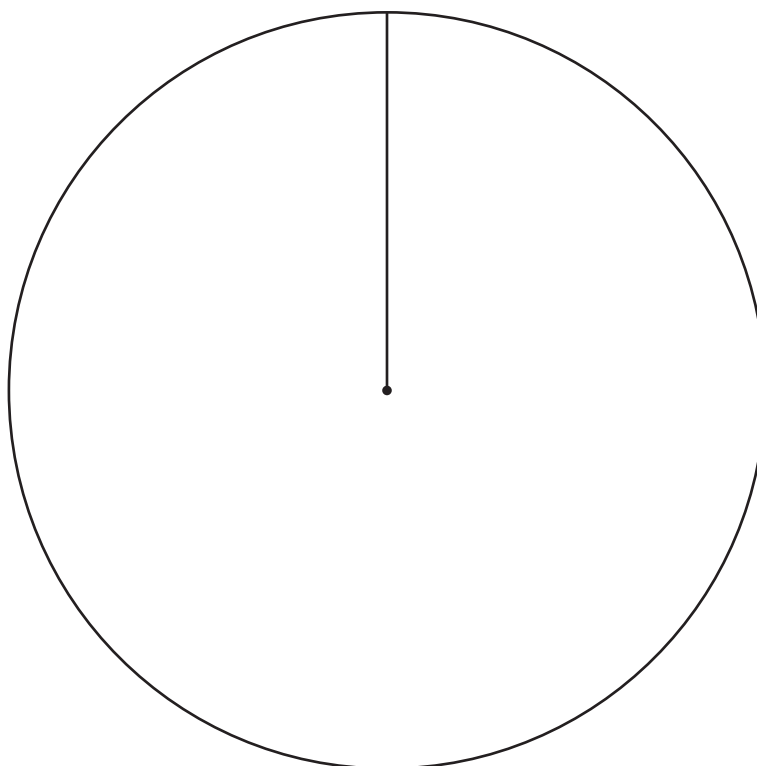

[2]

- 7 Louise leaves home at 09 55 and cycles the 5.6 km to the supermarket at a constant speed. She takes 15 minutes to complete the journey.

(a) Write down the time she arrives at the supermarket.

..... [1]

(b) Calculate Louise's average speed from her home to the supermarket

(i) in kilometres per hour,

..... km/h [1]

(ii) in metres per second, giving your answer correct to 1 decimal place.

..... m/s [2]

(c) Louise stays at the supermarket for 23 minutes.

On the grid opposite, draw the travel graph of her journey from home and her stay at the supermarket. [2]

(d) Louise's mother leaves home at 10 07 to meet Louise at the supermarket. She cycles at a constant speed of 28 km/h.

(i) Work out how long she takes for the 5.6 km journey. Give your answer in minutes.

..... min [2]

(ii) On the grid, show her mother's journey. [1]

(e) They cycle home together at a constant speed and arrive at 10 54.

(i) On the grid, show their journey home. [1]

(ii) Calculate, in km/h, their constant speed on the journey home.

..... km/h [2]

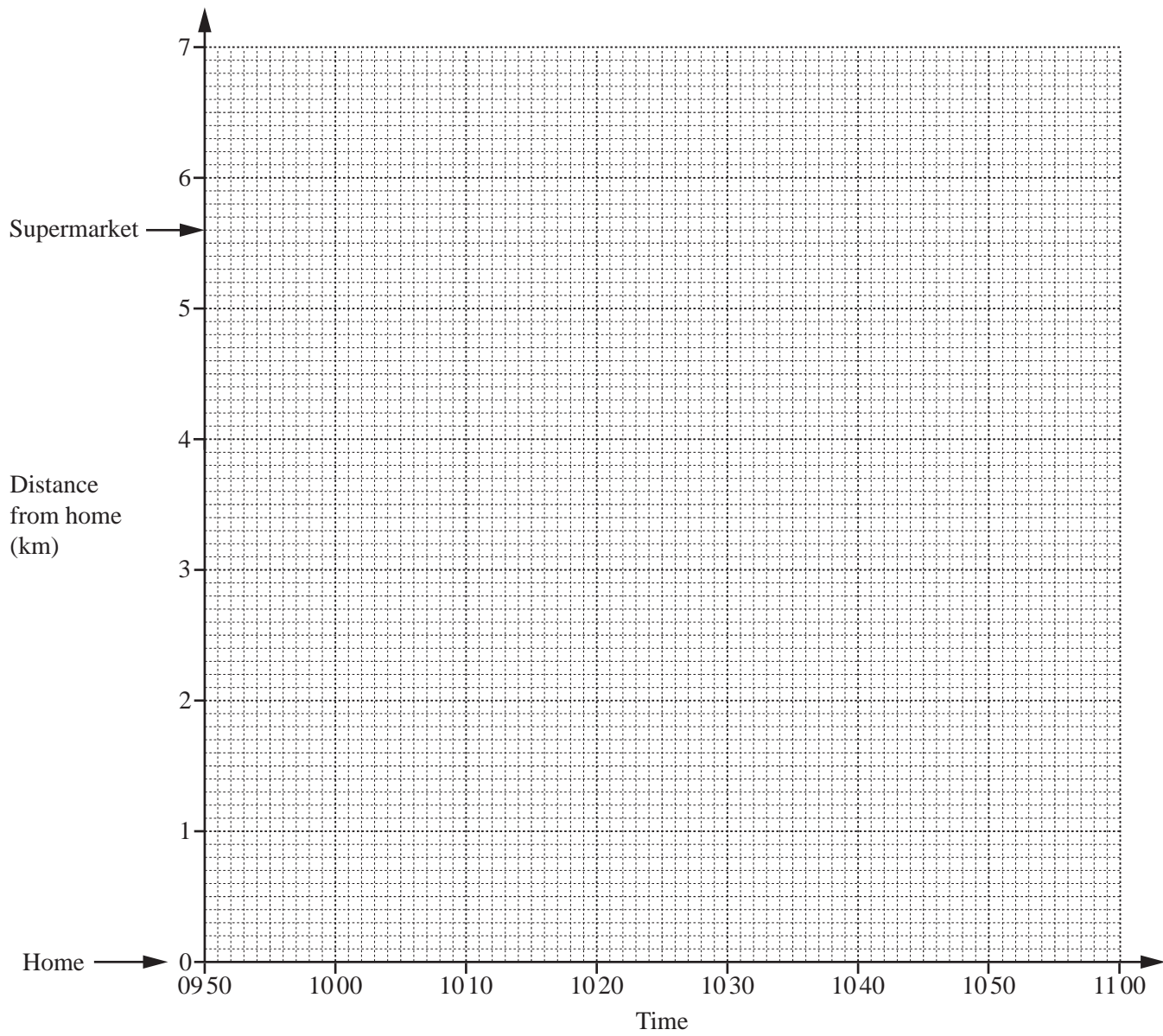

8 (a)

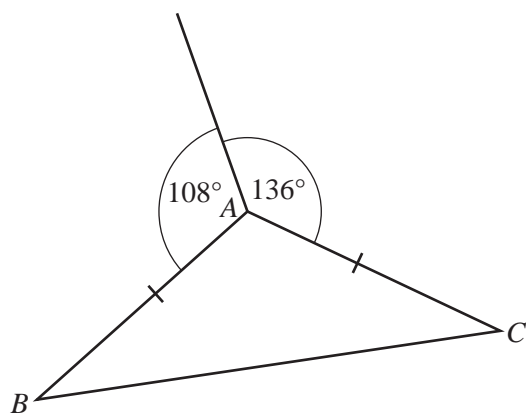
NOT TO  
SCALE

In the diagram,  $AB = AC$ .

Find

(i) angle  $BAC$ ,

Angle  $BAC = \dots\dots\dots$  [1]

(ii) angle  $ABC$ .

Angle  $ABC = \dots\dots\dots$  [1]

(b)

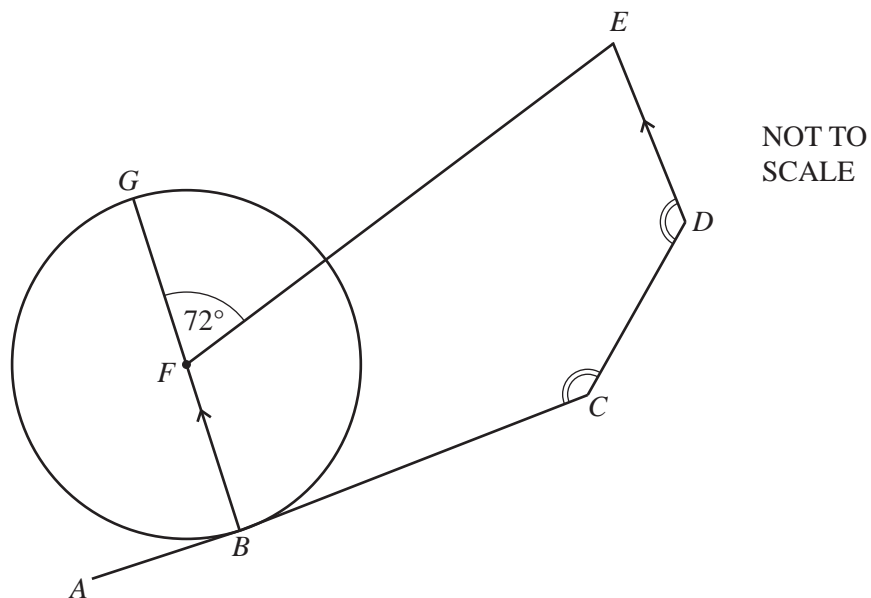

The diagram shows a circle, centre  $F$  and diameter  $BG$ .  
 $AC$  is a tangent to the circle at  $B$ .  
 $BF$  is parallel to  $DE$ , angle  $GFE = 72^\circ$  and angle  $BCD = \text{angle } CDE$ .

(i) Write down the mathematical name of the polygon  $BCDEF$ .  
 ..... [1]

(ii) Explain why angle  $FBC$  is a right angle.  
 ..... [1]

(iii) Find angle  $BFE$ , giving a reason for your answer.  
 Angle  $BFE = \dots\dots\dots$  because .....  
 ..... [2]

(iv) Find angle  $FED$ .  
 Angle  $FED = \dots\dots\dots$  [1]

(v) Calculate angle  $BCD$ .  
 Angle  $BCD = \dots\dots\dots$  [4]

Question 9 is printed on the next page.

- 9 (a) Solve the equation  $3(2x - 4) = 4(x + 7)$ .

$$x = \dots\dots\dots [3]$$

- (b) Beindu goes to the market to buy apples and bananas.  
She can buy

- 7 apples and 4 bananas for 85 cents
- or
- 3 apples and 8 bananas for 93 cents.

Apples cost  $a$  cents each and bananas cost  $b$  cents each.

- (i) This information can be used to write down two equations.  
One of these is  $7a + 4b = 85$ .

Write down the other equation.

$$\dots\dots\dots = \dots\dots\dots [2]$$

- (ii) Solve these two simultaneous equations.  
You must show all your working.

$$a = \dots\dots\dots$$

$$b = \dots\dots\dots [3]$$

---

Permission to reproduce items where third-party owned material protected by copyright is included has been sought and cleared where possible. Every reasonable effort has been made by the publisher (UCLES) to trace copyright holders, but if any items requiring clearance have unwittingly been included, the publisher will be pleased to make amends at the earliest possible opportunity.

To avoid the issue of disclosure of answer-related information to candidates, all copyright acknowledgements are reproduced online in the Cambridge International Examinations Copyright Acknowledgements Booklet. This is produced for each series of examinations and is freely available to download at [www.cie.org.uk](http://www.cie.org.uk) after the live examination series.

Cambridge International Examinations is part of the Cambridge Assessment Group. Cambridge Assessment is the brand name of University of Cambridge Local Examinations Syndicate (UCLES), which is itself a department of the University of Cambridge.