

Write your name here

Surname

Other names

**Pearson Edexcel  
International GCSE**

Centre Number

--	--	--	--	--

Candidate Number

--	--	--	--

# Mathematics A

**Level 1/2  
Paper 1HR**



**Higher Tier**

Thursday 24 May 2018 – Morning

**Time: 2 hours**

Paper Reference

**4MA1/1HR**

**You must have:**

Ruler graduated in centimetres and millimetres, protractor, compasses, pen, HB pencil, eraser, calculator. Tracing paper may be used.

Total Marks

## Instructions

- Use **black** ink or ball-point pen.
- **Fill in the boxes** at the top of this page with your name, centre number and candidate number.
- Answer **all** questions.
- Without sufficient working, correct answers may be awarded no marks.
- Answer the questions in the spaces provided  
– *there may be more space than you need.*
- **Calculators may be used.**
- You must **NOT** write anything on the formulae page.  
Anything you write on the formulae page will gain NO credit.

## Information

- The total mark for this paper is 100.
- The marks for **each** question are shown in brackets  
– *use this as a guide as to how much time to spend on each question.*

## Advice

- Read each question carefully before you start to answer it.
- Check your answers if you have time at the end.

Turn over ►

P59012A

©2018 Pearson Education Ltd.

1/1/1/



Pearson

## International GCSE Mathematics

## Formulae sheet – Higher Tier

**Arithmetic series**

Sum to  $n$  terms,  $S_n = \frac{n}{2} [2a + (n-1)d]$

**The quadratic equation**

The solutions of  $ax^2 + bx + c = 0$  where  $a \neq 0$  are given by:

$$x = \frac{-b \pm \sqrt{b^2 - 4ac}}{2a}$$

**Area of trapezium** =  $\frac{1}{2}(a + b)h$

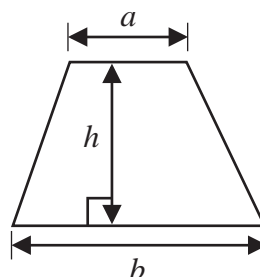
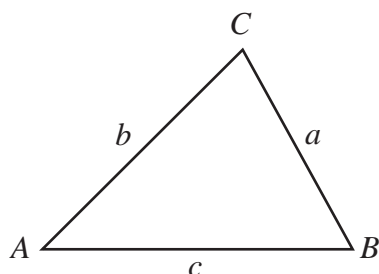
**Trigonometry**

**In any triangle ABC**

**Sine Rule**  $\frac{a}{\sin A} = \frac{b}{\sin B} = \frac{c}{\sin C}$

**Cosine Rule**  $a^2 = b^2 + c^2 - 2bc \cos A$

**Area of triangle** =  $\frac{1}{2}ab \sin C$

**Volume of cone** =  $\frac{1}{3}\pi r^2 h$

**Curved surface area of cone** =  $\pi r l$

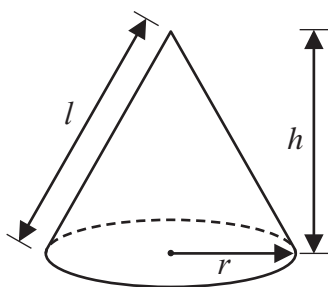

**Volume of prism**

= area of cross section  $\times$  length

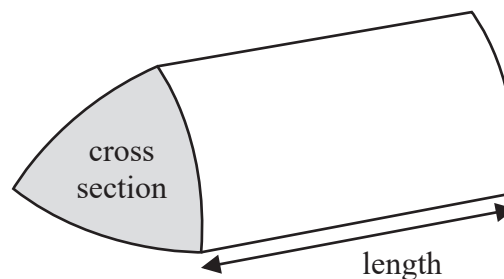

**Volume of cylinder** =  $\pi r^2 h$

**Curved surface area of cylinder** =  $2\pi r h$

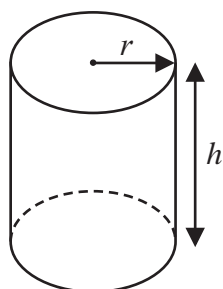

**Volume of sphere** =  $\frac{4}{3}\pi r^3$

**Surface area of sphere** =  $4\pi r^2$

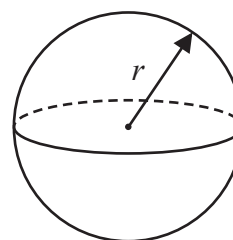

DO NOT WRITE IN THIS AREA

DO NOT WRITE IN THIS AREA

DO NOT WRITE IN THIS AREA



DO NOT WRITE IN THIS AREA

DO NOT WRITE IN THIS AREA

DO NOT WRITE IN THIS AREA

Answer ALL TWENTY THREE questions.

Write your answers in the spaces provided.

You must write down all the stages in your working.

1 Here is a hexagon  $ABCDEF$ .

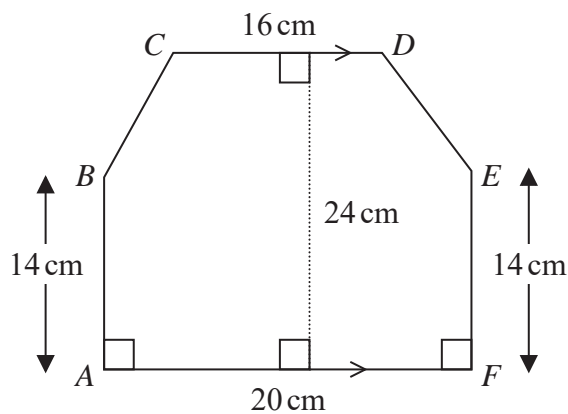

Diagram NOT accurately drawn

$CD$  is parallel to  $AF$ .

Work out the area of hexagon  $ABCDEF$ .

.....  $\text{cm}^2$

(Total for Question 1 is 4 marks)



- 2 The table gives information about the times, in hours, some students spent doing sport one week.

Time ( $T$ hours)	Frequency
$0 < T \leq 2$	5
$2 < T \leq 4$	9
$4 < T \leq 6$	24
$6 < T \leq 8$	40
$8 < T \leq 10$	7

Calculate an estimate for the mean time these students spent doing sport.  
Give your answer in hours, correct to 1 decimal place.

..... hours

**(Total for Question 2 is 4 marks)**

DO NOT WRITE IN THIS AREA

DO NOT WRITE IN THIS AREA

DO NOT WRITE IN THIS AREA



3

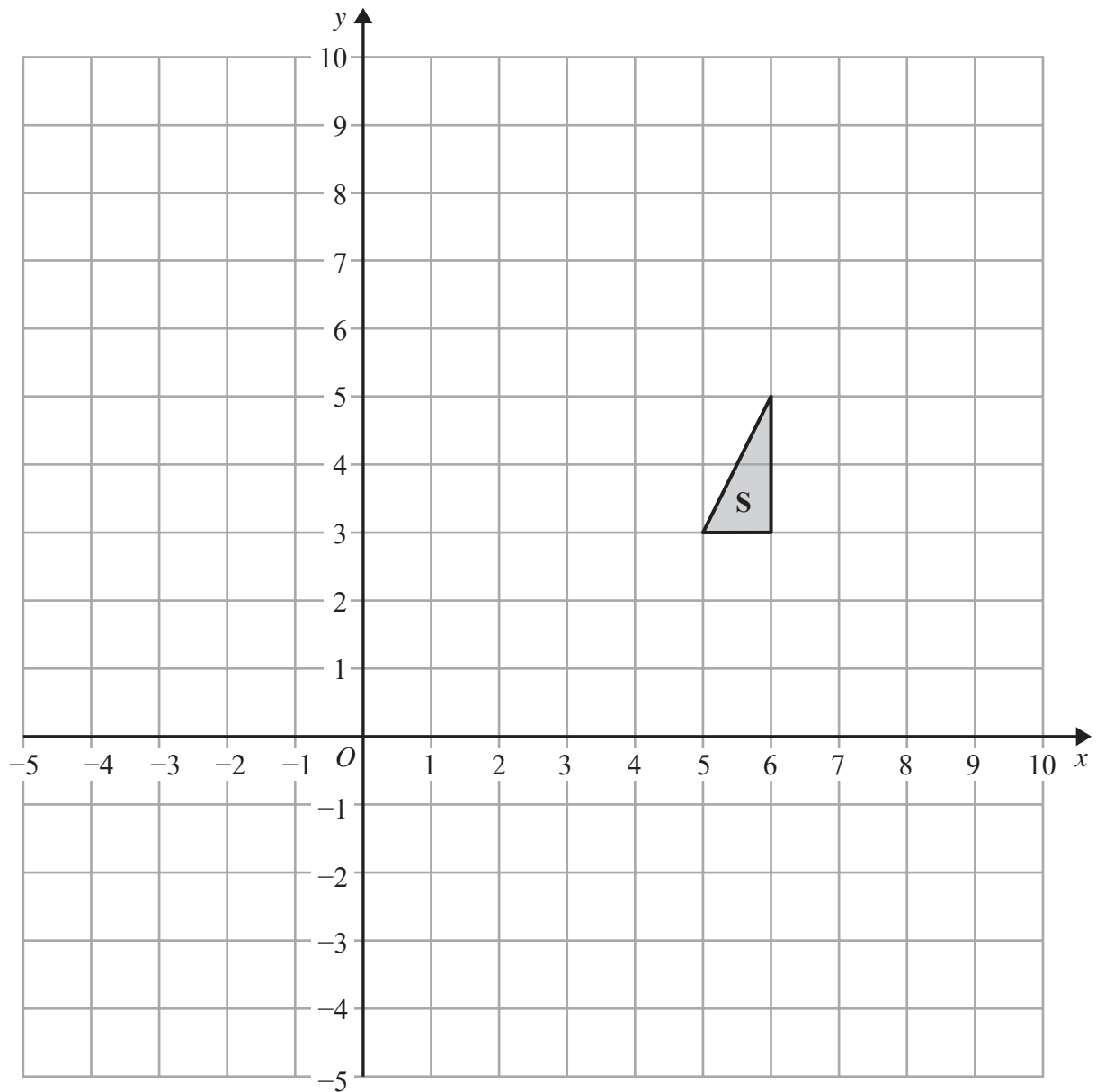

- (a) Reflect triangle **S** in the line  $y = x$   
Label the new triangle **R**. (2)
- (b) Translate triangle **S** by the vector  $\begin{pmatrix} -4 \\ -6 \end{pmatrix}$   
Label the new triangle **T**. (1)

(Total for Question 3 is 3 marks)



P 5 9 0 1 2 A 0 5 2 4

- 4 Anna and Lionel share \$675 in the ratio 4 : 5

Lionel gives  $\frac{3}{5}$  of his share of the money to his mother.

How much money does Lionel give to his mother?

\$.....

**(Total for Question 4 is 3 marks)**

- 5  $E = n^2 + n + 5$

Ali thinks that the value of  $E$  will be a prime number for any whole number value of  $n$ .

Is Ali correct?

You must give a reason for your answer.

**(Total for Question 5 is 2 marks)**

DO NOT WRITE IN THIS AREA

DO NOT WRITE IN THIS AREA

DO NOT WRITE IN THIS AREA



6

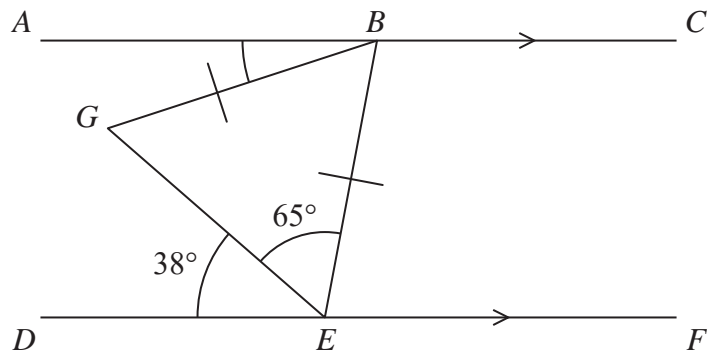

Diagram **NOT**  
accurately drawn

$ABC$  and  $DEF$  are parallel lines.

$BG = BE$

Angle  $DEG = 38^\circ$

Angle  $GEB = 65^\circ$

Find the size of angle  $ABG$ .

(Total for Question 6 is 3 marks)



7 Here are the first four terms of an arithmetic sequence.

6      10      14      18

(a) Find an expression, in terms of  $n$ , for the  $n$ th term of this sequence.

.....  
(2)

(b) Write down an expression, in terms of  $n$ , for the  $(n + 1)$ th term of this sequence.

.....  
(1)

**(Total for Question 7 is 3 marks)**

8 (a) Write 1 390 000 in standard form.

.....  
(1)

(b) Write 0.005 in standard form.

.....  
(1)

**(Total for Question 8 is 2 marks)**

DO NOT WRITE IN THIS AREA

DO NOT WRITE IN THIS AREA

DO NOT WRITE IN THIS AREA





- 9 Here is an empty pool in the shape of a cuboid.

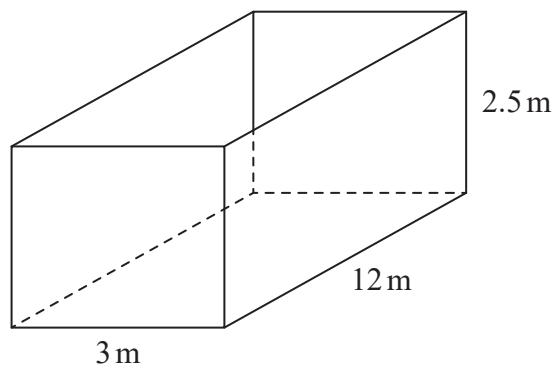

Diagram **NOT**  
accurately drawn

The width of the pool is 3 m.

The length of the pool is 12 m.

The top of the pool is 2.5 m above the base of the pool.

Jeb is going to put water in the pool.

The level of the surface of the water will be 60 cm below the top of the pool.

Water flows into the pool at 400 litres per minute.

$1 \text{ m}^3 = 1000$  litres

How long will it take to fill the pool to 60 cm below the top of the pool?

Give your answer in hours and minutes.

..... hours ..... minutes

**(Total for Question 9 is 4 marks)**



10 Solve

$$\begin{aligned}3x + 2y &= 15 \\10x - 4y &= 2\end{aligned}$$

Show clear algebraic working.

$x = \dots\dots\dots$

$y = \dots\dots\dots$

(Total for Question 10 is 3 marks)

11 Change a speed of 72 kilometres per hour to a speed in metres per second.

..... metres per second

(Total for Question 11 is 3 marks)

DO NOT WRITE IN THIS AREA

DO NOT WRITE IN THIS AREA

DO NOT WRITE IN THIS AREA



DO NOT WRITE IN THIS AREA

DO NOT WRITE IN THIS AREA

DO NOT WRITE IN THIS AREA

12 A company makes cars.

In 2016, the company made 350 cars.

In the first 6 months of 2017, the company made 25 cars each month.

In the last 6 months of 2017, the company made 45 cars each month.

(a) Work out the percentage increase in the number of cars the company made from 2016 to 2017

..... %  
(4)

The company's income in 2017 was \$500 000 more than the company's income in 2016

The company's income in 2017 was 8% more than the company's income in 2016

(b) Work out the company's income in 2016

\$.....  
(3)

(Total for Question 12 is 7 marks)



13 Each month Edna spends all her income on rent, on travel and on other living expenses.

She spends  $\frac{1}{3}$  of her income on rent.

She spends  $\frac{1}{5}$  of her income on travel.

She spends \$420 of her income on other living expenses.

Work out her income each month.

\$.....

(Total for Question 13 is 4 marks)

DO NOT WRITE IN THIS AREA

DO NOT WRITE IN THIS AREA

DO NOT WRITE IN THIS AREA



14 (a) Simplify  $(2e^2 f^3)^3$

.....  
(2)

(b) Expand and simplify  $(3x - 4y)(x + 3y)$

.....  
(2)

$\frac{\sqrt{a} \times a}{a^{-2}}$  can be written in the form  $a^k$

(c) Find the value of  $k$ .

$k =$  .....  
(2)

(d) Simplify  $\frac{2^n - 1}{4^n - 1}$

.....  
(2)

(Total for Question 14 is 8 marks)



15 There are two bags of counters, bag X and bag Y.

There are 20 counters in bag X.  
11 of the counters are blue and the rest are red.

There are 16 counters in bag Y.  
9 of the counters are blue and the rest are red.

Arkady takes at random a counter from bag X and takes at random a counter from bag Y.

(a) Complete the probability tree diagram.

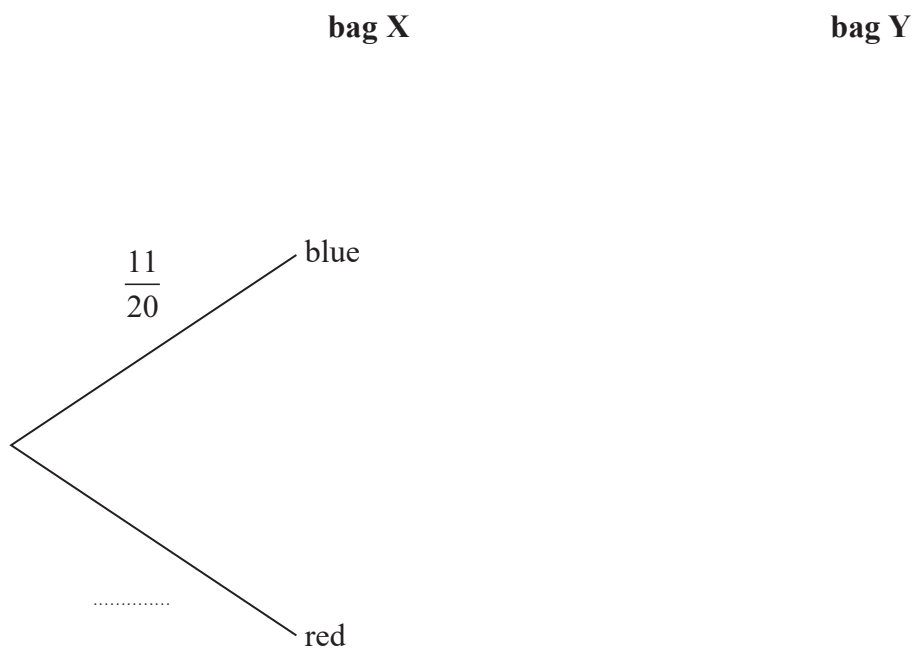

(3)

DO NOT WRITE IN THIS AREA

DO NOT WRITE IN THIS AREA

DO NOT WRITE IN THIS AREA



(b) Work out the probability that the two counters are both red.

.....  
(2)

(c) Work out the probability that the two counters are both red or are both blue.

.....  
(3)

**(Total for Question 15 is 8 marks)**

---

DO NOT WRITE IN THIS AREA

DO NOT WRITE IN THIS AREA

DO NOT WRITE IN THIS AREA



16

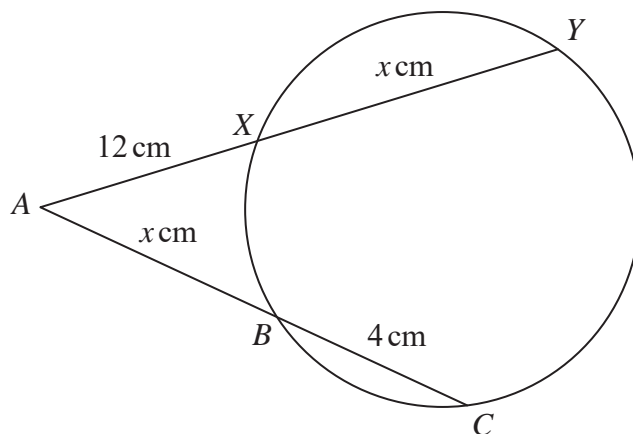

Diagram **NOT** accurately drawn

DO NOT WRITE IN THIS AREA

DO NOT WRITE IN THIS AREA

DO NOT WRITE IN THIS AREA

The points  $B, C, Y$  and  $X$  lie on a circle.

$AXY$  and  $ABC$  are straight lines.

$AX = 12 \text{ cm} \quad XY = x \text{ cm} \quad AB = x \text{ cm} \quad BC = 4 \text{ cm}$

(a) Show that  $x^2 - 8x - 144 = 0$

(3)

(b) Find the length of  $AC$ .

Show your working clearly.

Give your answer correct to 3 significant figures.

..... cm

(4)

(Total for Question 16 is 7 marks)





17 The table gives information about the areas, in hectares, of some farms in Spain.

Area ( $A$ hectares)	Frequency
$0 < A \leq 20$	40
$20 < A \leq 50$	90
$50 < A \leq 100$	140
$100 < A \leq 300$	140
$300 < A \leq 350$	40

On the grid, draw a histogram for this information.

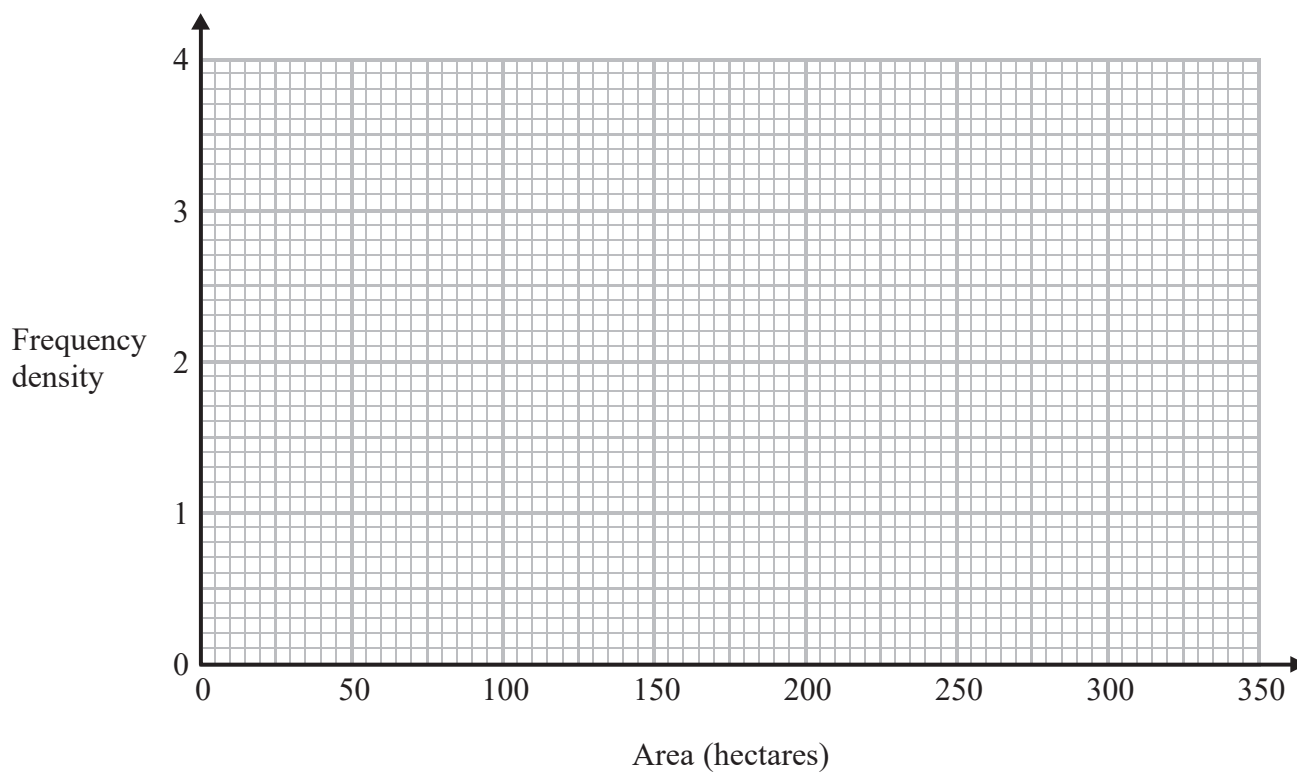

(Total for Question 17 is 3 marks)



18 Here is a quadrilateral  $PQRS$ .

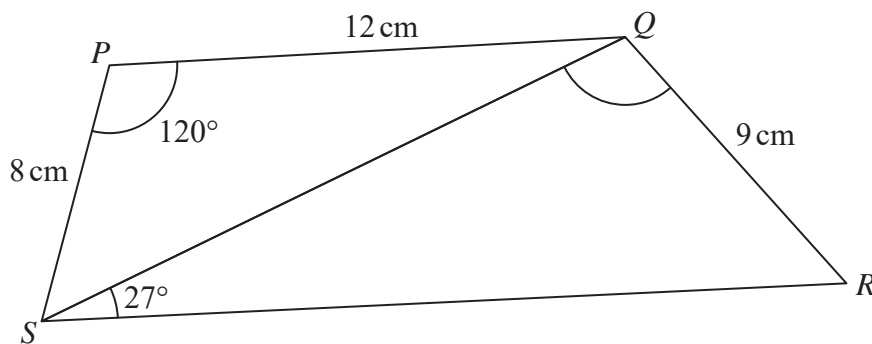

Diagram **NOT** accurately drawn

DO NOT WRITE IN THIS AREA

DO NOT WRITE IN THIS AREA

DO NOT WRITE IN THIS AREA

Angle  $SRQ$  is acute.

Work out the size of angle  $SQR$ .

Give your answer correct to 1 decimal place.

(Total for Question 18 is 6 marks)



19 The curve shown in the diagram has equation

$$y = x^3 - 27x + k \text{ where } k \text{ is a positive constant with } k < 54$$

The curve has a maximum point at  $A(a, b)$

The curve has a minimum point at  $B(c, d)$

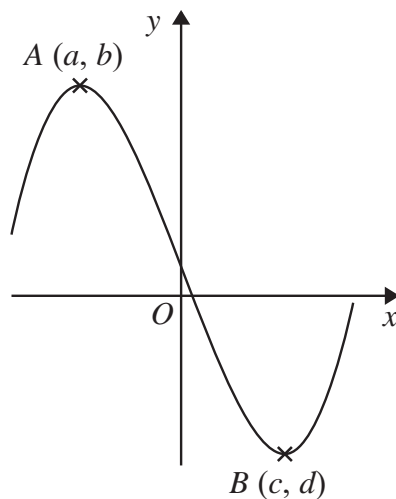

Diagram **NOT**  
accurately drawn

Using differentiation, find the value of  $b - d$   
Show your working clearly.

(Total for Question 19 is 6 marks)



20 Two functions,  $f$  and  $g$  are defined as

$$f : x \mapsto 1 + \frac{1}{x} \quad \text{for } x > 0$$

$$g : x \mapsto \frac{x+1}{2} \quad \text{for } x > 0$$

Given that  $h = fg$

express the inverse function  $h^{-1}$  in the form  $h^{-1} : x \mapsto \dots$

DO NOT WRITE IN THIS AREA

DO NOT WRITE IN THIS AREA

DO NOT WRITE IN THIS AREA

$$h^{-1} : x \mapsto \dots$$

(Total for Question 20 is 4 marks)



21 (a) Show that  $x(x - 1)(x + 1) = x^3 - x$

(1)

(b) Prove that the difference between a whole number and the cube of this number is always a multiple of 6

(3)

(Total for Question 21 is 4 marks)

DO NOT WRITE IN THIS AREA

DO NOT WRITE IN THIS AREA

DO NOT WRITE IN THIS AREA



22 A 3-D shape consists of a hollow sphere made of metal.



The diagram shows a cross section drawn through the centre,  $O$ , of the sphere.

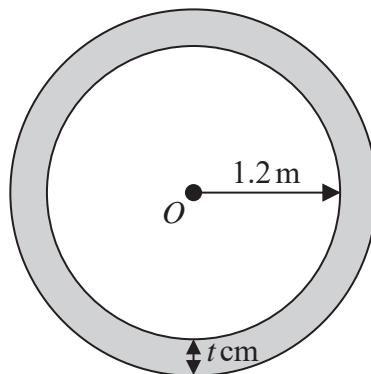

Diagram **NOT**  
accurately drawn

The internal radius of the sphere is 1.2 m.

The thickness of the metal is  $t$  cm.

The density of the metal is 2700 kg per  $\text{m}^3$

The mass of the 3-D shape is 1980 kg.

Work out the value of  $t$ .

Give your answer correct to 2 significant figures.

$t = \dots\dots\dots$

(Total for Question 22 is 5 marks)



23 Work out the sum of the multiples of 3 between 1 and 1000

DO NOT WRITE IN THIS AREA

DO NOT WRITE IN THIS AREA

DO NOT WRITE IN THIS AREA

.....  
(Total for Question 23 is 4 marks)

---

**TOTAL FOR PAPER IS 100 MARKS**



DO NOT WRITE IN THIS AREA

DO NOT WRITE IN THIS AREA

DO NOT WRITE IN THIS AREA

**BLANK PAGE**

