

Write your name here

Surname

Other names

**Pearson Edexcel**  
**International GCSE**

Centre Number

--	--	--	--	--

Candidate Number

--	--	--	--

# Mathematics A

**Level 1/2**  
**Paper 1FR**

*Model  
Solutions*



**Foundation Tier**

Thursday 24 May 2018 – Morning

**Time: 2 hours**

Paper Reference

**4MA1/1FR**

**You must have:**

Ruler graduated in centimetres and millimetres, protractor, compasses, pen, HB pencil, eraser, calculator. Tracing paper may be used.

Total Marks

## Instructions

- Use **black** ink or ball-point pen.
- **Fill in the boxes** at the top of this page with your name, centre number and candidate number.
- Answer **all** questions.
- Without sufficient working, correct answers may be awarded no marks.
- Answer the questions in the spaces provided  
– *there may be more space than you need.*
- **Calculators may be used.**
- You must **NOT** write anything on the formulae page.  
Anything you write on the formulae page will gain NO credit.

## Information

- The total mark for this paper is 100.
- The marks for **each** question are shown in brackets  
– *use this as a guide as to how much time to spend on each question.*

## Advice

- Read each question carefully before you start to answer it.
- Check your answers if you have time at the end.

Turn over ►

P59010A

©2018 Pearson Education Ltd.

1/1/1/



  
Pearson

**International GCSE Mathematics**  
**Formulae sheet – Foundation Tier**

$$\text{Area of trapezium} = \frac{1}{2}(a + b)h$$

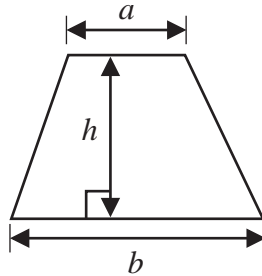

$$\text{Volume of prism} = \text{area of cross section} \times \text{length}$$

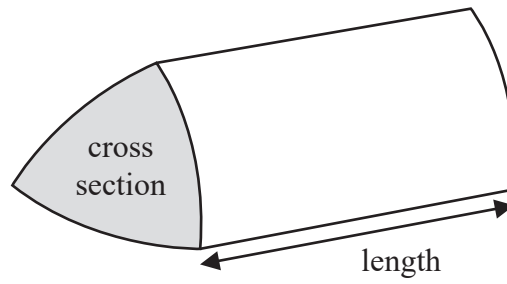

$$\text{Volume of cylinder} = \pi r^2 h$$

$$\text{Curved surface area of cylinder} = 2\pi r h$$

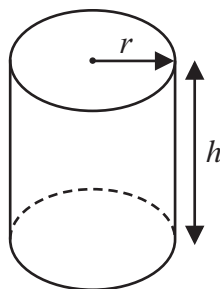

DO NOT WRITE IN THIS AREA

DO NOT WRITE IN THIS AREA

DO NOT WRITE IN THIS AREA



DO NOT WRITE IN THIS AREA

DO NOT WRITE IN THIS AREA

DO NOT WRITE IN THIS AREA

Answer ALL TWENTY SEVEN questions.

Write your answers in the spaces provided.

You must write down all the stages in your working.

1 The table gives information about the weights, in kilograms, of five animals.

Animal	Weight in kilograms
African buffalo	725
Indian elephant	3178
Giraffe	800
Pilot whale	2205
Walrus	1013

← least

(a) Which animal has the least weight?

African Buffalo .....  
(1)

(b) Write down the value of the 1 in the number 3178

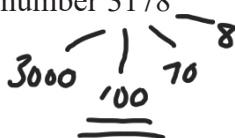

..... 100 .....  
(1)

(c) Work out the difference between 2205 and 1013

$$2205 - 1013 = \underline{\underline{1192}}$$

..... 1192 .....  
(1)

The weight of a blue whale is 20 times the weight of the giraffe.

(d) Work out the weight of the blue whale.

Give your answer in tonnes.

1 tonne = 1000 kg

Giraffe = 800 kg ← from table

$20 \times 800 = 16000 \text{ kg} = \text{blue whale}$

$\times 16$   
1 tonne = 1000 kg  
→ 16 tonne = 16000 kg

..... 16 ..... tonnes  
(2)

(Total for Question 1 is 5 marks)



- 2 A field is in the shape of a rectangle.

The width of the field is 70 m.

The length of the field is 100 m.

Fafa walks around the edge of the field 3 times.

Work out the total distance Fafa walks.

perimeter = 1 lap so find perimeter  $\times 3$

Perimeter of field  $\rightarrow 70 + 70 + 100 + 100 = 340\text{m}$

$3 \times 340 = 1020\text{ metres}$

.....1020..... m

(Total for Question 2 is 3 marks)

DO NOT WRITE IN THIS AREA

DO NOT WRITE IN THIS AREA

DO NOT WRITE IN THIS AREA



DO NOT WRITE IN THIS AREA

3 Here is a rectangle A made from centimetre squares.

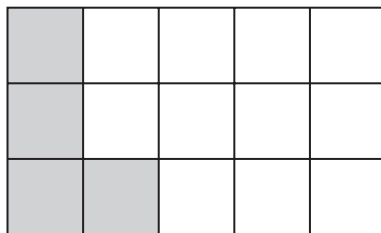

rectangle A

(a) What fraction of rectangle A is shaded?

$$\frac{\text{Shaded squares}}{\text{Total squares}} \rightarrow \frac{4}{15}$$

$$\frac{4}{15} \quad (1)$$

Rectangle B is made from centimetre squares.

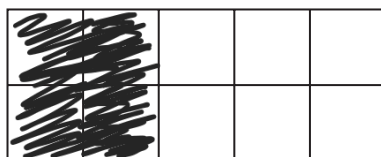

rectangle B

(b) Shade 40% of rectangle B.

$$0.4 \times 10 = \underline{4} \quad \text{so shade 4 whole squares} \quad (1)$$

(Total for Question 3 is 2 marks)

DO NOT WRITE IN THIS AREA

DO NOT WRITE IN THIS AREA



4

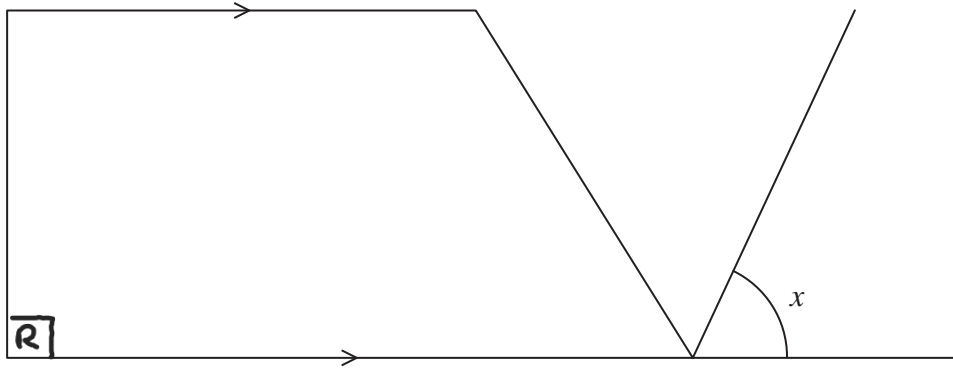

(a) On the diagram, mark a right angle with the letter R.

(1)

There is a quadrilateral in the diagram.

(b) Write down the mathematical name of this quadrilateral.

Trapezium

(1)

(c) Measure the size of angle x.

Use protractor

65°

(1)

(Total for Question 4 is 3 marks)

DO NOT WRITE IN THIS AREA

DO NOT WRITE IN THIS AREA

DO NOT WRITE IN THIS AREA



5 A, B and C are three points marked on a grid.

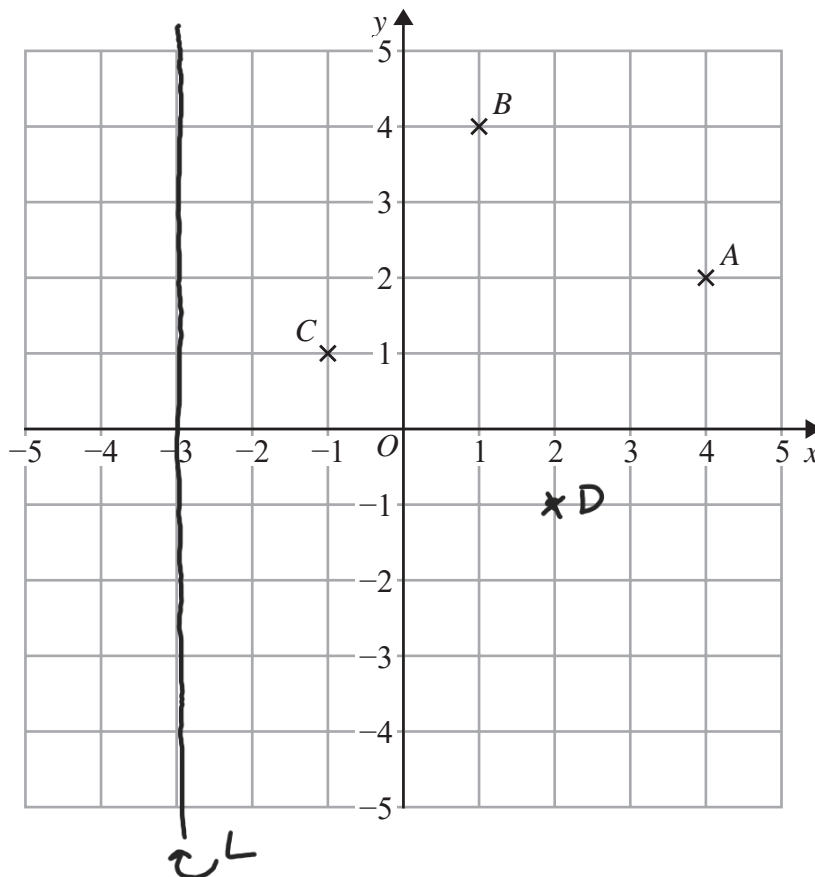

(a) On the grid, draw the line with equation  $x = -3$   
Label the line L.

(1)

M is the midpoint of AB. *M is halfway between A and B*

(b) Find the coordinates of M.

$$A \rightarrow (4, 2) \quad \left( \frac{4+1}{2}, \frac{2+4}{2} \right) = (2.5, 3)$$

$$B \rightarrow (1, 4)$$

(2.5, 3)  
(2)

D is the point so that ABCD is a square.

(c) Find the coordinates of D.

*B to A is 3 down 2 right*  
*So C to D is 3 down 2 right*

(2, -1)  
(2)

(Total for Question 5 is 5 marks)

DO NOT WRITE IN THIS AREA

DO NOT WRITE IN THIS AREA

DO NOT WRITE IN THIS AREA



6 Here is a number machine.

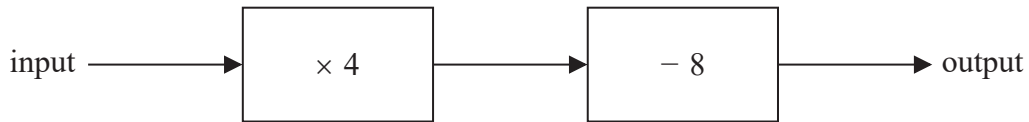

(a) Work out the output when the input is 18

$$18 \times 4 = 72$$

$$72 - 8 = 64$$

64

(1)

(b) Work out the input when the output is 20

$$20 + 8 = 28$$

$$28 \div 4 = 7$$

7

(2)

Here is a different number machine.



For this number machine, when the input is 8 the output is 50

(c) Work out the value of  $x$ .

$$(8 \times 5) + x = 50$$

$$40 + x = 50$$

$$\underline{\underline{x = 10}}$$

$x = 10$

(2)

(Total for Question 6 is 5 marks)

DO NOT WRITE IN THIS AREA

DO NOT WRITE IN THIS AREA

DO NOT WRITE IN THIS AREA





DO NOT WRITE IN THIS AREA

DO NOT WRITE IN THIS AREA

DO NOT WRITE IN THIS AREA

7 Here is a list of all the nut trees Caterina counted one day.

cashew	pistachio	almond	cashew	almond
walnut	walnut	almond	pistachio	cashew
cashew	walnut	almond	walnut	pistachio
almond	walnut	pistachio	walnut	walnut

(a) Complete the frequency table for Caterina's list.

Nut tree	Tally	Frequency
cashew		4
walnut		7
almond		5
pistachio		4

(2)

(b) Draw a bar chart for the information in your table.

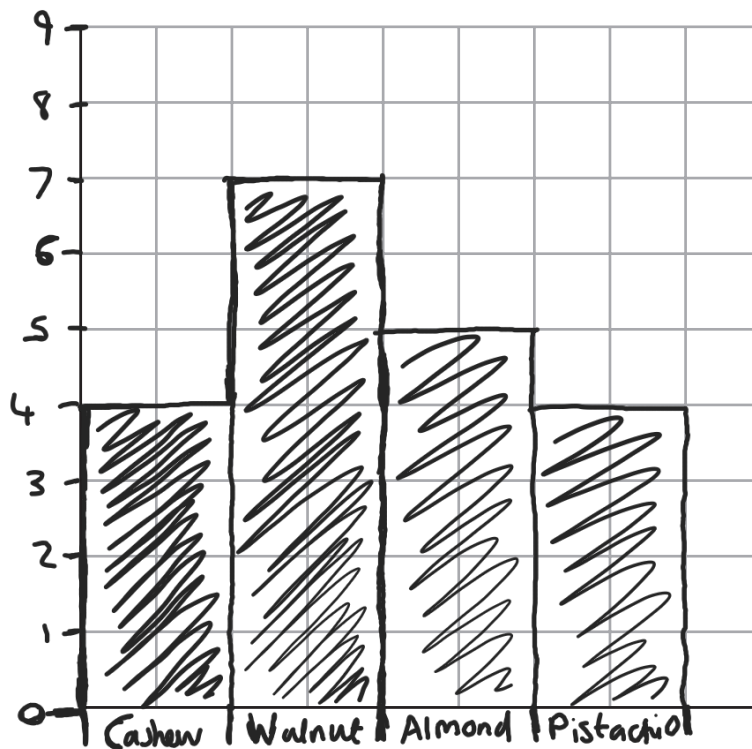

(3)

(Total for Question 7 is 5 marks)



8 (a) Simplify  $y \times y \times y$

$$y^{1+1+1} = y^3$$

$$\frac{y^3}{(1)}$$

(b) Simplify  $3c \times 2d$

$$3 \times 2 \times c \times d = 6 \times c \times d$$

$$\frac{6cd}{(1)}$$

(c) Simplify  $2k - 4k + 3k$

$$= -2k + 3k$$

$$= k$$

$$\frac{k}{(1)}$$

(Total for Question 8 is 3 marks)

DO NOT WRITE IN THIS AREA

DO NOT WRITE IN THIS AREA

DO NOT WRITE IN THIS AREA



9 The table shows the temperatures at midnight and at midday at five ski resorts.

Ski resort	Temperature at midnight (°C)	Temperature at midday (°C)
Chamonix	-5	3
Alto Campoo	-8	-2
Javornik	-5	-4
La Parva	-2	-2
Asiago	-7	0

(a) Which ski resort had the lowest temperature at midnight?

Alto Campoo (1)

(b) Work out the increase in temperature from midnight to midday for Chamonix.

$-5 \rightarrow 3$   
 $+8$   
8 ..... °C (1)

Jan knows that the temperature falls by 1 °C for every 300m increase in height above Asiago.

(c) What was the temperature at midnight at a height 1800m above Asiago?

$\frac{1800}{300} = 6^\circ\text{C fall}$   
 $-7 - 6 = \underline{\underline{-13^\circ\text{C}}}$   
 ..... °C (2)

(Total for Question 9 is 4 marks)

DO NOT WRITE IN THIS AREA

DO NOT WRITE IN THIS AREA

DO NOT WRITE IN THIS AREA



10 There are 20 counters in bag X.

7 of the counters are green.

10 of the counters are red.

The rest of the counters are blue.

Ruth takes at random a counter from bag X.

(a) Write down the probability that the counter is red.

$$\frac{10}{20}$$

$$\frac{10}{20}$$

(1)

(b) Work out the probability that the counter is blue.

$$20 - (7 + 10) = \underline{\underline{3 \text{ blue}}}$$

$$3 \text{ out of } 20 = \frac{3}{20}$$

$$\frac{3}{20}$$

(1)

Ruth puts the counter back into bag X.

Bag Y only contains green counters, red counters and blue counters.

In bag Y there are,

2 more green counters than in bag X

1 more red counter than in bag X

2 more blue counters than in bag X

Adam takes at random a counter from bag Y.

Ruth takes at random a counter from bag X.

(c) Who has the greater probability of taking a green counter, Adam or Ruth?

Show your working clearly.

$$\begin{aligned} \text{Adam} \rightarrow \text{Bag Y} \rightarrow & \begin{array}{l} 7 + 2 = 9 \text{ green} \\ 10 + 1 = 11 \text{ red} \\ 3 + 2 = 5 \text{ blue} \\ \hline 25 \text{ total} \end{array} \end{aligned}$$

$$\rightarrow \text{green} = \frac{9}{25} = \underline{\underline{0.36}}$$

$$\text{Ruth} \rightarrow \text{Bag X} \rightarrow \frac{7}{20} \text{ green} = \underline{\underline{0.35}}$$

$$\text{Bag Y} > \text{Bag X}$$

$$\text{Adam} > \text{Ruth}$$

$$0.36 > 0.35$$

So Adam has greater chance

(3)

(Total for Question 10 is 5 marks)

DO NOT WRITE IN THIS AREA

DO NOT WRITE IN THIS AREA

DO NOT WRITE IN THIS AREA



- 11 A sequence is formed by adding 1 to each square number.  
Here are the first five terms of the sequence.

2      5      10      17      26

- (a) Find the 10th term of the sequence.

$$(10 \times 10) + 1 = 100 + 1 = 101$$

.....101.....  
(1)

1025 is a term of this sequence.

- (b) Which term?

$$1025 - 1 = 1024$$

$$\sqrt{1024} = 32$$

.....32.....  
(2)

(Total for Question 11 is 3 marks)

DO NOT WRITE IN THIS AREA

DO NOT WRITE IN THIS AREA

DO NOT WRITE IN THIS AREA



12

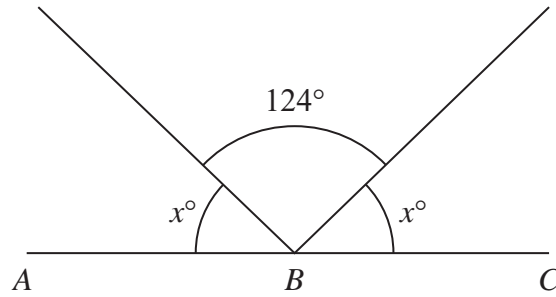

Diagram **NOT** accurately drawn

ABC is a straight line.  
Work out the value of  $x$ .

$$180 - 124 = 2x$$

$$\div 2 \quad \left( \begin{array}{l} 56 = 2x \\ \rightarrow 28 = x \end{array} \right) \div 2$$

$x = 28$

(Total for Question 12 is 3 marks)

13 Show that  $\frac{7}{8} - \frac{1}{6} = \frac{17}{24}$

$$\frac{7}{8} = \frac{21}{24}$$

(Handwritten:  $\times 3$  above the arrow from 8 to 24, and  $\times 3$  below the arrow from 7 to 21)

$$\frac{1}{6} = \frac{4}{24}$$

(Handwritten:  $\times 4$  above the arrow from 6 to 24, and  $\times 4$  below the arrow from 1 to 4)

make a common denominator

$$\frac{7}{8} - \frac{1}{6} = \frac{21}{24} - \frac{4}{24} = \frac{17}{24} \quad 21 - 4 = 17$$

(Total for Question 13 is 2 marks)

DO NOT WRITE IN THIS AREA

DO NOT WRITE IN THIS AREA

DO NOT WRITE IN THIS AREA



14  $y = c - dx$

$$c = 15$$

$$d = 8$$

$$x = -4$$

(a) Work out the value of  $y$ .

$$y = (15) - (8)(-4)$$

$$y = 15 - -32 \quad 8 \times -4 = -32$$

$$y = \underline{47}$$

$$y = \underline{47} \quad (2)$$

$$t = 4(p - q)$$

$$t = 18$$

$$q = 6$$

(b) Work out the value of  $p$ .

$$18 = 4(p - 6)$$

$$\frac{18}{4} = p - 6$$

$$4.5 = p - 6$$

$$4.5 + 6 = p$$

$$= \underline{10.5}$$

$$p = \underline{10.5} \quad (2)$$

(Total for Question 14 is 4 marks)

DO NOT WRITE IN THIS AREA

DO NOT WRITE IN THIS AREA

DO NOT WRITE IN THIS AREA



- 15 There are 440 students at a school.  
The number of male students is 40 more than the number of female students.

65% of the male students like art.  
85% of the female students like art.

Work out the total number of students at the school who like art.

240 male students  
200 female students

$240 \times 0.65 = 156$  males like art  
 $200 \times 0.85 = 170$  females like art

$156 + 170 = 326$  total

326

(Total for Question 15 is 4 marks)

DO NOT WRITE IN THIS AREA

DO NOT WRITE IN THIS AREA

DO NOT WRITE IN THIS AREA





16 Here is a hexagon  $ABCDEF$ .

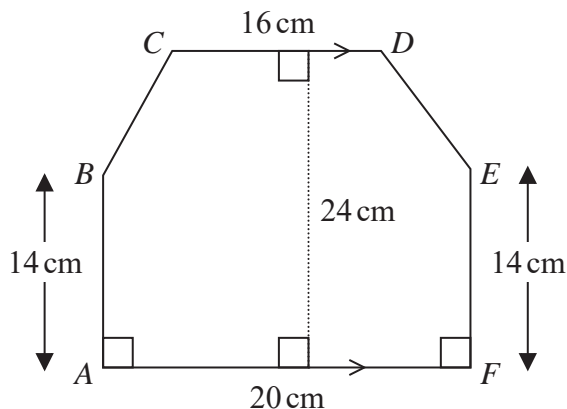

Diagram NOT accurately drawn

$CD$  is parallel to  $AF$ .

Work out the area of hexagon  $ABCDEF$ .

First work out  $ABEF$  area  $\rightarrow 20 \times 14 = 280 \text{ cm}^2$   
 Then  $BCDE \rightarrow \frac{20+16}{2} \times (24-14) \rightarrow 18 \times 10 = 180 \text{ cm}^2$   
 $280 + 180 = 460 \text{ cm}^2$

..... 460 .....  $\text{cm}^2$

(Total for Question 16 is 4 marks)

DO NOT WRITE IN THIS AREA

DO NOT WRITE IN THIS AREA

DO NOT WRITE IN THIS AREA



17

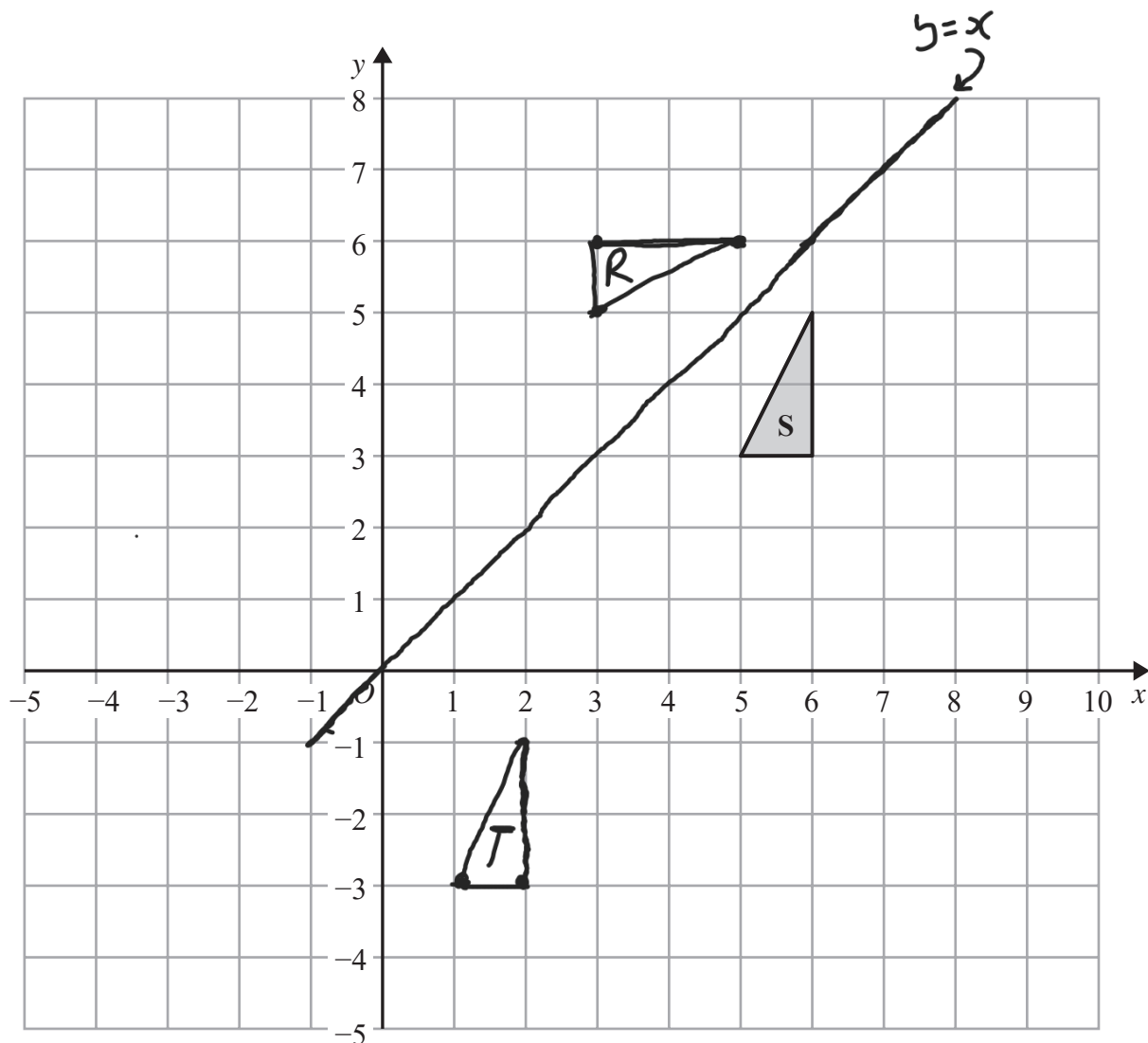

DO NOT WRITE IN THIS AREA

DO NOT WRITE IN THIS AREA

DO NOT WRITE IN THIS AREA

(a) Reflect triangle **S** in the line  $y = x$   
Label the new triangle **R**.

(2)

(b) Translate triangle **S** by the vector  $\begin{pmatrix} -4 \\ -6 \end{pmatrix}$  *move 4 units left*  
*move 6 units down*  
Label the new triangle **T**.

(1)



DO NOT WRITE IN THIS AREA

DO NOT WRITE IN THIS AREA

DO NOT WRITE IN THIS AREA

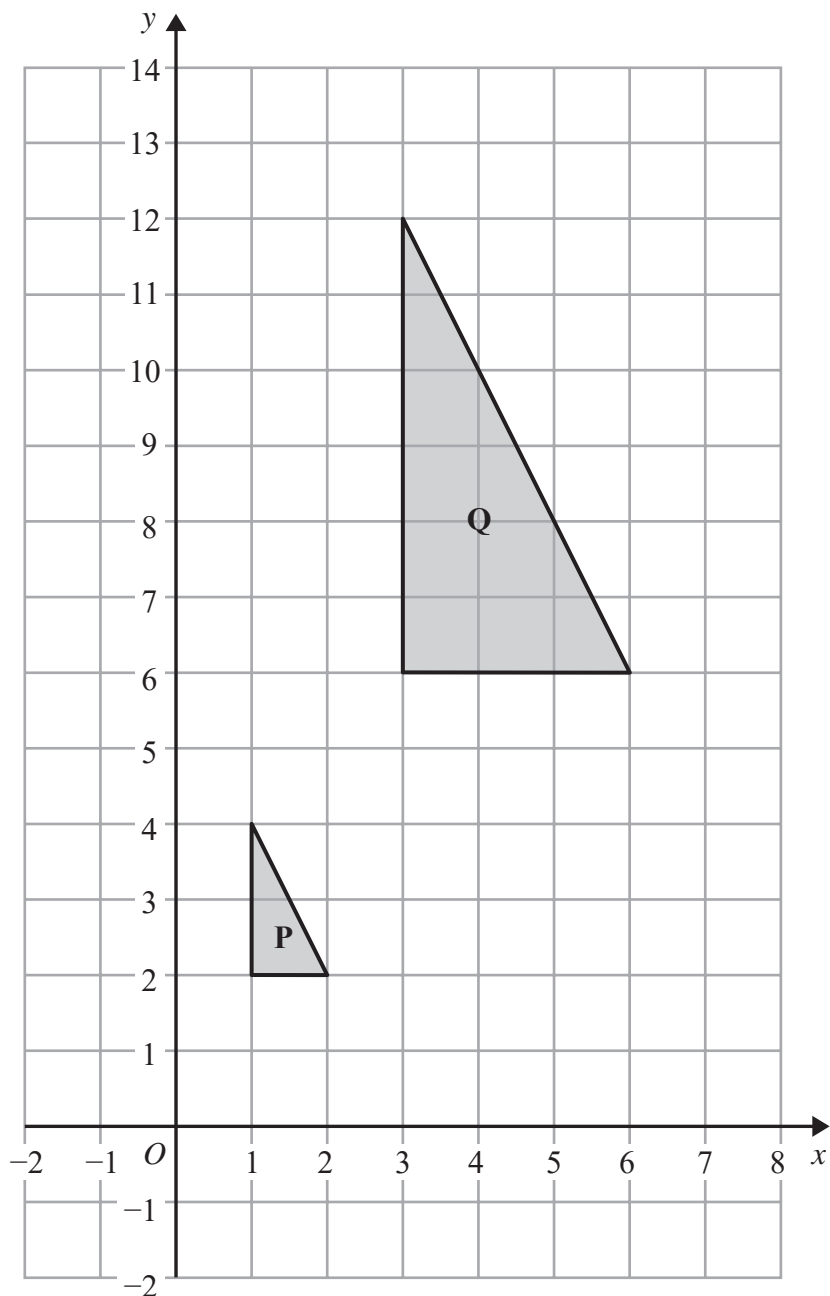

(c) Describe fully the single transformation that maps triangle P onto triangle Q.

*Enlargement by scale factor 3 from  
centre (0,0).*

(2)

(Total for Question 17 is 5 marks)



- 18 The table gives information about the times, in hours, some students spent doing sport one week.

Time ( $T$ hours)	Frequency	Midpoint	$M \times F$
$0 < T \leq 2$	5	1	5
$2 < T \leq 4$	9	3	27
$4 < T \leq 6$	24	5	120
$6 < T \leq 8$	40	7	280
$8 < T \leq 10$	7	9	63
			495

Calculate an estimate for the mean time these students spent doing sport. Give your answer in hours, correct to 1 decimal place.

$$\frac{495}{85} = 5.8 \quad \text{mean} = \frac{\text{sum total}}{\text{number of values}}$$

..... 5.8 ..... hours

(Total for Question 18 is 4 marks)

DO NOT WRITE IN THIS AREA

DO NOT WRITE IN THIS AREA

DO NOT WRITE IN THIS AREA



19 Anna and Lionel share \$675 in the ratio 4 : 5

Lionel gives  $\frac{3}{5}$  of his share of the money to his mother.

How much money does Lionel give to his mother?

$$A : L$$

$$4 : 5 \rightarrow \text{Total 9 parts of 675}$$

$$\text{Lionel has } \frac{5}{9} \text{ of 675} \rightarrow \frac{5}{9} \times 675 = \$375$$

$$\frac{3}{5} \text{ of } \$375 \text{ to mother} \rightarrow \frac{3}{5} \times 375 = \$225$$

$$\$ \underline{225}$$

(Total for Question 19 is 3 marks)

20  $E = n^2 + n + 5$

(a) Work out the value of  $E$  when  $n = 3$

$$\begin{aligned} E &= (3)^2 + (3) + 5 \\ &= 9 + 3 + 5 \\ &= 17 \end{aligned}$$

$$E = \underline{17} \quad (1)$$

Ali thinks that the value of  $E$  will be a prime number for any whole number value of  $n$ .

(b) Is Ali correct?

You must give a reason for your answer.

No, because if we take 5 as  $n$ , the result is not prime

$$\begin{aligned} E &= (5)^2 + (5) + 5 = 25 + 5 + 5 = \underline{35} \\ 35 \text{ is not prime} &\rightarrow 7 \times 5 = 35 \end{aligned} \quad (2)$$

(Total for Question 20 is 3 marks)

DO NOT WRITE IN THIS AREA

DO NOT WRITE IN THIS AREA

DO NOT WRITE IN THIS AREA

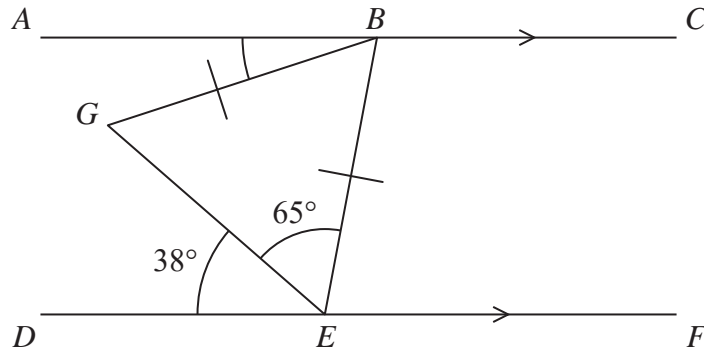

21

Diagram **NOT**  
accurately drawn $ABC$  and  $DEF$  are parallel lines.

$$BG = BE$$

$$\text{Angle } DEG = 38^\circ$$

$$\text{Angle } GEB = 65^\circ$$

Find the size of angle  $ABG$ .

$$ABE \rightarrow 180 - (38 + 65) = 77^\circ$$

$$GBE \rightarrow 180 - (2 \times 65) = 50^\circ$$

$$ABG \rightarrow 77 - 50 = 27^\circ$$

27

(Total for Question 21 is 3 marks)

DO NOT WRITE IN THIS AREA

DO NOT WRITE IN THIS AREA

DO NOT WRITE IN THIS AREA



DO NOT WRITE IN THIS AREA

DO NOT WRITE IN THIS AREA

DO NOT WRITE IN THIS AREA

22 Here are the first four terms of an arithmetic sequence.



(a) Find an expression, in terms of  $n$ , for the  $n$ th term of this sequence.

Goes up by +4 so  $4n$   
 0th term is 2  
 So  $4n + 2$

$4n + 2$   
 (2)

(b) Write down an expression, in terms of  $n$ , for the  $(n + 1)$ th term of this sequence.

$4n + 2$   $\rightarrow$   $4(n+1) + 2 \rightarrow 4n + 4 + 2$   
 $4n + 6$

$4n + 6$   
 (1)

(Total for Question 22 is 3 marks)

23 (a) Write 1 390 000 in standard form.

$1.390000$   $\rightarrow$   $1.39 \times 10^6$

$1.39 \times 10^6$   
 (1)

(b) Write 0.005 in standard form.

$5.0 \times 10^{-3}$

$5 \times 10^{-3}$   
 (1)

(Total for Question 23 is 2 marks)



24 Here is an empty pool in the shape of a cuboid.

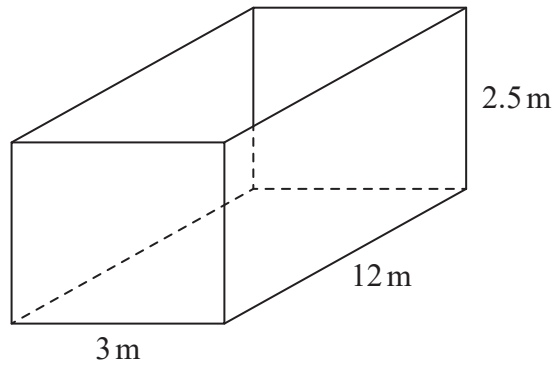

Diagram **NOT** accurately drawn

The width of the pool is 3 m.

The length of the pool is 12 m.

The top of the pool is 2.5 m above the base of the pool.

Jeb is going to put water in the pool.

The level of the surface of the water will be 60 cm below the top of the pool.

Water flows into the pool at 400 litres per minute.

$1 \text{ m}^3 = 1000 \text{ litres}$

How long will it take to fill the pool to 60 cm below the top of the pool?

Give your answer in hours and minutes.

Height of pool is 2.5 metres = 250 cm

So  $-60 \text{ cm} \rightarrow 250 - 60 = 190 \text{ cm}$  will be target height.  
 $= \underline{1.9 \text{ m}}$

Volume  $\rightarrow 1.9 \times 3 \times 12 = \underline{68.4 \text{ m}^3}$

400 litres per minute  $\rightarrow 0.4 \text{ m}^3$  per minute.

$\frac{68.4}{0.4} = \underline{171 \text{ minutes}}$

171 minutes = 120 minutes + 51 minutes  
 2 hours + 51 minutes

.....2..... hours .....51..... minutes

(Total for Question 24 is 4 marks)

DO NOT WRITE IN THIS AREA

DO NOT WRITE IN THIS AREA

DO NOT WRITE IN THIS AREA





25 Solve

$$\begin{aligned} 3x + 2y &= 15 \\ 10x - 4y &= 2 \end{aligned}$$

Show clear algebraic working.

$$\textcircled{1} \quad 3x + 2y = 15$$

$$\textcircled{2} \quad 10x - 4y = 2$$

$$\begin{array}{r} \textcircled{1} \times 2 \rightarrow 6x + 4y = 30 \\ \textcircled{2} \times 1 \rightarrow 10x - 4y = 2 \quad + \\ \hline 16x + 0y = 32 \\ x = \underline{2} \end{array}$$

$$\begin{aligned} \textcircled{1} \quad 3x + 2y &= 15 \\ 3(2) + 2y &= 15 \\ 6 + 2y &= 15 \\ 2y &= 9 \\ y &= 4.5 \end{aligned}$$

$$x = \underline{2}$$

$$y = \underline{4.5}$$

(Total for Question 25 is 3 marks)

26 Change a speed of 72 kilometres per hour to a speed in metres per second.

$$72 \text{ km} \rightarrow 72000 \text{ metres} \\ \times 1000$$

$$1 \text{ hour} \rightarrow 60 \text{ minutes} \rightarrow 3600 \text{ seconds}$$

$$\frac{72000}{3600} = 20 \text{ m/s}$$

$$\dots\dots\dots 20 \dots\dots\dots \text{ metres per second}$$

(Total for Question 26 is 3 marks)



27 A company makes cars.

In 2016, the company made 350 cars.

In the first 6 months of 2017, the company made 25 cars each month.

In the last 6 months of 2017, the company made 45 cars each month.

(a) Work out the percentage increase in the number of cars the company made from 2016 to 2017

$$2016 \rightarrow 350 \text{ cars}$$

$$2017 \rightarrow (25 \times 6) + (45 \times 6) = 420 \text{ cars}$$

$$350 \times x = 420$$

$$\frac{420}{350} = 1.2 = 20\% \text{ increase}$$

..... 20 ..... %  
(4)

The company's income in 2017 was \$500 000 more than the company's income in 2016

The company's income in 2017 was 8% more than the company's income in 2016

(b) Work out the company's income in 2016

$$\begin{aligned}
 & \$500,000 = 8\% \\
 & \xrightarrow{\div 8} \$62,500 = 1\% \\
 & \xrightarrow{\times 100} \underline{\underline{\$6,250,000}}
 \end{aligned}$$

\$ 6,250,000 .....  
(3)

(Total for Question 27 is 7 marks)

TOTAL FOR PAPER IS 100 MARKS



DO NOT WRITE IN THIS AREA

DO NOT WRITE IN THIS AREA

DO NOT WRITE IN THIS AREA

**BLANK PAGE**



DO NOT WRITE IN THIS AREA

DO NOT WRITE IN THIS AREA

DO NOT WRITE IN THIS AREA

**BLANK PAGE**

