

Surname	Centre Number	Candidate Number
Other Names		0



GCSE – NEW

3300U10-1



**MATHEMATICS
UNIT 1: NON-CALCULATOR
FOUNDATION TIER**

TUESDAY, 13 JUNE 2017 – MORNING

1 hour 30 minutes

ADDITIONAL MATERIALS

The use of a calculator is not permitted in this examination.
A ruler, protractor and a pair of compasses may be required.

INSTRUCTIONS TO CANDIDATES

Use black ink or black ball-point pen. Do not use gel pen or correction fluid.

You may use a pencil for graphs and diagrams only.

Write your name, centre number and candidate number in the spaces at the top of this page.

Answer **all** the questions in the spaces provided.

If you run out of space, use the continuation page at the back of the booklet, taking care to number the question(s) correctly.

Take π as 3.14.

INFORMATION FOR CANDIDATES

You should give details of your method of solution when appropriate.

Unless stated, diagrams are not drawn to scale.

Scale drawing solutions will not be acceptable where you are asked to calculate.

The number of marks is given in brackets at the end of each question or part-question.

In question **10**, the assessment will take into account the quality of your linguistic and mathematical organisation, communication and accuracy in writing.

For Examiner's use only		
Question	Maximum Mark	Mark Awarded
1.	5	
2.	2	
3.	2	
4.	2	
5.	5	
6.	4	
7.	3	
8.	2	
9.	3	
10.	5	
11.	4	
12.	3	
13.	2	
14.	3	
15.	2	
16.	2	
17.	6	
18.	5	
19.	5	
Total	65	



JUN173300U10101

Formula List - Foundation Tier

Area of trapezium $= \frac{1}{2}(a + b)h$

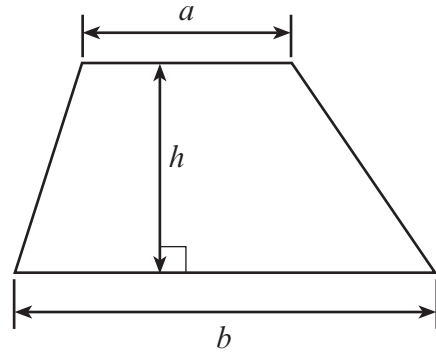

Examiner only

1. (a) Write the number fifty thousand and four in figures. [1]

.....

(b) Calculate £7.20 divided by 9.
Write your answer in pence. [2]

.....
.....
.....

Answer: pence

(c) Mair thought of two whole numbers.
When she multiplied them together, the answer was 20.
When she added them together, the answer was 9.
What are the two numbers that Mair thought of? [2]

.....
.....
.....

Numbers are and

3300U101
03



2.

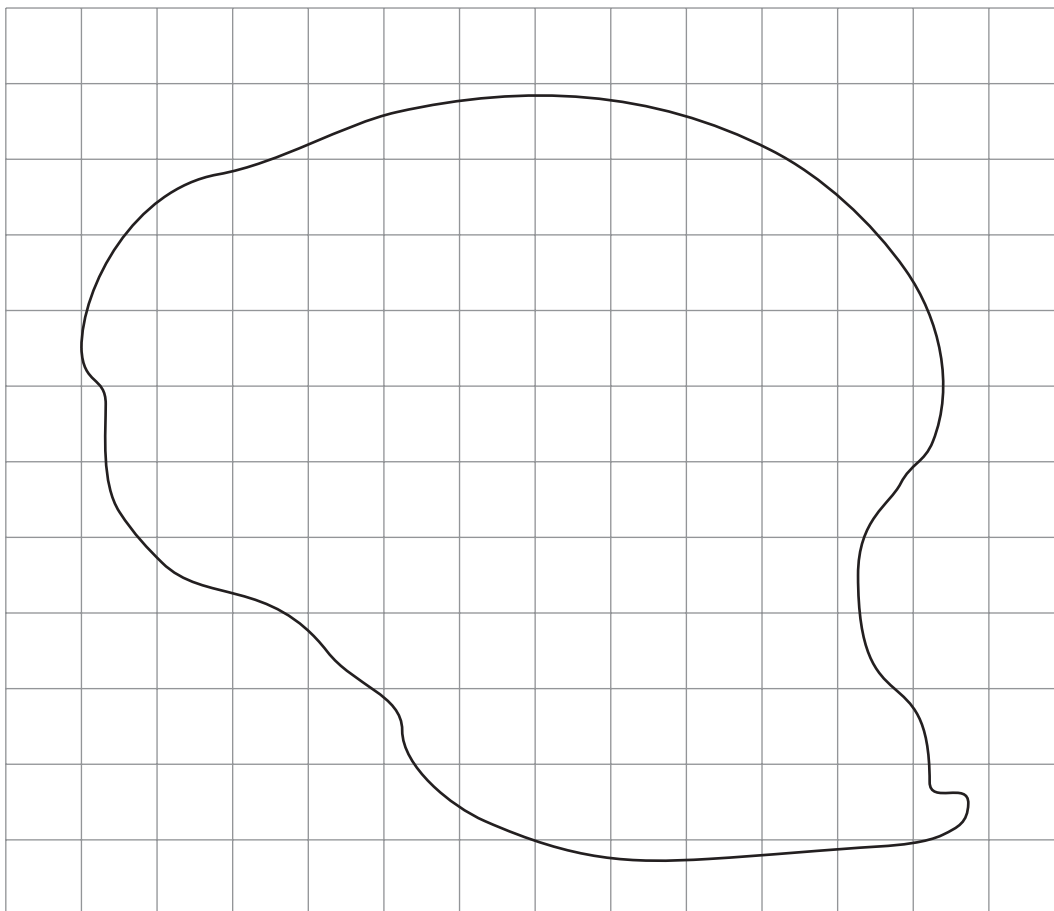

The shape above has been drawn on a centimetre square grid.
Estimate the area of the shape.

[2]

.....

.....

.....

.....

Area of the shape = cm²



3. Shade the smallest number of squares needed to make the line AB a line of symmetry. [2]

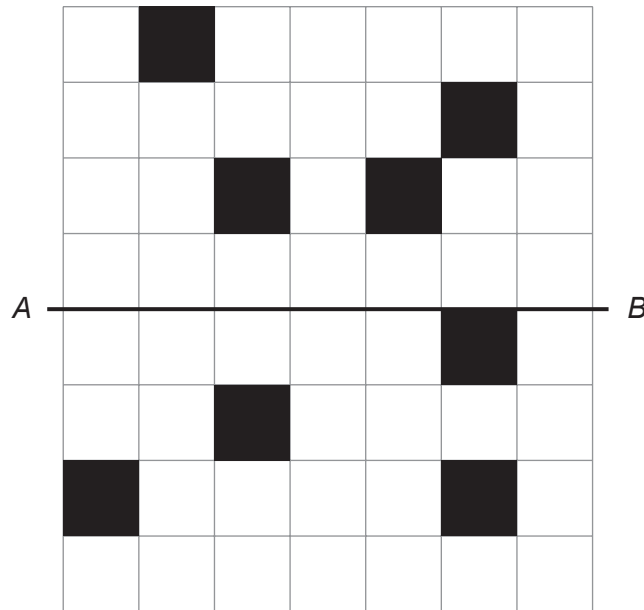

4. (a)

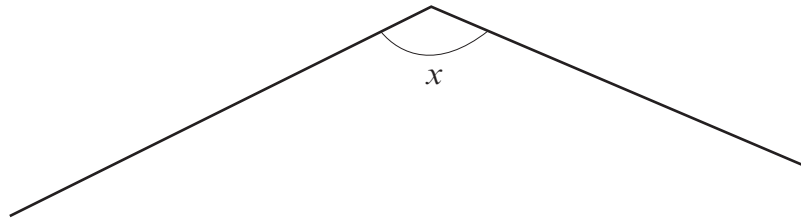

What type of angle is x in the diagram above?
Circle your answer.

[1]

right angle

reflex

obtuse

acute

(b)

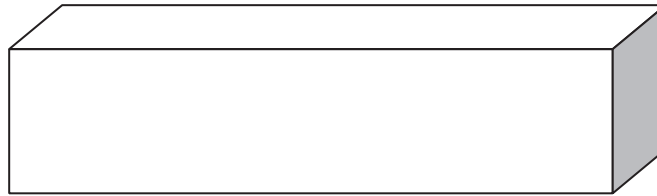

What is the special name of the shape drawn above?
Circle your answer.

[1]

sphere

cube

cone

cuboid

cylinder



5. Blues, Dragons, Ospreys and Scarlets are four Welsh rugby teams. Aled asked a group of 170 pupils which of these 4 teams they preferred. He then drew this bar chart to show the data that he had collected.

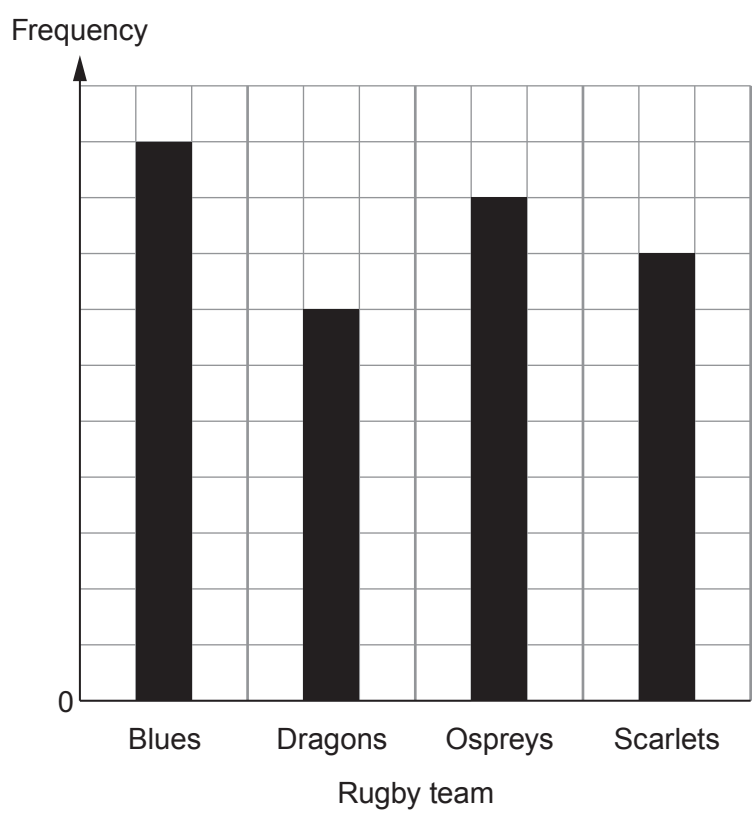

(a) Aled knew that 50 of these pupils said that they preferred the Blues. Complete the table below. [3]

.....

.....

Rugby team preferred	Number of pupils
Blues	50
Dragons	
Ospreys	
Scarlets	

(b) A pupil is chosen at random from this group. What is the probability that this pupil preferred the Blues? [2]

.....

.....



6. (a) The points A and B are plotted on the grid below.
Write down the coordinates of A and B .

[2]

A (..... ,) B (..... ,)

- (b) The point C is the midpoint of the line AB .
Find the coordinates of C .

[2]

C (..... ,)

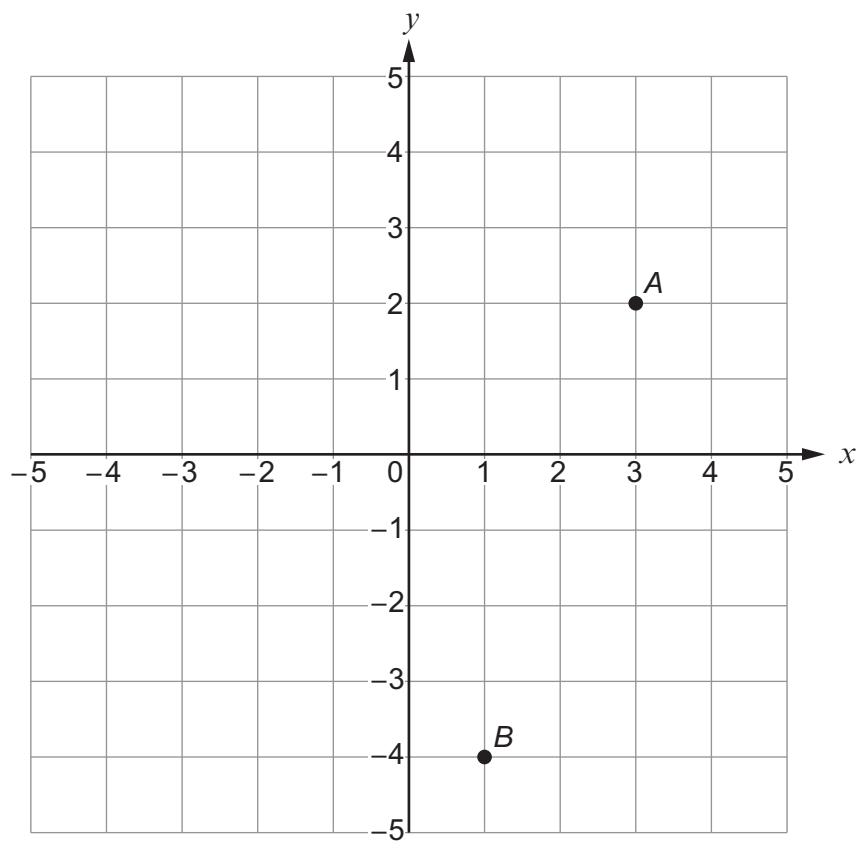

7. (a) Solve these equations.

(i) $7x = 56$

[1]

.....

.....

.....

(ii) $y + 19 = 83$

[1]

.....

.....

(b) Simplify the expression $12k - 15k + 7k$.

[1]

.....

8. (a) Write down the value of 9^2 .

[1]

.....

(b) Work out 1.2×70 .

[1]

.....

.....

.....

.....

.....



9. Use a ruler and a protractor to make an accurate drawing of this triangle.

[3]

Examiner
only

Diagram not drawn to scale



10. In this question, you will be assessed on the quality of your organisation, communication and accuracy in writing.

The diagram shows **part** of a rectangle and some identical circles drawn inside the rectangle. The circles touch each other or the sides of the rectangle, as shown in the diagram.

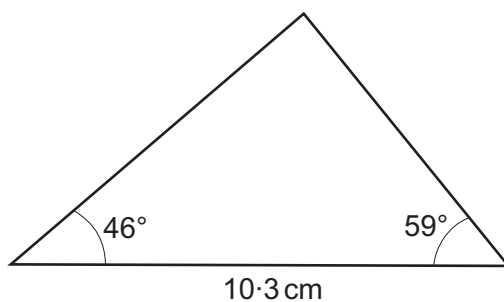
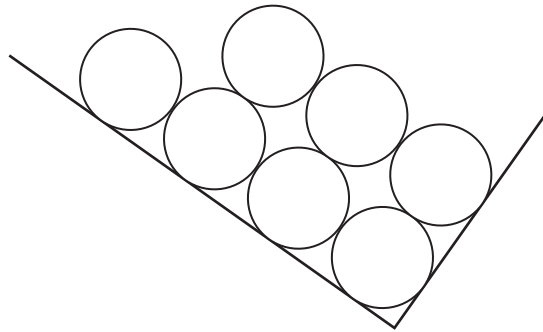

Diagram not drawn to scale

The rectangle measures 30 cm by 1 m.
The diameter of every circle is 5 cm.

What is the largest number of circles that will fit into this rectangle?
The circles must be arranged in the way shown above.
You must show all your working.

[3 + 2 OCW]

.....

.....

.....

.....

.....

.....

.....

.....

.....

.....



11. (a) Write down the next two numbers in the following sequence. [2]

35, 25, 16, 8, ,

.....
.....

(b) Find the value of $2x + 7y$ when $x = -3$ and $y = 10$. [2]

.....
.....
.....

12. Write down 0.4, 15% and $\frac{7}{20}$ in ascending order.

You must show all your working.

[3]

.....
.....
.....
.....
.....

.....

Smallest value \longrightarrow Greatest value



Examiner
only

13. Enlarge the triangle below by a scale factor of 3.

[2]

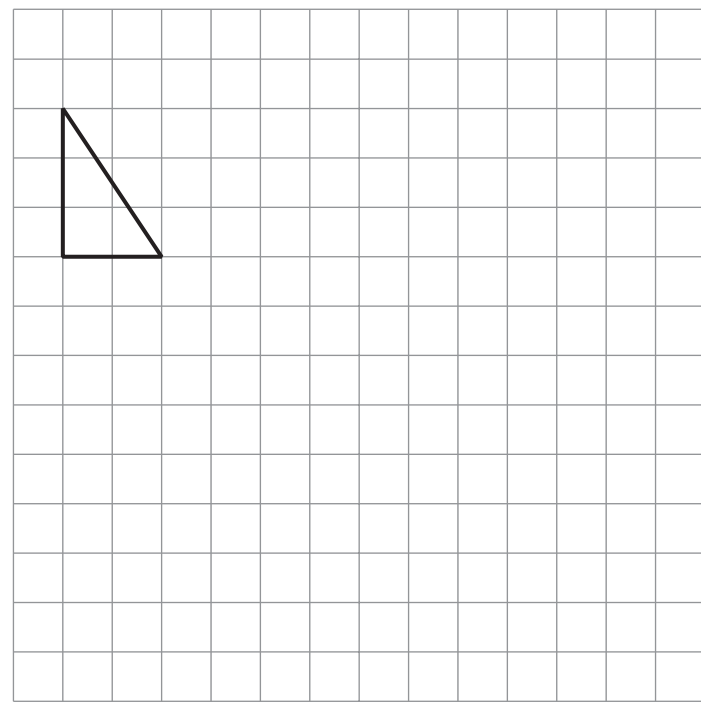

14. (a) A fair, six-sided dice is rolled.
What is the probability that a 4 is shown on the dice?
Circle your answer.

[1]

6% $\frac{1}{5}$ $\frac{1}{4}$ 6:1 $\frac{1}{6}$

- (b) 50 raffle tickets were sold at a charity event.
Sian has a 20% chance of winning the top prize.
How many tickets did Sian buy?
Circle your answer.

[1]

1 2 4 10 20

- (c) A bag contains a mixture of blue beads, yellow beads and pink beads.
One bead is taken at random from the bag.

The probability that the bead is pink is $\frac{1}{5}$.

Which of the following sets of beads could have been in the bag?
Circle your answer.

[1]



Examiner
only

15. Team A and Team B play in a competition.

Team A has nine more points than Team B.
Team A has four times as many points as Team B.

How many points does each team have? [2]

.....

.....

.....

.....

.....

Team A: points

Team B: points



- 16.** David, Jane and Mary are beach inspectors.
Three beaches, Harlech, Rhyl and Porthcawl, are all to be inspected on a certain day.
It is decided to share the work so that the inspectors will visit one beach each, chosen at random.

List all the possible different ways they could share the work.
One has been done for you.

[2]

David → Harlech, Jane → Rhyl and Mary → Porthcawl



17. $ABCD$ is a quadrilateral.

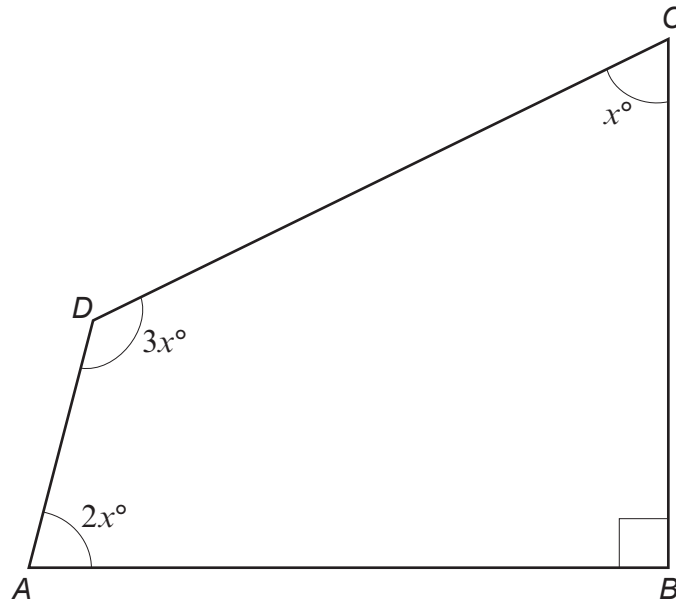

Diagram not drawn to scale

(a) Calculate the value of x .

[4]

.....

.....

.....

.....

.....

(b) When $ABCD$ is drawn to scale, would the lines AD and BC be parallel or not?
You must justify your answer without using a scale drawing.

[2]

.....

.....

.....

.....



18. (a) Estimate the value of $\frac{41.3 \times 29.6}{198.7}$.

You must show all your working.

[2]

.....

.....

.....

.....

.....

(b) Given that $54 \times 84.2 = 4546.8$, write down the exact value of each of the following.

(i) $540 \times 842 =$ [1]

(ii) $\frac{4546.8}{5.4} =$ [1]

(iii) $\frac{454.68}{84.2} =$ [1]



19. In the diagram below,
- $ABCD$ is a rectangle, and
 - PQ is parallel to AD .

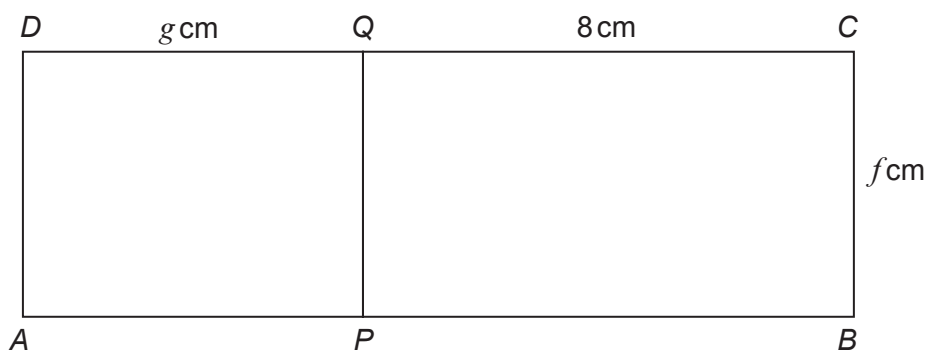

Diagram not drawn to scale

The area of $ABCD$ is 52 cm^2 .
The area of $APQD$ is 20 cm^2 .

Calculate the values of f and g .
You must show all your working.

[5]

.....

.....

.....

.....

.....

.....

.....

.....

.....

.....

.....

.....

.....

.....

.....

.....

.....

.....

.....

.....

END OF PAPER



