

Write your name here

Surname

MODEL ANSWERS

Other names

Pearson Edexcel
Level 1 / Level 2
GCSE (9–1)

Centre Number

--	--	--	--	--

Candidate Number

--	--	--	--

Mathematics

Paper 3 (Calculator)

Higher Tier

Tuesday 13 June 2017 – Morning

Time: 1 hour 30 minutes

Paper Reference

1MA1/3H

You must have: Ruler graduated in centimetres and millimetres, protractor, pair of compasses, pen, HB pencil, eraser, calculator. Tracing paper may be used.

Total Marks

Instructions

- Use **black** ink or ball-point pen.
- **Fill in the boxes** at the top of this page with your name, centre number and candidate number.
- Answer **all** questions.
- Answer the questions in the spaces provided – *there may be more space than you need.*
- You must **show all your working**.
- Diagrams are **NOT** accurately drawn, unless otherwise indicated.
- **Calculators may be used.**
- If your calculator does not have a π button, take the value of π to be 3.142 unless the question instructs otherwise.



Information

- The total mark for this paper is 80
- The marks for **each** question are shown in brackets – *use this as a guide as to how much time to spend on each question.*

Advice

- Read each question carefully before you start to answer it.
- Keep an eye on the time.
- Try to answer every question.
- Check your answers if you have time at the end.

Turn over ►

P50549A

©2017 Pearson Education Ltd.

6/6/6/6/7/4/



Pearson

Answer ALL questions.

Write your answers in the spaces provided.

You must write down all the stages in your working.

- 1 $\mathcal{E} = \{\text{odd numbers less than } 30\}$
 $A = \{3, 9, 15, 21, 27\}$
 $B = \{5, 15, 25\}$

(a) Complete the Venn diagram to represent this information.

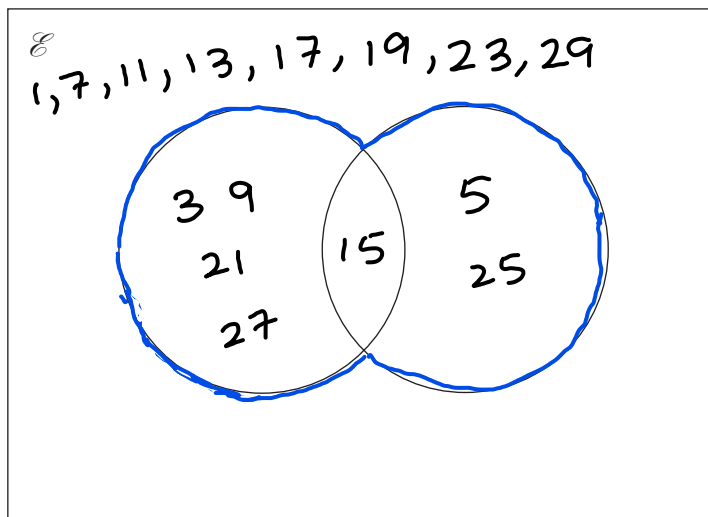

(4)

A number is chosen at random from the universal set, \mathcal{E} .

(b) What is the probability that the number is in the set $A \cup B$?

Total = 15 numbers

$A \cup B$ means A union B.

Includes all numbers in A and B
 (as outlined in blue).
 ✓ in the diagram

$$\frac{7}{15}$$

(2)

(Total for Question 1 is 6 marks)

DO NOT WRITE IN THIS AREA

DO NOT WRITE IN THIS AREA

DO NOT WRITE IN THIS AREA



2 Solve the simultaneous equations

$$\begin{aligned} 3x + y &= -4 && \textcircled{1} \\ 3x - 4y &= 6 && \textcircled{2} \end{aligned}$$

$$\begin{aligned} \textcircled{1} - \textcircled{2} & \quad 3x + y = -4 \\ & - 3x - 4y = 6 \\ \hline & y - (-4y) = -4 - 6 \\ & y + 4y = -10 \\ & 5y = -10 \\ & y = -2 \end{aligned}$$

Subs. $y = -2$ in $\textcircled{1}$

$$\begin{aligned} 3x + (-2) &= -4 \\ 3x - 2 &= -4 && \textcircled{+2} \\ 3x &= -2 && \textcircled{\div 3} \\ x &= \frac{-2}{3} \end{aligned}$$

$$\begin{aligned} x &= \dots\dots\dots \frac{-2}{3} \\ y &= \dots\dots\dots -2 \end{aligned}$$

(Total for Question 2 is 3 marks)



3 The table shows some information about the dress sizes of 25 women.

Dress size	Number of women	Cumulative
8	2	2
10	9	11
12	8	19
14	6	25

(a) Find the median dress size.

$$\text{Total women} = 2 + 9 + 8 + 6 = 25$$

$$\text{Median} = \frac{n+1}{2} \text{th} = \frac{25+1}{2} = 13\text{th woman}$$

The 13th woman falls in size 2

12
(1)

3 of the 25 women have a shoe size of 7

Zoe says that if you choose at random one of the 25 women, the probability that she has either a shoe size of 7 or a dress size of 14 is $\frac{9}{25}$ because

$$\frac{3}{25} + \frac{6}{25} = \frac{9}{25}$$

(b) Is Zoe correct?

You must give a reason for your answer.

Zoe is incorrect because shoe size and cloths size are not mutually exclusive.

i.e: A woman can be both size 14 & have size 7 feet. (1)

(Total for Question 3 is 2 marks)

DO NOT WRITE IN THIS AREA

DO NOT WRITE IN THIS AREA

DO NOT WRITE IN THIS AREA



- 4 Daniel bakes 420 cakes.
He bakes only vanilla cakes, banana cakes, lemon cakes and chocolate cakes.

$\frac{2}{7}$ of the cakes are vanilla cakes.

35% of the cakes are banana cakes.

The ratio of the number of lemon cakes to the number of chocolate cakes is 4:5

Work out the number of lemon cakes Daniel bakes.

$$\text{Vanilla} = \frac{2}{7} \times 420 = 120$$

$$\text{Banana} = \frac{35}{100} \times 420 = 147$$

$$\begin{aligned} \therefore \text{Lemon or Chocolate} &= 420 - (120 + 147) \\ &= 420 - 267 = 153 \end{aligned}$$

Lemon : chocolate

$$\begin{array}{l} 4 : 5 \quad \left. \vphantom{4 : 5} \right\} \\ \underbrace{\hspace{1.5cm}} \quad \left. \vphantom{4 : 5} \right\} \end{array} \quad \frac{153}{4+5} \times 4 = 68 \text{ Lemon cakes}$$

Total Parts

Lemon cakes ratio

68

(Total for Question 4 is 5 marks)



5 In the diagram, AB , BC and CD are three sides of a regular polygon P .

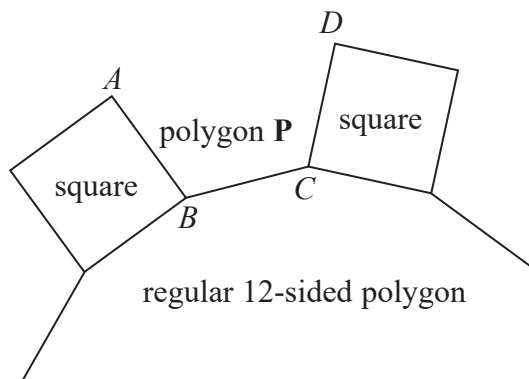

Show that polygon P is a hexagon.
You must show your working.

$$\begin{aligned} \Sigma \text{Interior angle of} &= (12-2) 180 \\ \text{12-sided polygon} &= 10 \times 180 = 1800^\circ \end{aligned}$$

$$\text{One interior angle of 12-sided polygon} = \frac{1800}{12} = 150^\circ$$

$$\begin{aligned} \text{Size of Interior angle of polygon P.} &= 360^\circ - 150^\circ - 90^\circ \\ &= 120^\circ \end{aligned}$$

90° is the interior angle of a square.

$$120 \times \text{no. of sides of polygon P} = (\text{no. of sides} - 2) \times 180$$

$$\frac{2}{3} \times \text{no. of sides} = \text{no. of sides} - 2 \quad \leftarrow \div 180$$

$$2 = \left(1 - \frac{2}{3}\right) \text{no. of sides}$$

$$2 = \frac{1}{3} \times \text{no. of sides}$$

$$\begin{aligned} \text{no. of sides} &= 2 \times 3 \\ &= 6 \text{ sides is} \\ &= \text{hexagon} \end{aligned}$$

(Total for Question 5 is 4 marks)

DO NOT WRITE IN THIS AREA

DO NOT WRITE IN THIS AREA

DO NOT WRITE IN THIS AREA



6 The density of apple juice is 1.05 grams per cm^3 .

The density of fruit syrup is 1.4 grams per cm^3 .

The density of carbonated water is 0.99 grams per cm^3 .

25 cm^3 of apple juice are mixed with 15 cm^3 of fruit syrup and 280 cm^3 of carbonated water to make a drink with a volume of 320 cm^3 .

Work out the density of the drink.

Give your answer correct to 2 decimal places.

$$\text{density} = \frac{\text{mass}}{\text{volume}}$$

$$\text{Mass of apple juice: } 1.05 \times 25 = 26.25$$

$$\text{Mass of Fruit Syrup: } 1.4 \times 15 = 21$$

$$\text{Mass of carbonated water: } 0.99 \times 280 = 277.2$$

$$\text{Total mass} = 324.45 \text{ g}$$

$$\text{density} = \frac{324.45}{320} = 1.013 \approx 1.01 \text{ g/cm}^3$$

.....1.01..... g/cm^3

(Total for Question 6 is 4 marks)



7 ABC is a right-angled triangle.

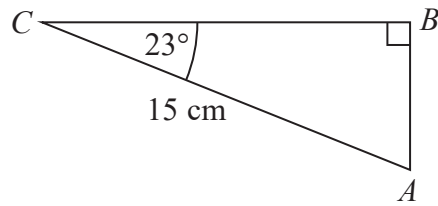

Calculate the length of AB .

Give your answer correct to 3 significant figures.

$$\sin Q = \frac{\text{opp}}{\text{hyp}}$$

$$\sin 23 = \frac{AB}{15} \quad \left. \vphantom{\sin 23} \right\} \times 15$$

$$15 \sin 23 = AB$$

$$AB = 5.8609$$

$$\approx 5.86$$

5.86

.....cm

(Total for Question 7 is 2 marks)

DO NOT WRITE IN THIS AREA

DO NOT WRITE IN THIS AREA

DO NOT WRITE IN THIS AREA



- 8 A square, with sides of length x cm, is inside a circle.
Each vertex of the square is on the circumference of the circle.

The area of the circle is 49 cm^2 .

Work out the value of x .

Give your answer correct to 3 significant figures.

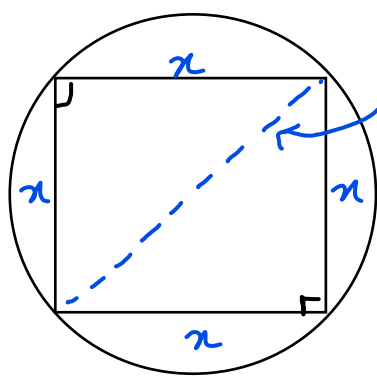

Angle subtended at the circumference by a semicircle is 90° .

Area of a circle $= \pi r^2$

$$\pi r^2 = 49$$

$$r^2 = \frac{49}{\pi}$$

$$r = \sqrt{\frac{49}{\pi}}$$

Pythagorean theorem

$$a^2 + b^2 = c^2$$

$$x^2 + x^2 = \left(2 \times \sqrt{\frac{49}{\pi}}\right)^2$$

$$2x^2 = 4 \times \frac{49}{\pi}$$

$$2x^2 = \frac{196}{\pi}$$

$$x^2 = \frac{196}{2\pi}$$

$$x = 5.585$$

5.59

(Total for Question 8 is 4 marks)



- 9 The box plot shows information about the distribution of the amounts of money spent by some male students on their holidays.

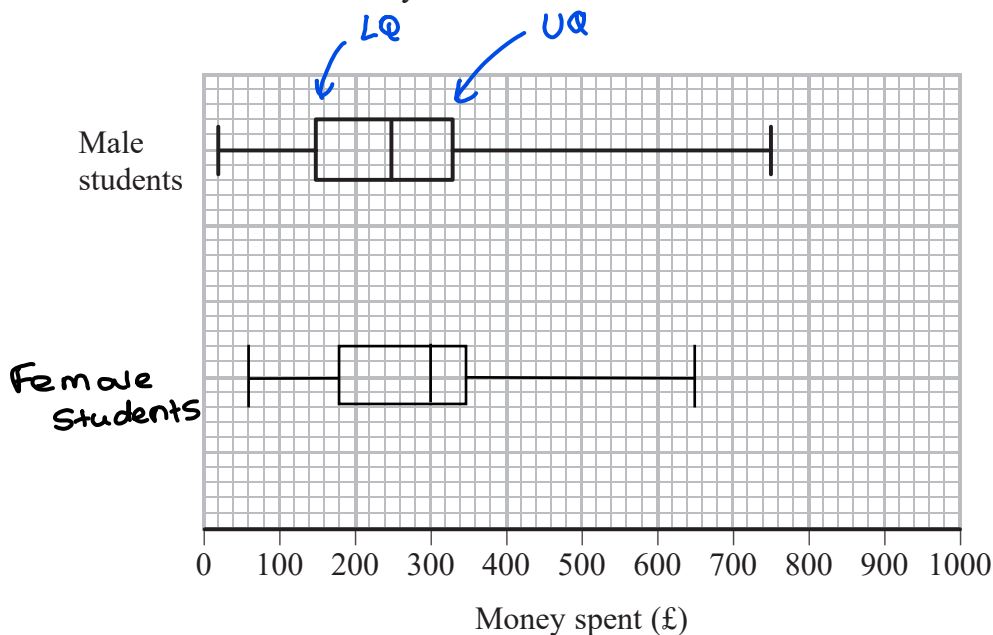

- (a) Work out the interquartile range for the amounts of money spent by these male students.

$$\begin{aligned}
 \text{IQR} &= 330 - 150 \\
 &= 180
 \end{aligned}$$

IQR = upper quartile - Lower quartile.

£ 180 (2)

The table below shows information about the distribution of the amounts of money spent by some female students on their holidays.

	Smallest	Lower quartile	Median	Upper quartile	Largest
Money spent (£)	60	180	300	350	650

- (b) On the grid above, draw a box plot for the information in the table. (2)



Chris says,

“The box plots show that the female students spent more money than the male students.”

(c) Is Chris correct?

Give a reason for your answer.

Yes, because Females have a greater median of 300 compared to that of males (250).

(1)

(Total for Question 9 is 5 marks)

10 Naoby invests £6000 for 5 years.

The investment gets compound interest of $x\%$ per annum.

At the end of 5 years the investment is worth £8029.35

Work out the value of x .

$$r = 1 + \frac{x}{100}$$

$$6000 \times r^5 = 8029.35$$

$\div 6000$ (indicated by a blue arrow)

$$r^5 = \frac{8029.35}{6000}$$

$$r^5 = 1.34$$

$\sqrt[5]{}$ (indicated by a blue arrow)

$$r = \sqrt[5]{1.34} = 1.06$$

$$1.06 = 1 + \frac{x}{100} \Rightarrow \frac{x}{100} = 0.06 \Rightarrow x = 6\%$$

6%

(Total for Question 10 is 3 marks)



11 Jeff is choosing a shrub and a rose tree for his garden.
At the garden centre there are 17 different types of shrubs and some rose trees.

Jeff says,

“There are 215 different ways to choose one shrub and one rose tree.”

Could Jeff be correct?

You must show how you get your answer.

$$\text{No. of rose trees} = 215 \div 17 = 12.6$$

12.6 is not a whole number. The no. of rose trees has to be a whole number
eg: 12 or 13.

\therefore No, Jeff is wrong.

(Total for Question 11 is 2 marks)

12 The points A, B, C and D lie in order on a straight line.

$$AB:BD = 1:5 \quad \textcircled{1}$$

$$AC:CD = 7:11 \quad \textcircled{2}$$

Work out $AB:BC:CD$

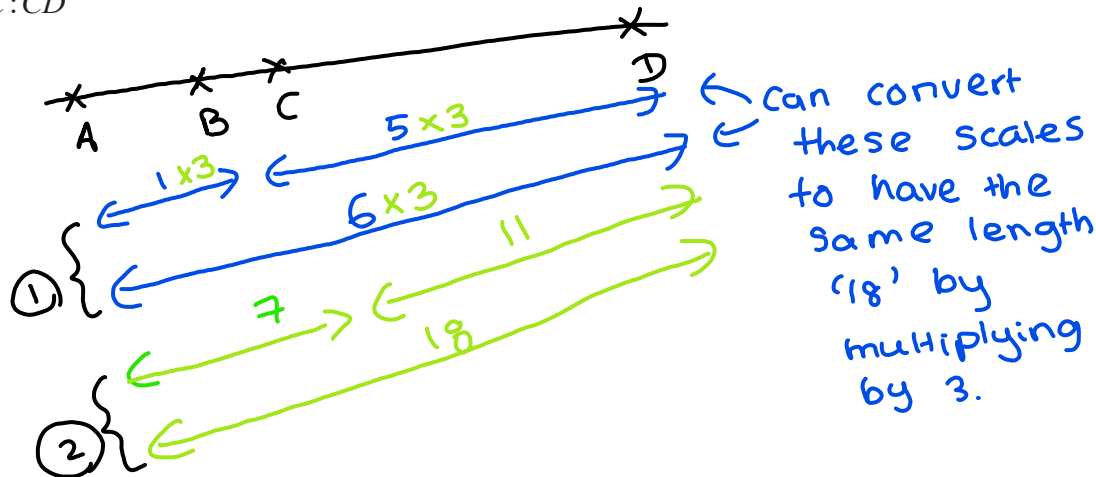

\therefore Now

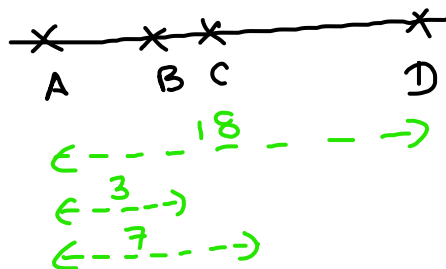

$$\begin{aligned} AB &= 3 \\ BC &= AC - AB \\ &= 7 - 3 \\ &= 4 \\ CD &= AD - AC \\ &= 18 - 7 = 11 \end{aligned}$$

$$3 : 4 : 11$$

(Total for Question 12 is 3 marks)

DO NOT WRITE IN THIS AREA

DO NOT WRITE IN THIS AREA

DO NOT WRITE IN THIS AREA



13

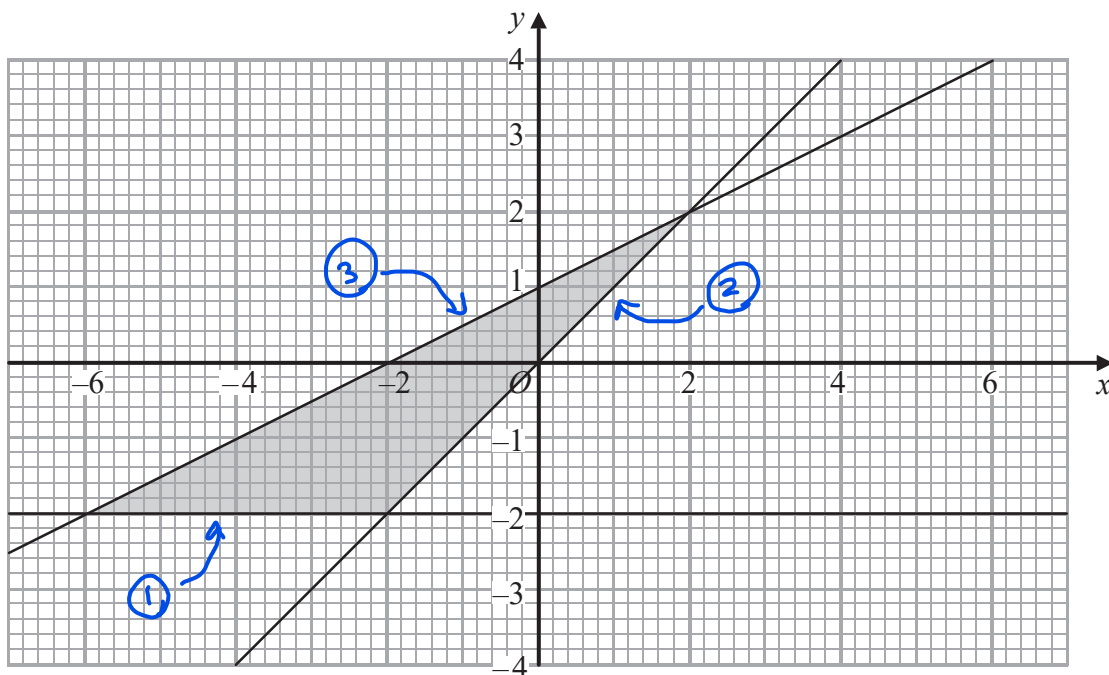

Write down the three inequalities that define the shaded region.

① $y = -2$

② $y = x$

③ $m = \frac{y_2 - y_1}{x_2 - x_1} = \frac{4 - (-2)}{6 - (-6)} = \frac{4 + 2}{6 + 6} = \frac{6}{12} = \frac{1}{2}$

$y = mx + c$

$y = \frac{1}{2}x + 1$

Subs.
 $m = \frac{1}{2}$
 $c = 1$

Solid line means greater/less than or equal to.

Find a point within the region and subs. into equations to determine greater or less than

$\left. \begin{array}{l} y \geq -2 \\ y \geq x \\ y \leq \frac{1}{2}x + 1 \end{array} \right\}$

(Total for Question 13 is 4 marks)

DO NOT WRITE IN THIS AREA



14 (a) Simplify $\frac{x^2 - 16}{2x^2 - 5x - 12}$

$$\frac{(x+4)(x-4)}{2x^2 - 8x + 3x - 12} = \frac{(x+4)(x-4)}{2x(x-4) + 3(x-4)} = \frac{(x+4)\cancel{(x-4)}}{\cancel{(x-4)}(2x+3)}$$

$$= \frac{x+4}{2x+3}$$

$$\frac{x+4}{2x+3}$$

(3)

(b) Make v the subject of the formula $w = \frac{15(t - 2v)}{v}$

$$w = \frac{15t - 30v}{v} \quad \text{Expand out brackets}$$

$$\begin{matrix} \times v \downarrow \\ wv = 15t - 30v \end{matrix}$$

$$\begin{matrix} +30v \downarrow \\ wv + 30v = 15t \end{matrix}$$

$$v(w+30) = 15t \quad \text{Take out a factor of } v.$$

$$\begin{matrix} \div w+30 \downarrow \\ v = \frac{15t}{w+30} \end{matrix}$$

$$\frac{15t}{w+30}$$

(3)

(Total for Question 14 is 6 marks)

DO NOT WRITE IN THIS AREA

DO NOT WRITE IN THIS AREA

DO NOT WRITE IN THIS AREA



15

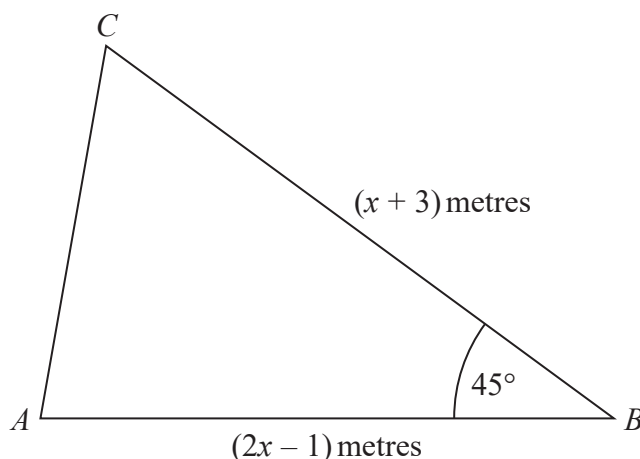

The area of triangle ABC is $6\sqrt{2} \text{ m}^2$.

Calculate the value of x .

Give your answer correct to 3 significant figures.

$$\text{Area} = \frac{1}{2} \times a \times b \times \sin C$$

$$6\sqrt{2} = \frac{1}{2} \times (x+3) \times (2x-1) \times \sin(45)$$

$$6\sqrt{2} = \frac{\sqrt{2}}{4} (x+3)(2x-1)$$

$$\times \frac{4}{\sqrt{2}} \rightarrow 24 = (x+3)(2x-1) \quad \text{Expand}$$

$$24 = 2x^2 - x + 6x - 3 \quad \text{collect like terms}$$

$$-24 \rightarrow 0 = 2x^2 + 5x - 27$$

$$x = \frac{-b \pm \sqrt{b^2 - 4ac}}{2a}$$

$$= \frac{-5 \pm \sqrt{5^2 - 4(2)(-27)}}{2(2)}$$

$$= 2.63 \text{ m OR } -5.13 \text{ m}$$

Reject as lengths are not negative.

.....
2.63m

(Total for Question 15 is 5 marks)



17 A train travelled along a track in 110 minutes, correct to the nearest 5 minutes.

Jake finds out that the track is 270 km long.

He assumes that the track has been measured correct to the nearest 10 km.

- (a) Could the average speed of the train have been greater than 160 km/h?
You must show how you get your answer.

Upper bound of track length = 275 km

Lower bound of time = 107.5 min

= $\frac{107.5}{60}$ hrs = $\frac{43}{24}$ hours

greatest speed = $\frac{\text{greatest distance}}{\text{shortest time}}$

Speed = $\frac{\text{distance}}{\text{time}} = \frac{275}{\left(\frac{43}{24}\right)} \approx 153.4 \times 153 \text{ km/h}$

∴ The avg speed cannot have been greater than 160 km/h as the greatest speed is 153 km/h. (4)

Jake's assumption was wrong.

The track was measured correct to the nearest 5 km.

- (b) Explain how this could affect your decision in part (a).

The higher bound for distance is less, so max avg. speed is lower.

(1)

(Total for Question 17 is 5 marks)

DO NOT WRITE IN THIS AREA

DO NOT WRITE IN THIS AREA

DO NOT WRITE IN THIS AREA



18

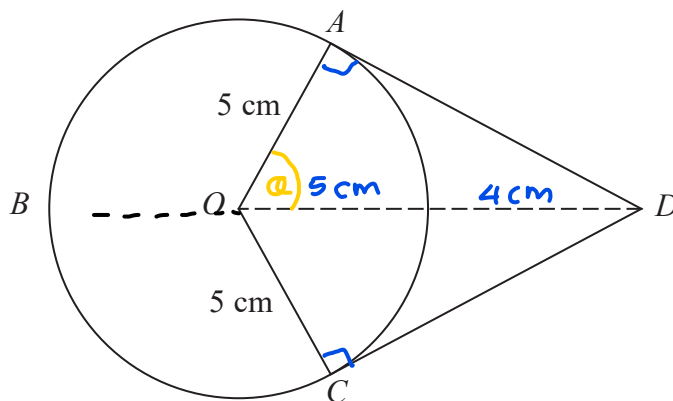

A, B and C are points on a circle of radius 5 cm, centre O .
 DA and DC are tangents to the circle.
 $DO = 9$ cm

Work out the length of arc ABC .
 Give your answer correct to 3 significant figures.

$$\cos \theta = \frac{\text{Adj}}{\text{Hyp}} \quad \theta = \cos^{-1} \left(\frac{5}{9} \right)$$

$$= \frac{5}{9} \quad = 56.3^\circ$$

$$\hat{A}OB = 180 - 56.3$$

$$= 123.7^\circ$$

x circumference of a sector $\frac{\theta}{360} \times 2 \times \pi \times r$

$$\hat{A}OB = \hat{C}OB \quad ABC = \frac{2 \times 123.7}{360} \times 2 \times \pi \times 5 = 21.6 \text{ cm}$$

..... 21.6 cm

(Total for Question 18 is 5 marks)

DO NOT WRITE IN THIS AREA

DO NOT WRITE IN THIS AREA

DO NOT WRITE IN THIS AREA



19 Solve $2x^2 + 3x - 2 > 0$

$$2x^2 + 3x - 2 = 0$$

$$2x^2 + 4x - x - 2 = 0$$

$$2x(x+2) - 1(x+2) = 0$$

$$(x+2)(2x-1) = 0$$

$$x+2=0 \quad 2x-1=0$$

$$x = -2 \quad x = \frac{1}{2}$$

Shade areas where $y > 0$

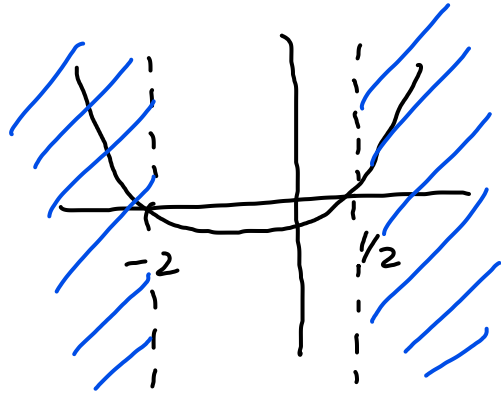

$$x < -2, \quad x > \frac{1}{2}$$

(Total for Question 19 is 3 marks)

DO NOT WRITE IN THIS AREA

DO NOT WRITE IN THIS AREA

DO NOT WRITE IN THIS AREA



20 The equation of a curve is $y = a^x$
 A is the point where the curve intersects the y-axis.

(a) State the coordinates of A.

$$y = a^x$$

when curve intersect y-axis, $x = 0$

$$y = a^0 \quad x^0 = 1$$

$$y = 1$$

$$\left(\dots\dots\dots 0 \dots\dots\dots, \dots\dots\dots 1 \dots\dots\dots \right)$$

(1)

The equation of circle C is $x^2 + y^2 = 16$

The circle C is translated by the vector $\begin{pmatrix} 3 \\ 0 \end{pmatrix}$ to give circle B.

(b) Draw a sketch of circle B.

Label with coordinates
 the centre of circle B
 and any points of intersection with the x-axis.

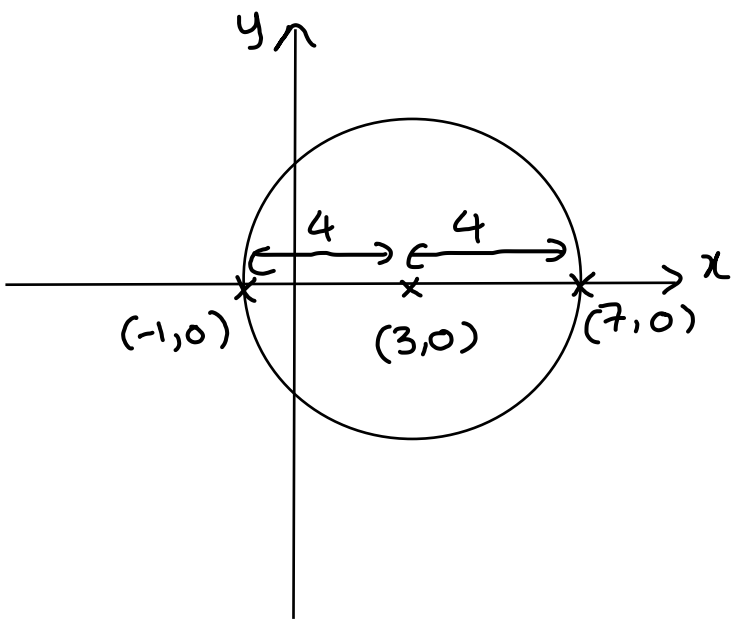

(3)

(Total for Question 20 is 4 marks)

TOTAL FOR PAPER IS 80 MARKS



DO NOT WRITE IN THIS AREA