



Please write clearly in block capitals.

Centre number

--	--	--	--	--

Candidate number

--	--	--	--

Surname

---

Forename(s)

---

Candidate signature

---

# GCSE MATHEMATICS (LINEAR)

# F

Foundation Tier Paper 1

Thursday 26 May 2016

Morning

Time allowed: 1 hour 15 minutes

## Materials

For this paper you must have:

- mathematical instruments.

You must **not** use a calculator.



## Instructions

- Use black ink or black ball-point pen. Draw diagrams in pencil.
- Answer **all** questions.
- You must answer the questions in the spaces provided. Do not write outside the box around each page or on blank pages.
- Do all rough work in this book.

## Information

- The marks for questions are shown in brackets.
- The maximum mark for this paper is 70.
- The quality of your written communication is specifically assessed in Questions 10 and 12. These questions are indicated with an asterisk (\*).
- You may ask for more answer paper, tracing paper and graph paper. These must be tagged securely to this answer book.

## Advice

- In all calculations, show clearly how you work out your answer.



J U N 1 6 4 3 6 5 1 F 0 1

WMP/Jun16/E5

**4365/1F**

**Formulae Sheet: Foundation Tier**

**Area of trapezium** =  $\frac{1}{2}(a+b)h$

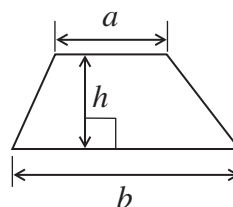

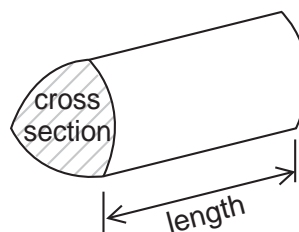

**Volume of prism** = area of cross section  $\times$  length

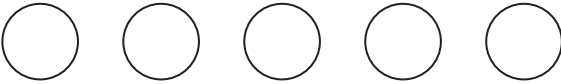

Answer **all** questions in the spaces provided.

- 1** 60 people were asked the colour of their car.  
The pictogram shows the results.  
The information for Silver is missing.

		Frequency
Red		20
Black		
Silver		
Blue		

**Key**  Represents \_\_\_\_\_ cars

- 1 (a)** 20 cars are Red.  
Complete the key.

[1 mark]

- 1 (b)** Complete the pictogram and the frequency column.

[3 marks]

---



---

4
---

Turn over ►



2 Here is part of the menu in a café.

Drinks	
Tea	£1.20
Coffee	£1.60
Cola	£1.50

Snacks	
Biscuit	65p
Scone	£1.00
Donut	95p

2 (a) Martyn buys one drink and one snack.  
He pays **less** than £2

What drink and snack did he buy?

[1 mark]

---

Answer \_\_\_\_\_ and \_\_\_\_\_

2 (b) Sue buys two teas, one biscuit and one scone.  
She pays with a £5 note.  
She gets 4 coins in her change.

Work out the coins that she gets.

[3 marks]

---



---



---



---



---

Answer \_\_\_\_\_, \_\_\_\_\_, \_\_\_\_\_, \_\_\_\_\_



2 (c) The café has a breakfast deal.

**Breakfast deal**  
Coffee and muffin  
Only £2.25

The breakfast deal is 50p cheaper than the normal price.

Work out the normal price of a muffin.

**[3 marks]**

---

---

---

---

---

---

---

Answer £ \_\_\_\_\_

**Turn over for the next question**

7

**Turn over ►**



**3 (a)** Here is a square grid.

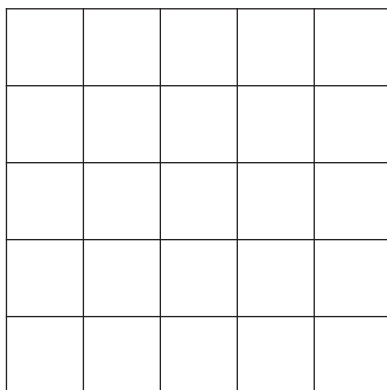

Shade 40% of the grid.

**[1 mark]**

**3 (b)** Here is another square grid.

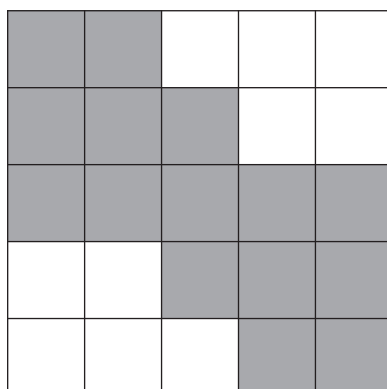

What fraction of this grid is shaded?  
Give your answer in its simplest form.

**[2 marks]**

---

---

Answer \_\_\_\_\_



**4 (a)** Work out  $383 + 419$

**[1 mark]**

Answer \_\_\_\_\_

**4 (b)** Work out  $522 \div 6$

**[1 mark]**

Answer \_\_\_\_\_

**4 (c)** Work out  $52 \times 36$

**[3 marks]**

Answer \_\_\_\_\_



5 (a) Work out the value of  $7a - 4b$  when  $a = 3$  and  $b = -2$

[2 marks]

---

---

---

Answer \_\_\_\_\_

5 (b) Solve  $8x = 96$

[1 mark]

---

$x =$  \_\_\_\_\_

5 (c) Solve  $y + 12 = 28$

[1 mark]

---

$y =$  \_\_\_\_\_





**6** Here is a school timetable for one morning.

Not drawn  
accurately

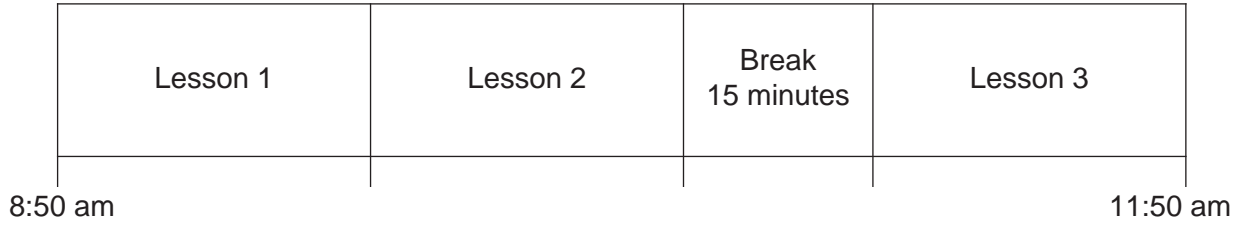

Each lesson is the same length.  
Between lessons 2 and 3 there is a 15 minute break.

Work out the length of one lesson.

**[3 marks]**

---

---

---

---

Answer \_\_\_\_\_ minutes

**Turn over for the next question**

7

**Turn over ►**



- 7 Here is triangle  $ABC$ .  
It is drawn accurately.

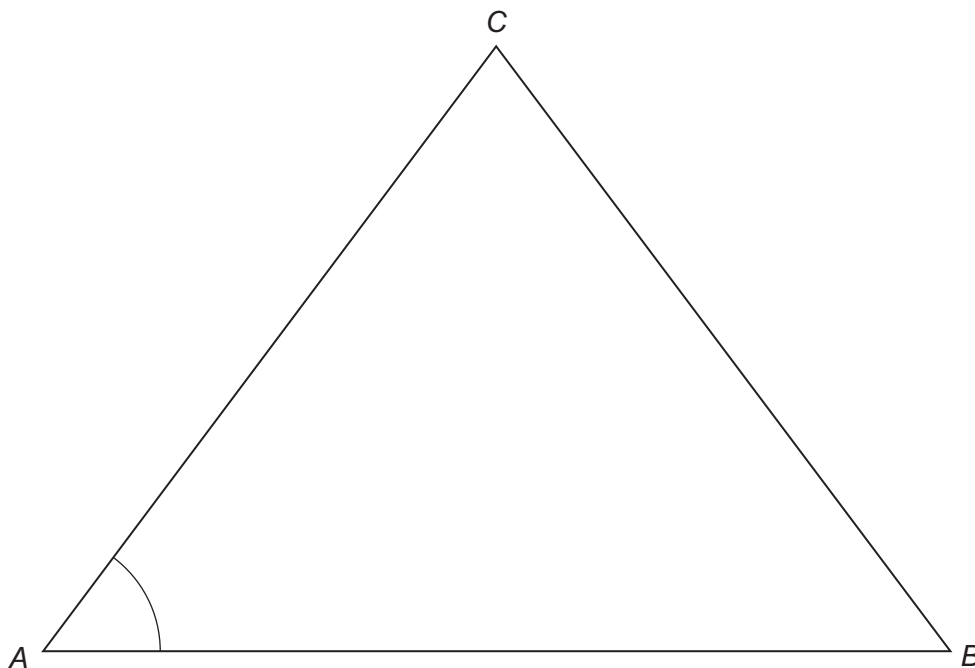

- 7 (a) Measure angle  $CAB$ .

[1 mark]

Answer \_\_\_\_\_ degrees

- 7 (b) Work out the area of the triangle.  
Show clearly any measurements that you make.

[3 marks]

---

---

---

Answer \_\_\_\_\_  $\text{cm}^2$



8 (a) Circle the expression that is the same as six less than  $x$ .

[1 mark]

$6 - x$

$6x$

$\frac{x}{6}$

$x - 6$

8 (b) Circle the expression that is the same as one-quarter of  $y$ .

[1 mark]

$y \div 0.4$

$\frac{4}{y}$

$\frac{y}{4}$

$4y$

8 (c) Write the output of this number machine as an expression.

[1 mark]

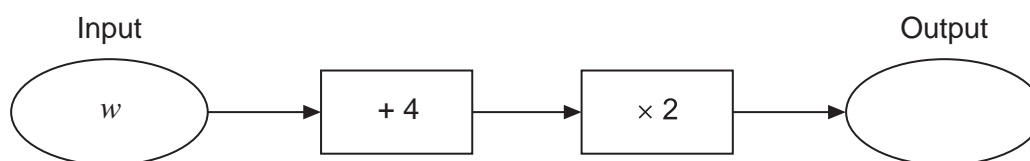

Answer \_\_\_\_\_

7
---

Turn over ►



**9 (a)** Work out  $\frac{7}{10} - \frac{2}{5}$

**[2 marks]**

---

---

---

Answer \_\_\_\_\_

**9 (b)** Work out  $\frac{2}{3}$  of 36

**[1 mark]**

---

---

Answer \_\_\_\_\_



**\*10** $AB$  is a straight line.

Work out the size of angle  $a$ .  
Give a reason for your answer.

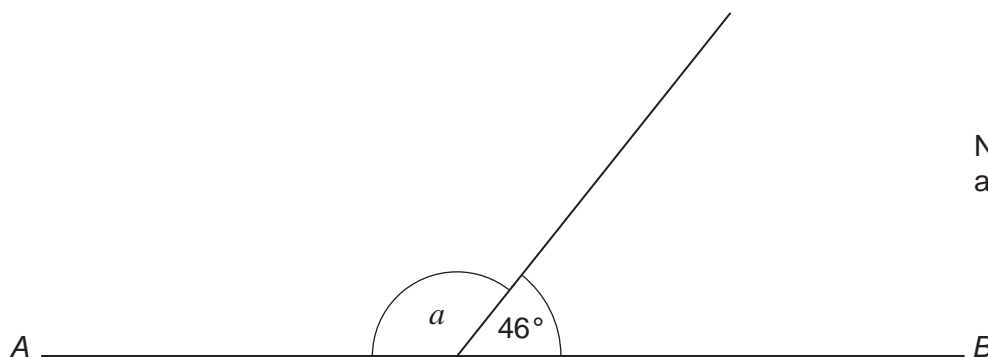
**[2 marks]**Not drawn  
accurately

Answer \_\_\_\_\_ degrees

Reason \_\_\_\_\_  
\_\_\_\_\_**Turn over for the next question**

- 11 (a)** How many pounds are in 1 kilogram?  
Circle the closest estimate.

[1 mark]

1.6

2.2

2.5

4.5

- 11 (b)** How many kilometres are in 1 mile?  
Circle the closest estimate.

[1 mark]

0.625

1.6

2.5

5

- 11 (c)** Here is a conversion graph.

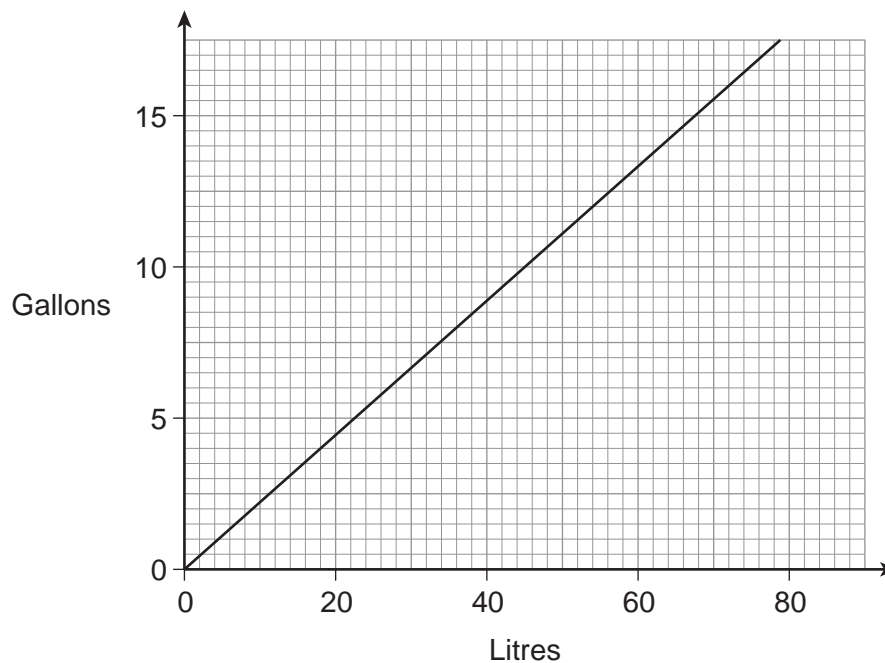

Convert 30 gallons to litres.

[2 marks]

---



---

Answer \_\_\_\_\_ litres



**\*12**

Increase £190 by 35%

**[3 marks]**

---

---

---

---

---

---

---

---

Answer £ \_\_\_\_\_

**Turn over for the next question**

**7**

**Turn over ►**



**13** Six balls just fit inside a box as shown.

The balls each have a diameter of 5 cm  
The box is a cuboid.

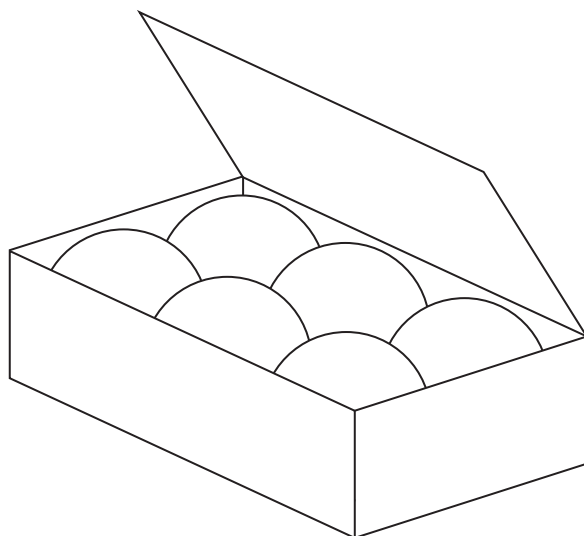

Work out the volume of the box.

**[3 marks]**

---

---

---

---

---

---

---

---

---

---

Answer \_\_\_\_\_  $\text{cm}^3$





14 Two 10 cm by 6 cm rectangles are cut in half as shown.

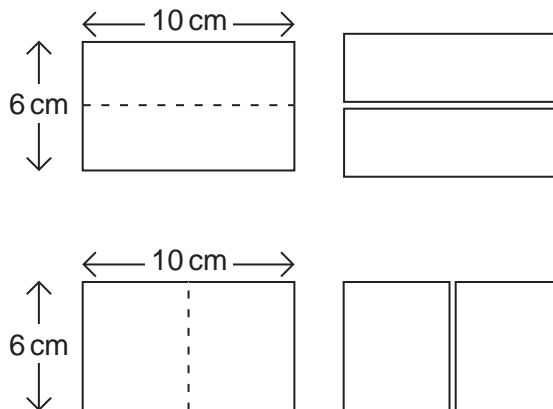

Not drawn  
accurately

The four pieces are joined together, without overlap, as shown.

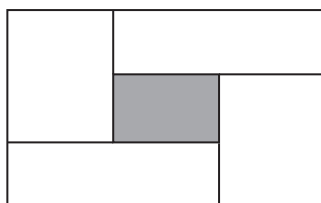

Not drawn  
accurately

Work out the perimeter of the shaded rectangle.

[3 marks]

---

---

---

---

---

---

---

---

Answer \_\_\_\_\_ cm

6

Turn over ►



- 15** A bag has only red, white, blue and yellow counters.  
A counter is taken from the bag at random.  
Here are some of the probabilities.

Colour	Red	White	Blue	Yellow
Probability	0.1		0.3	

- 15 (a)** The probability of taking a white counter is twice the probability of taking a yellow counter.

Complete the table.

**[2 marks]**

---



---

- 15 (b)** There are 500 counters in the bag altogether.

Complete the table.

**[2 marks]**

Colour	Red	White	Blue	Yellow	Total
Number of counters in the bag	50				500

---



---

- 15 (c)** All of the yellow counters are taken out of the bag.

Work out the probability of taking a red counter at random from the bag now.

**[2 marks]**

---



---

Answer \_\_\_\_\_



16 Work out length  $BC$ .

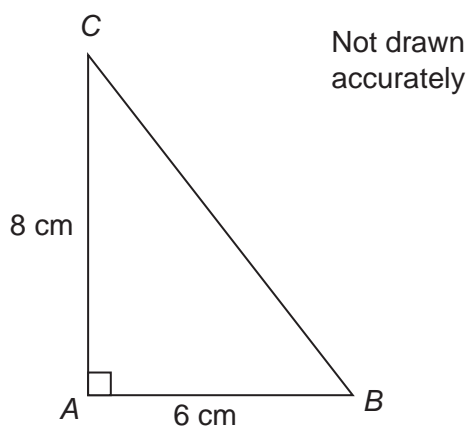

[3 marks]

---

---

---

---

Answer \_\_\_\_\_ cm

Turn over for the next question

9

Turn over ►



17 A café owner records the average monthly temperature and the monthly sales of soup over a year.

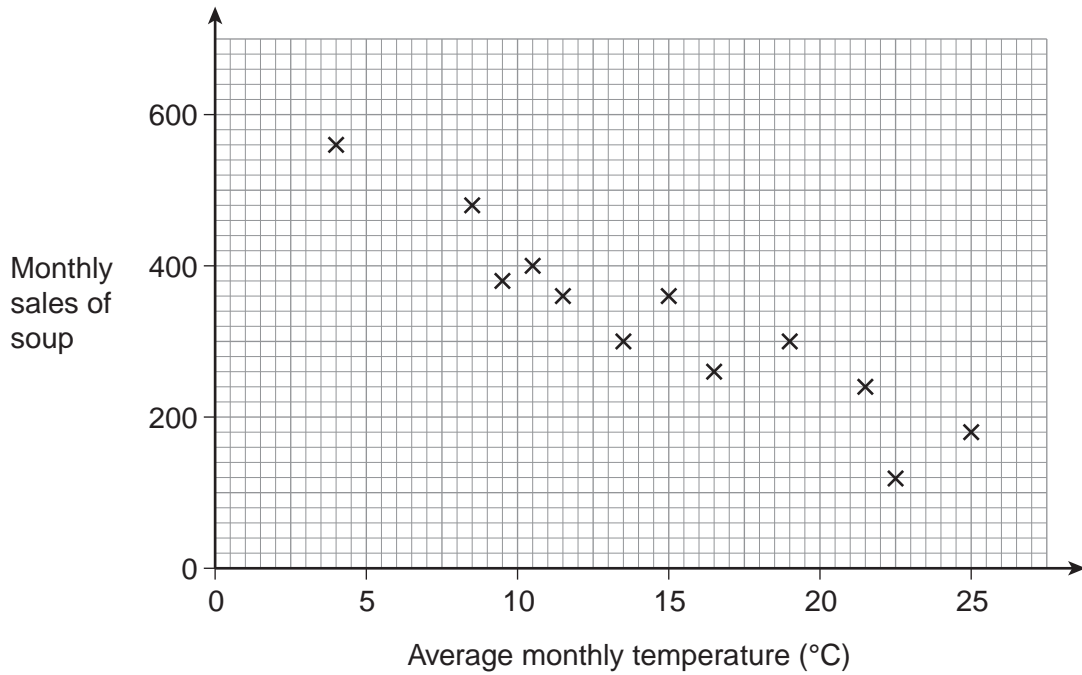

17 (a) The scatter graph shows negative correlation.

Write down the relationship between average monthly temperature and monthly sales of soup.

[1 mark]

---



---

17 (b) The average monthly temperature for the next month is predicted to be 7°C

Use the graph to estimate the sales of soup that month. You **must** show your working.

[2 marks]

---



---

Answer \_\_\_\_\_





- 19 (a) The scores on four ordinary, six-sided dice are put in order.

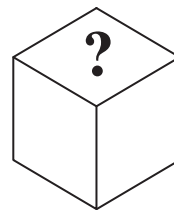
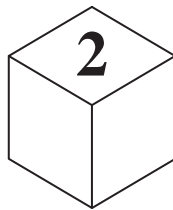
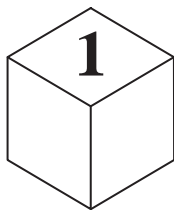
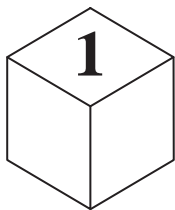

The median of the **four** scores is 0.5 **less** than the mean of the four scores.

Circle the value of the fourth score.

[1 mark]

2

3

4

5

6

- 19 (b) The dice are rolled again.  
The median of the scores is 0.5 **less** than the range.

Work out a possible set of scores.

[2 marks]

---



---



---

Answer \_\_\_\_\_, \_\_\_\_\_, \_\_\_\_\_, \_\_\_\_\_

**END OF QUESTIONS**



**There are no questions printed on this page**

**DO NOT WRITE ON THIS PAGE  
ANSWER IN THE SPACES PROVIDED**



**There are no questions printed on this page**

**DO NOT WRITE ON THIS PAGE  
ANSWER IN THE SPACES PROVIDED**

**Copyright Information**

For confidentiality purposes, from the November 2015 examination series, acknowledgements of third party copyright material will be published in a separate booklet rather than including them on the examination paper or support materials. This booklet is published after each examination series and is available for free download from [www.aqa.org.uk](http://www.aqa.org.uk) after the live examination series.

Permission to reproduce all copyright material has been applied for. In some cases, efforts to contact copyright-holders may have been unsuccessful and AQA will be happy to rectify any omissions of acknowledgements. If you have any queries please contact the Copyright Team, AQA, Stag Hill House, Guildford, GU2 7XJ.

Copyright © 2016 AQA and its licensors. All rights reserved.

