

Centre Number						Candidate Number				
Surname										
Other Names										
Candidate Signature										

For Examiner's Use	
Examiner's Initials	
Question	Mark
1	
2	
3	
4	
5	
6	
7	
8	
TOTAL	



General Certificate of Secondary Education  
Foundation Tier  
June 2013

## Science A

### Unit Chemistry C1

## CH1FP

## Chemistry

### Unit Chemistry C1

# F

Monday 10 June 2013 1.30 pm to 2.30 pm

**For this paper you must have:**

- a ruler
  - the Chemistry Data Sheet (enclosed).
- You may use a calculator.

**Time allowed**

- 1 hour

**Instructions**

- Use black ink or black ball-point pen.
- Fill in the boxes at the top of this page.
- Answer **all** questions.
- You must answer the questions in the spaces provided. Do not write outside the box around each page or on blank pages.
- Do all rough work in this book. Cross through any work you do not want to be marked.

**Information**

- The marks for questions are shown in brackets.
- The maximum mark for this paper is 60.
- You are expected to use a calculator where appropriate.
- You are reminded of the need for good English and clear presentation in your answers.
- Question 8(b) should be answered in continuous prose.  
In this question you will be marked on your ability to:
  - use good English
  - organise information clearly
  - use specialist vocabulary where appropriate.

**Advice**

- In all calculations, show clearly how you work out your answer.



J U N 1 3 C H 1 F P O 1

K94748 6/6/6

## CH1FP

Answer **all** questions in the spaces provided.

1 Magnesium burns in oxygen.



1 (a) Use the Chemistry Data Sheet to help you to answer this question.

The word equation for magnesium burning is:



Draw **one** line from each substance to its correct description.

Substance	Description
magnesium	compound
magnesium oxide	metal
oxygen	mixture
	non-metal

(3 marks)



1 (b) The diagram represents a magnesium atom.

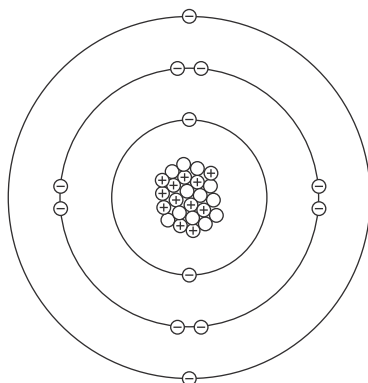

Complete the table to show the name of each particle and the charge of each particle in the magnesium atom.

Name of particle	Charge
proton	+1
neutron	.....
.....	-1

(2 marks)

1 (c) Use the Chemistry Data Sheet to help you to answer these questions.

Draw a ring around the correct answer to complete each sentence.

1 (c) (i) In a magnesium atom, the protons and neutrons are in the

core.  
nucleus.  
shell.

(1 mark)

1 (c) (ii) The number of protons in a magnesium atom is the

atomic number.  
mass number.  
group number.

(1 mark)

1 (c) (iii) The sum of the protons and neutrons in a magnesium atom is the

atomic number.  
mass number.  
group number.

(1 mark)

8

Turn over ►



- 2 Barbecues are heated by burning charcoal or burning hydrocarbons.



- 2 (a) Use the Chemistry Data Sheet to help you to answer this question.

The chemical equation for charcoal burning is:



Complete the word equation for this reaction.

carbon + .....  $\longrightarrow$  carbon dioxide

(1 mark)

- 2 (b) Propane is a hydrocarbon.

- 2 (b) (i) Complete the displayed structure of propane. Draw in the missing bonds.

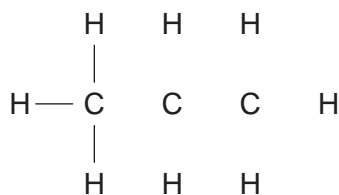

(1 mark)

- 2 (b) (ii) Write the chemical formula of propane. ....

(1 mark)



2 (b) (iii) Draw a ring around the correct answer to complete the sentence.

Propane burns in air to produce carbon dioxide and

hydrogen.

hydroxide.

water.

(1 mark)

2 (c) The table shows information about six hydrocarbons.

Hydrocarbon	State at room temperature (20 °C)	Boiling point in °C
Ethane (C <sub>2</sub> H <sub>6</sub> )	gas	-89
Ethene (C <sub>2</sub> H <sub>4</sub> )	gas	-104
Butane (C <sub>4</sub> H <sub>10</sub> )	gas	-1
Butene (C <sub>4</sub> H <sub>8</sub> )	gas	-6
Hexane (C <sub>6</sub> H <sub>14</sub> )	liquid	+69
Hexene (C <sub>6</sub> H <sub>12</sub> )	liquid	+64

Tick (✓) **two** correct statements about the six hydrocarbons.

Statement	Tick (✓)
Ethane and butane boil at temperatures less than 20 °C.	
Hexene and butene are alkanes.	
Butane and hexane are liquid at 0 °C.	
Ethene and hexene each have a carbon-carbon double bond.	

(2 marks)

Turn over ►



**3** Carbon dioxide is produced when metal carbonates are heated.

**3 (a) (i)** Draw a ring around the correct answer to complete the word equation.

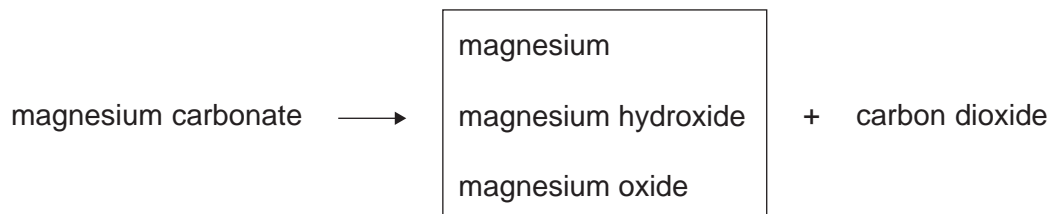

(1 mark)

**3 (a) (ii)** Draw a ring around the correct answer to complete the sentence.

The reaction to produce carbon dioxide from magnesium carbonate is

combustion.  
 decomposition.  
 fermentation.

(1 mark)

**3 (b)** A student investigated what happens when metal carbonates are heated.

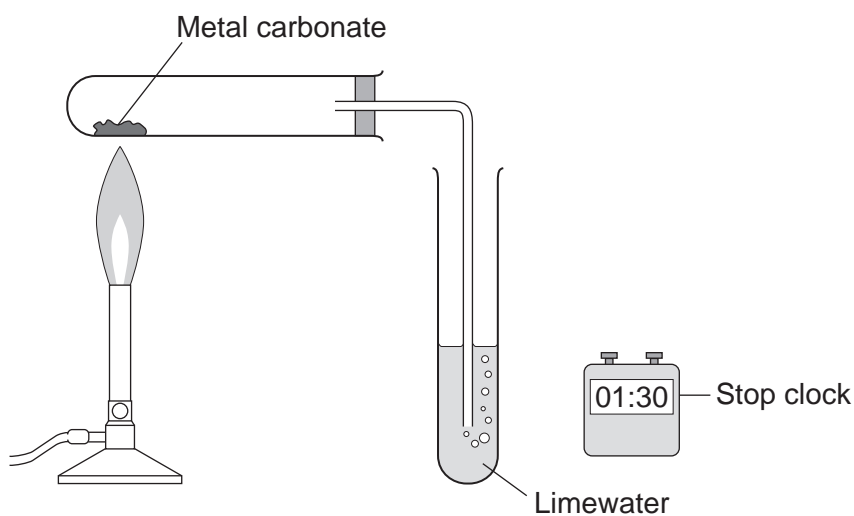

The student:

- used the apparatus to investigate heating four metal carbonates
- started the stop clock at the same time as he began to heat the metal carbonate
- stopped the stop clock when carbon dioxide was produced.



The student's results are shown in the table.

Metal carbonate	Time taken for the production of carbon dioxide to start in seconds
Calcium carbonate	163
Copper carbonate	24
Magnesium carbonate	92
Zinc carbonate	67

3 (b) (i) Tick (✓) the type of graph the student should draw from these results.

Type of graph	Tick (✓)
Bar chart	
Line graph	
Scatter graph	

(1 mark)

3 (b) (ii) Use the Chemistry Data Sheet to help you to answer this question.

Draw a ring around the correct answer to complete the sentence.

The more reactive the metal in the carbonate the 

less
more
same

 time is taken for the production of carbon dioxide to start.

(1 mark)

3 (b) (iii) How did the student know that carbon dioxide was produced?

Use the diagram of the apparatus to help you to answer this question.

.....

.....

.....

.....

(2 marks)

6
---

Turn over ►



4 Some fruits, seeds and nuts are sources of vegetable oils.

The table gives some information about three types of vegetable oil.

	<b>Corn oil</b>	<b>Olive oil</b>	<b>Rapeseed oil</b>
Saturated fat in %	14.4	14.3	6.6
Unsaturated fat in %	81.2	81.2	88.6
Melting point in °C	−18 to −5	−12 to −6	−10 to +5
Smoke point in °C	229 to 268	204 to 210	230 to 240

The smoke point is the temperature range at which the oil begins to produce smoke when heated.

4 (a) Use information from the table above to answer these questions.

4 (a) (i) Tick (✓) **one** correct reason why a vegetable oil has a range for the melting point.

<b>Reason</b>	<b>Tick (✓)</b>
A vegetable oil has a high percentage of unsaturated fat.	
A vegetable oil has a range for the smoke point.	
A vegetable oil has a mixture of fats.	

(1 mark)

4 (a) (ii) Complete the sentence.

The type of vegetable oil with the largest temperature range of smoke point is

.....

(1 mark)

4 (b) Bromine water was added drop by drop to 5 cm<sup>3</sup> of each type of vegetable oil.

4 (b) (i) Draw a ring around the correct answer to complete the sentence.

The colour of the first drop of bromine water changes from orange to

colourless.
green.
white.

(1 mark)





4 (b) (ii) Which type of vegetable oil will react with the most drops of bromine water?

Give a reason for your answer.

.....

.....

.....

.....

(2 marks)

4 (c) Potato slices can be boiled in water or fried in olive oil.

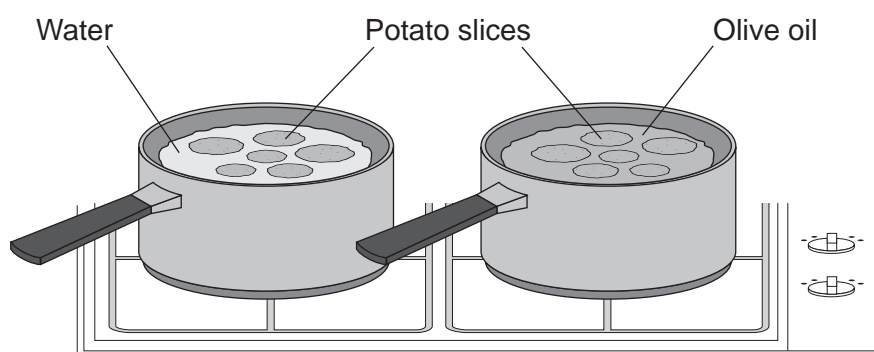

4 (c) (i) Olive oil starts to produce smoke when heated to 204 °C.  
The smoke contains carbon particles.

Suggest what happens to molecules in olive oil to produce carbon particles.

.....

.....

(1 mark)

4 (c) (ii) Potato slices boiled in water will be different from potato slices fried in olive oil.

Describe **two** differences.

.....

.....

.....

.....

(2 marks)



**There are no questions printed on this page**

**DO NOT WRITE ON THIS PAGE  
ANSWER IN THE SPACES PROVIDED**



- 5 The diagram shows a ballpoint pen.

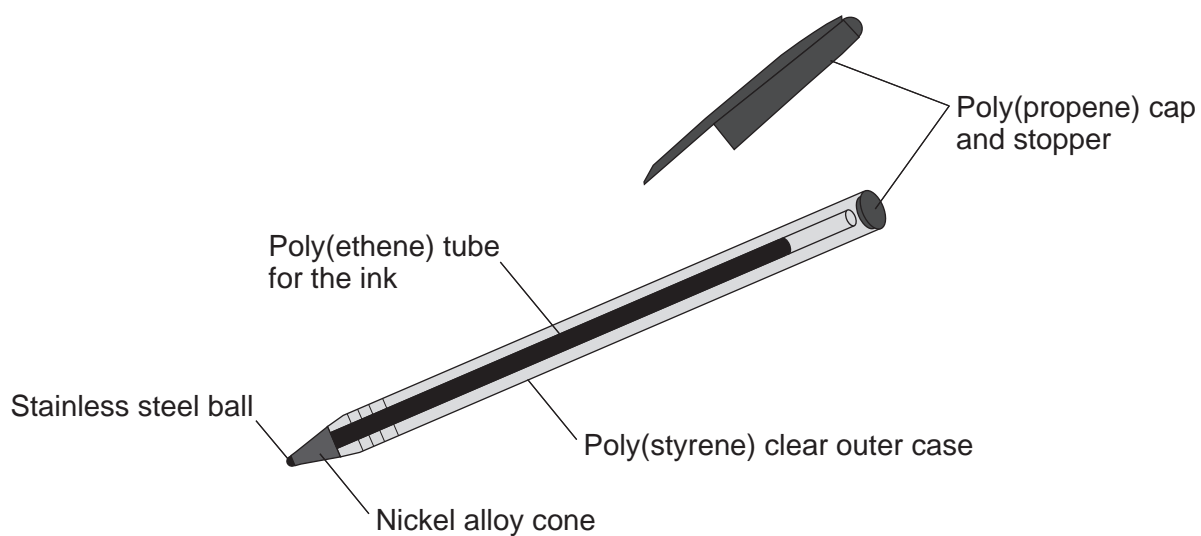

- 5 (a) Polymers are used to make the ballpoint pen.

- 5 (a) (i) Name the monomer used to make poly(ethene).

.....  
(1 mark)

- 5 (a) (ii) Draw **one** line from the monomer propene to its polymer poly(propene).

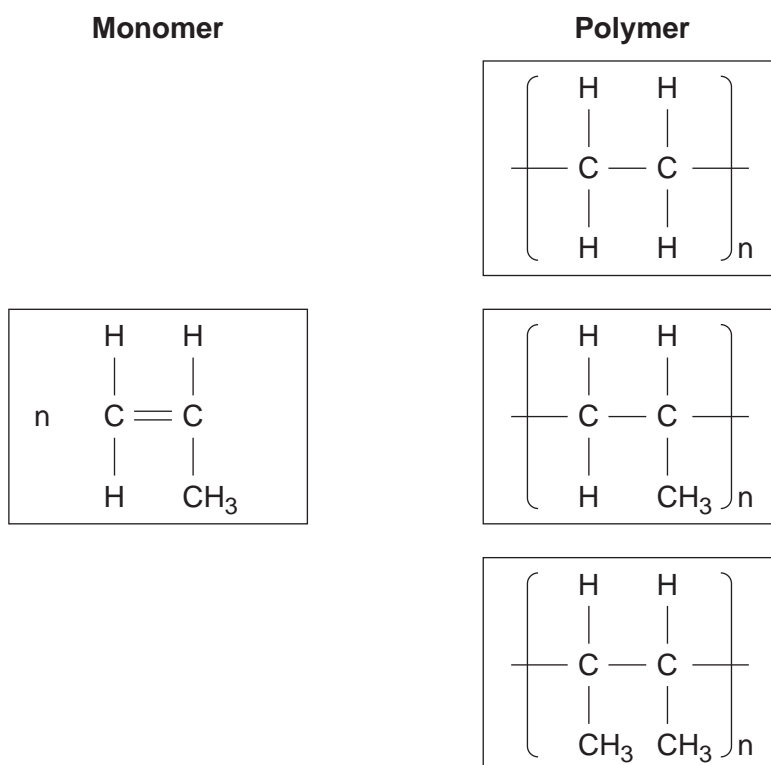

(1 mark)

Turn over ►



**5 (b)** Two alloys are used to make the ballpoint pen.

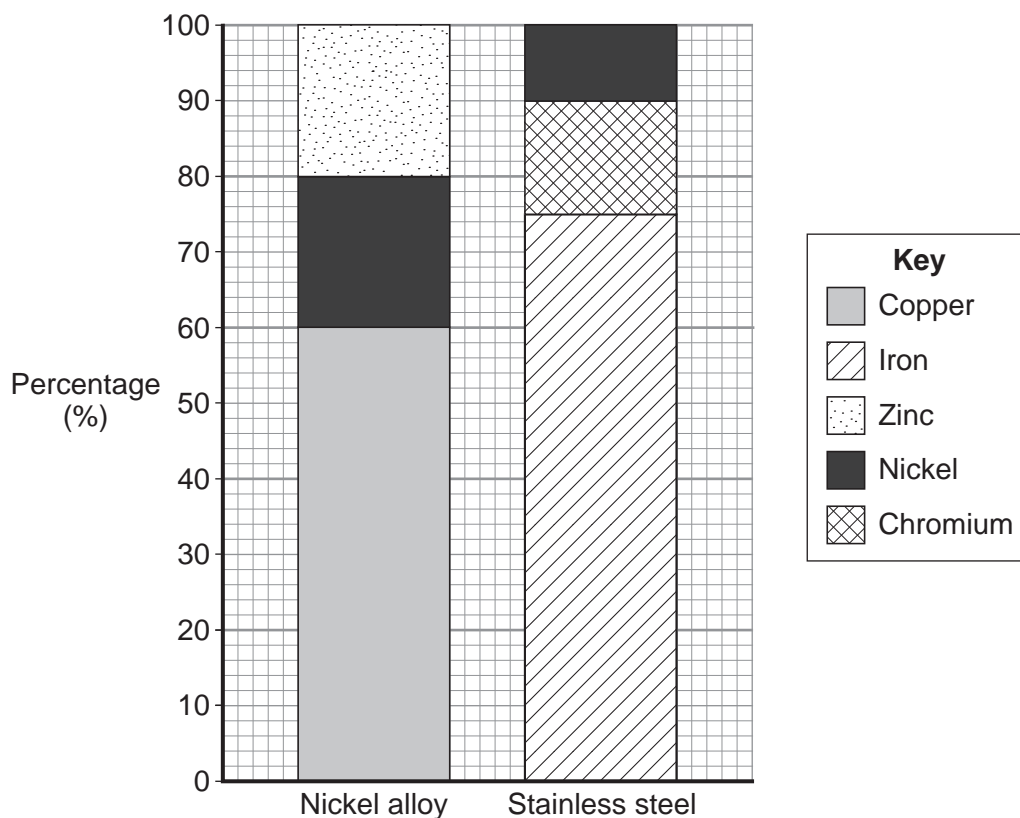

Use the bar chart to answer these questions.

**5 (b) (i)** Which metal is in both of these alloys? .....  
(1 mark)

**5 (b) (ii)** What is the percentage of iron in the stainless steel? ..... %  
(1 mark)



**5 (b) (iii)** The alloy stainless steel is used instead of pure iron for the ball of the pen.  
Give **two** reasons why.

.....

.....

.....

.....

(2 marks)

**5 (c)** Tick (✓) **one** advantage and tick (✓) **one** disadvantage of **recycling** this type of ballpoint pen.

	<b>Advantage Tick (✓)</b>	<b>Disadvantage Tick (✓)</b>
Can be refilled and reused		
Conserves resources of crude oil and ores		
High cost of separating materials		
Polymers and alloys are not expensive		

(2 marks)

8
---

**Turn over for the next question**

**Turn over ▶**



6 In 1912 Wegener suggested his theory of continental drift.

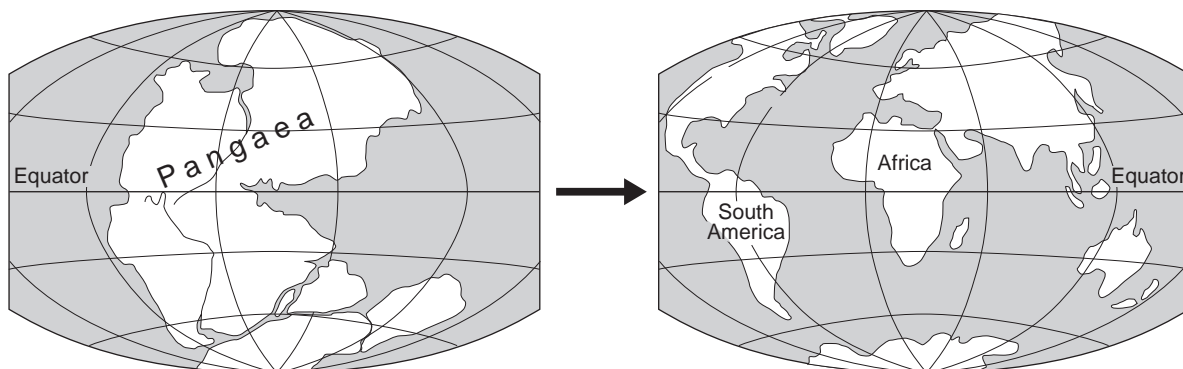

In 1912, many scientists did not accept Wegener's theory because he could not explain:

- how Pangaea had split into continents
- how the continents had moved apart.

6 (a) Wegener used evidence to support his theory.

Give **two** pieces of evidence Wegener used.

.....

.....

.....

.....

(2 marks)



6 (b) Scientists have discovered that the Earth is made up of layers.

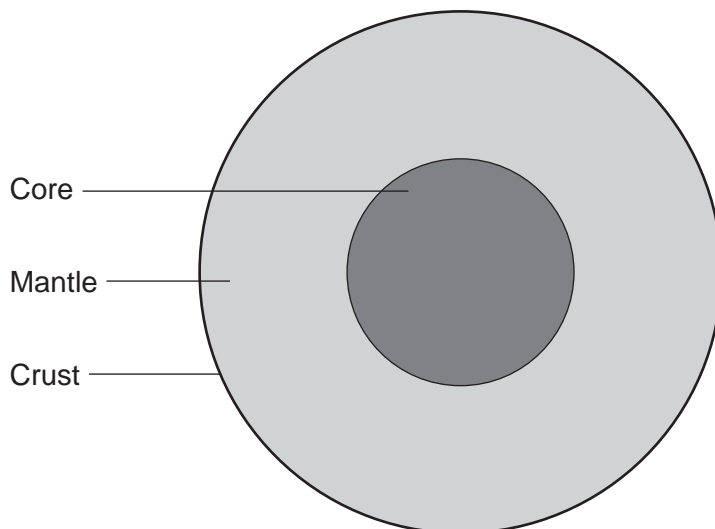

Complete the sentences by writing **one** word in each space.

Scientists now accept Wegener's theory because they know that the Earth's ..... and upper part of the mantle are cracked into tectonic plates.

The tectonic plates move at relative speeds of a few centimetres per year because of convection currents in the Earth's .....

These convection currents are driven by ..... released from natural radioactivity.

A volcanic eruption or an ..... can happen at the boundaries between tectonic plates.

(4 marks)

6

Turn over ►



7 Metals are extracted from their ores.

Many copper ores contain only 2% of copper compounds.

7 (a) Copper is now extracted from ores containing a low percentage of copper compounds.

Suggest **two** reasons why.

.....

.....

.....

.....

(2 marks)

7 (b) Chalcocite, an ore of copper, contains copper sulfide.

The flow diagram shows how copper metal is extracted from chalcocite.

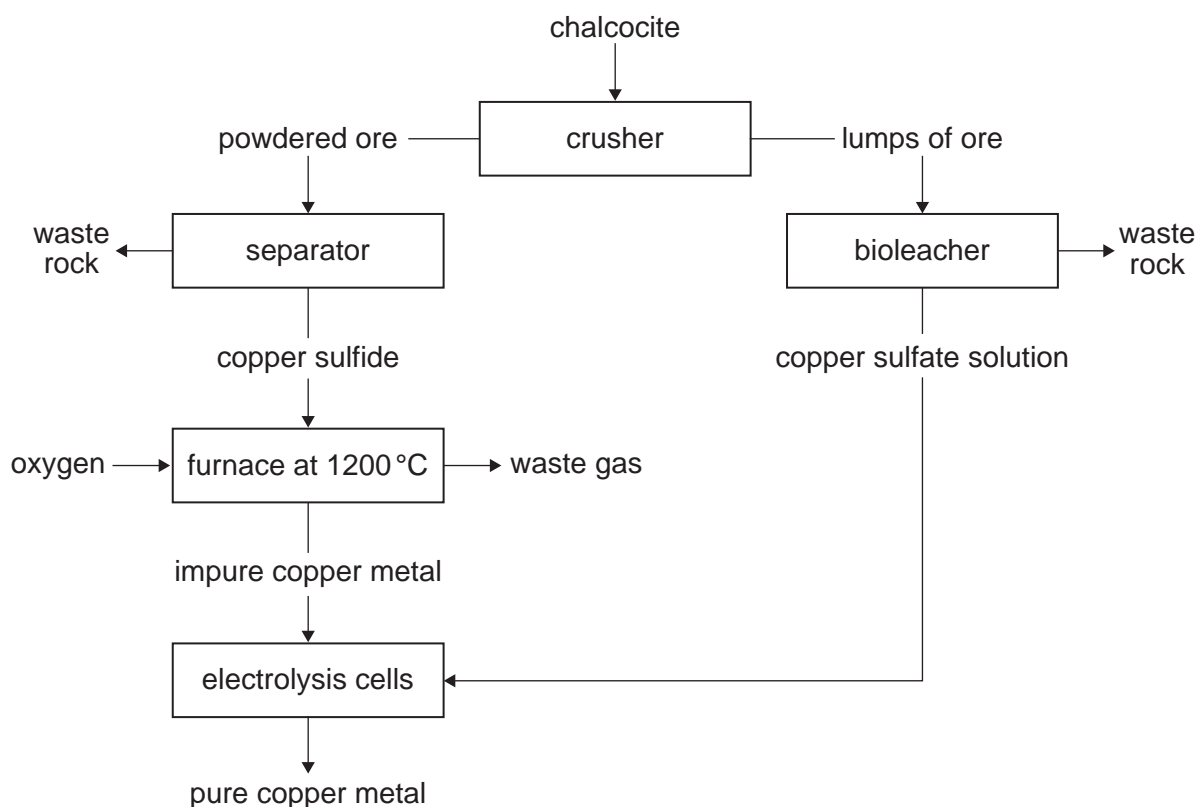



7 (b) (i) Suggest **one** reason why it is difficult to dispose of the waste rock.

.....  
.....  
(1 mark)

7 (b) (ii) The reaction in the furnace could cause environmental pollution.  
Explain how.

.....  
.....  
.....  
.....  
(2 marks)

7 (b) (iii) The extraction of pure copper is expensive.  
Give **one** reason why.

.....  
.....  
(1 mark)

7 (b) (iv) Pure copper is produced by electrolysis of copper sulfate solution.

Which electrode do the copper ions move towards?  
Give a reason for your answer.

.....  
.....  
.....  
.....  
(2 marks)

7 (b) (v) Large areas of land are contaminated with copper compounds.  
Phytomining can be used to remove these copper compounds from the land.

What is used in phytomining to remove copper compounds from the land?

.....  
.....  
(1 mark)

9

Turn over ►



**8** Crude oil is a mixture of many different chemical compounds.

**8 (a)** Fuels, such as petrol (gasoline), can be produced from crude oil.

**8 (a) (i)** Fuels react with oxygen to release energy.

Name the type of reaction that releases energy from a fuel.

.....  
(1 mark)

**8 (a) (ii)** Fuels react with oxygen to produce carbon dioxide.  
The reaction of a fuel with oxygen can produce a different oxide of carbon.

Name this different oxide of carbon and explain why it is produced.

.....  
.....  
.....  
.....  
(2 marks)

**8 (b)** Most of the compounds in crude oil are hydrocarbons.  
Hydrocarbons with the smallest molecules are very volatile.

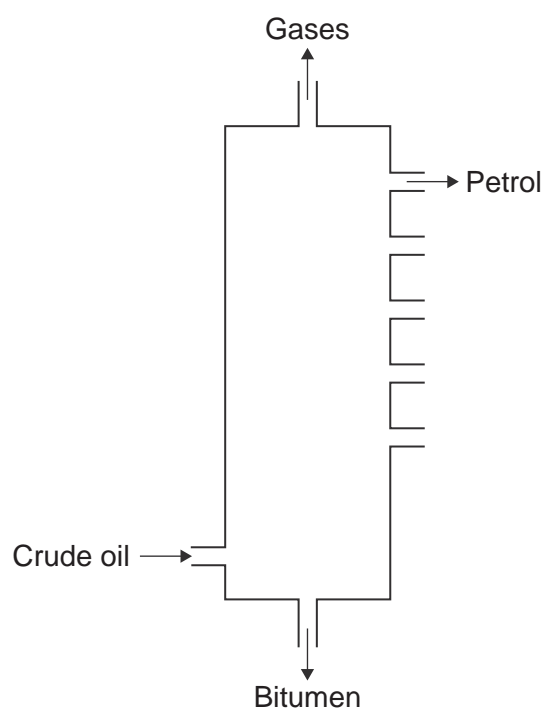



**There are no questions printed on this page**

**DO NOT WRITE ON THIS PAGE  
ANSWER IN THE SPACES PROVIDED**

ACKNOWLEDGEMENT OF COPYRIGHT-HOLDERS AND PUBLISHERS

Question 1 Photograph © Science photo library

Copyright © 2013 AQA and its licensors. All rights reserved.

