

Write your name here

Surname

Other names

Centre Number

Candidate Number

Edexcel IGCSE**Mathematics B****Paper 2**

Friday 10 June 2011 – Morning

Time: 2 hours 30 minutes

Paper Reference

4MB0/02

You must have: Ruler graduated in centimetres and millimetres, protractor, compasses, pen, HB pencil, eraser, calculator. Tracing paper may be used.

Total Marks

Instructions

- Use **black** ink or ball-point pen.
- **Fill in the boxes** at the top of this page with your name, centre number and candidate number.
- Answer **all** questions.
- Answer the questions in the spaces provided – *there may be more space than you need.*
- **Calculators may be used.**

Information

- The total mark for this paper is 100.
- The marks for **each** question are shown in brackets – *use this as a guide as to how much time to spend on each question.*

Advice

- Read each question carefully before you start to answer it.
- Check your answers if you have time at the end.
- Without sufficient working, correct answers may be awarded no marks.

Turn over ►

P38696RA

©2011 Edexcel Limited.

6/6/6/6/6



P 3 8 6 9 6 R A 0 1 2 8

edexcel 
advancing learning, changing lives

Answer ALL ELEVEN questions.

Write your answers in the spaces provided.

You must write down all stages in your working.

1 A plane flew from London to Istanbul at an average speed of 625 km/h. The flying distance was 2500 km.

(a) Calculate the time taken, in hours, for this journey. (2)

On the return journey from Istanbul to London, the time taken was 30 minutes less than the time taken from London to Istanbul. The flying distance on the return journey was also 2500 km.

(b) Calculate the average speed, in km/h, of the plane for the two journeys. Give your answer to the nearest whole number. (2)

.....

.....

.....

.....

.....

.....

.....

.....

.....

.....

.....

.....

.....

.....

.....

.....

.....

.....

.....

.....

.....

.....

.....

.....

.....

.....

.....

.....

.....

.....

.....

.....

.....

.....

(Total for Question 1 is 4 marks)



2 (a) Completely factorise $x^3 - 5x^2 + 6x$ (3)

(b) Hence, completely simplify $\frac{x^3 - 5x^2 + 6x}{2x^2 + 2x - 24}$ (3)

(Total for Question 2 is 6 marks)



P 3 8 6 9 6 R A 0 3 2 8

3

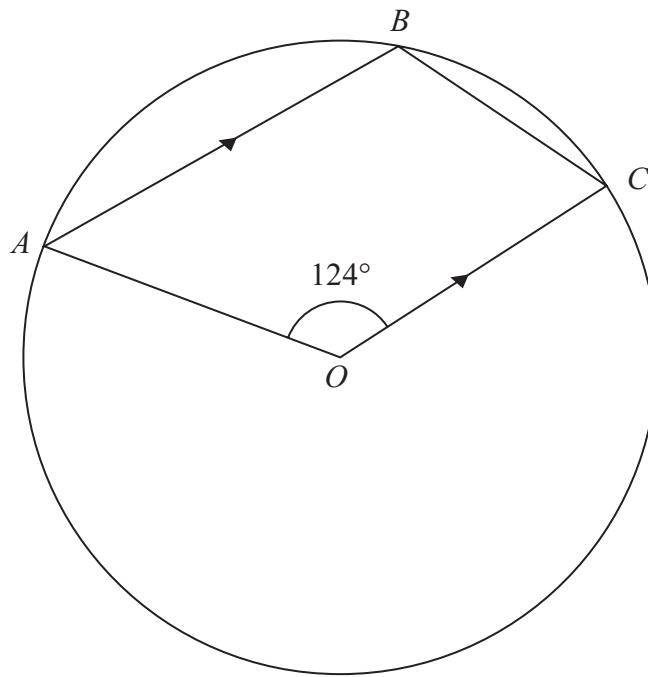

Diagram **NOT** accurately drawn

Figure 1

In Figure 1, ABC is a circle centre O . The lines AB and OC are parallel and $\angle AOC = 124^\circ$. Calculate, giving reasons, the size, in degrees, of $\angle BCO$.

.....

.....

.....

.....

.....

.....

.....

.....

.....

.....

.....

.....

.....

.....

.....

.....

.....

.....

.....

.....

.....

4



Question 3 continued

A series of horizontal dotted lines for writing, spanning the width of the page and covering most of its height.

(Total for Question 3 is 4 marks)



P 3 8 6 9 6 R A 0 5 2 8

4

Diagram NOT
accurately drawn

Figure 2

Figure 2 shows a toy made from a right circular cone and a hemisphere. The radius of the cone and the radius of the hemisphere are both 15 cm and the slant height of the cone is 39 cm.

Show that the volume of the toy is 4950π cm³.

[Volume of a right circular cone = $\frac{1}{3}\pi r^2 h$. Volume of a sphere = $\frac{4}{3}\pi r^3$]

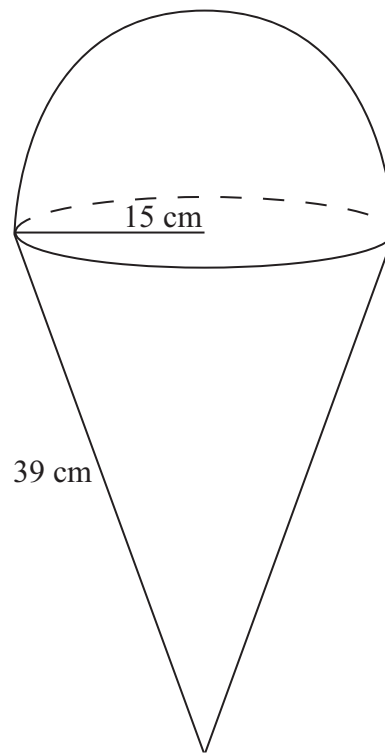
6



5

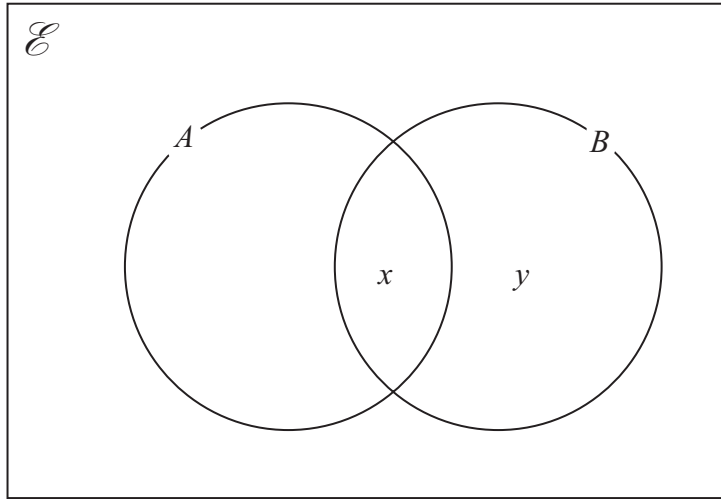

Figure 3

In Figure 3, x and y represent the number of elements in $(A \cap B)$ and $(B \cap A')$ respectively.

Given that $n(\mathcal{E}) = 35$, $n(A \cup B) = 27$ and $n(B') = 17$, find the number of elements in

(a) $(A \cup B)'$, (2)

(b) $(A \cap B)'$. (2)

Given also that $x = 2y$,

(c) calculate the value of y and the value of x . (3)

.....

.....

.....

.....

.....

.....

.....

.....

.....

.....

.....

.....

.....

.....

.....

.....



6

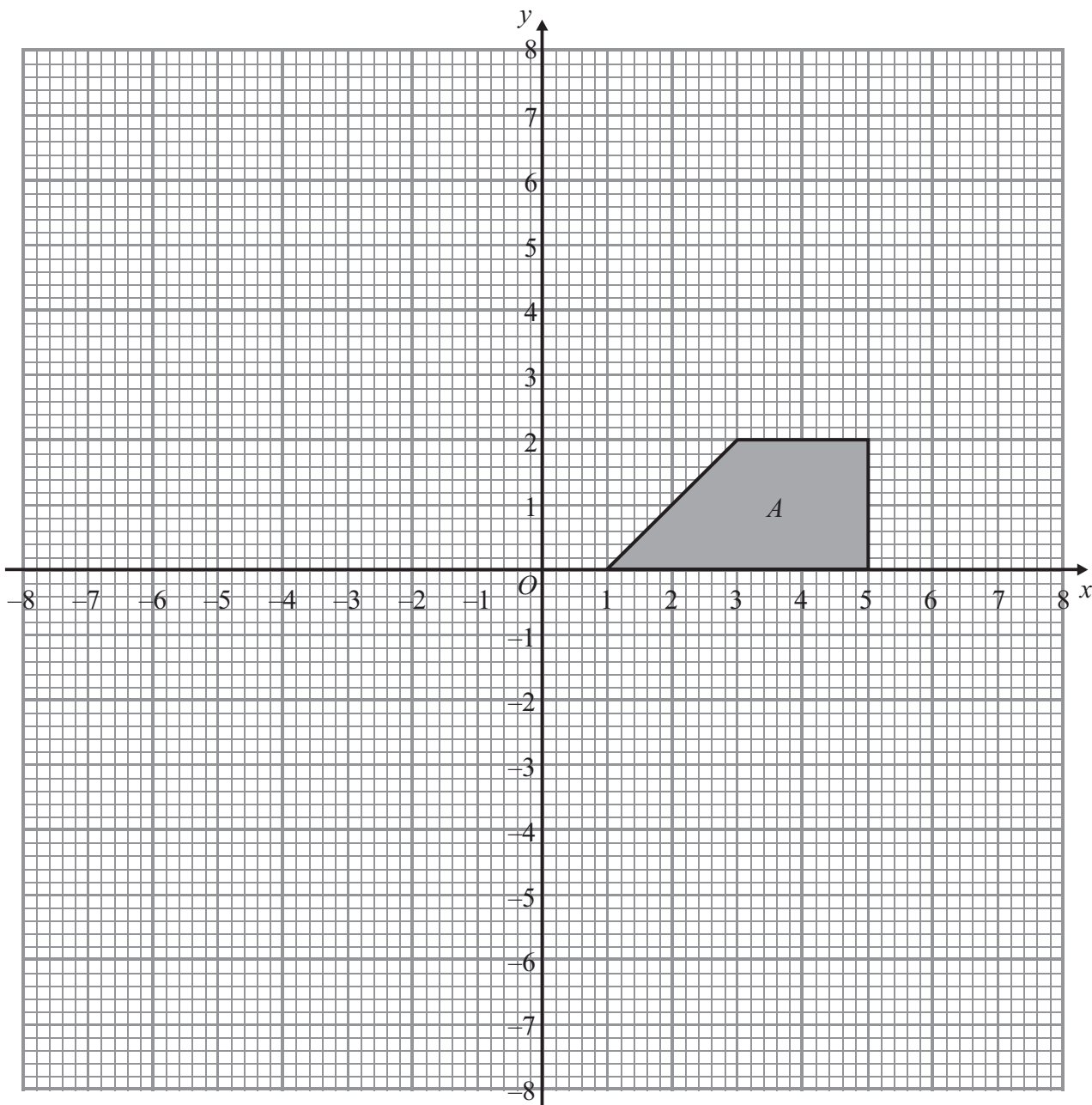

Trapezium B is the image of trapezium A following a reflection in the line $x = -1$

(a) Draw and label trapezium B .

(2)

Trapezium C is the image of trapezium B following a translation with vector $\begin{pmatrix} 0 \\ -8 \end{pmatrix}$.

(b) Draw and label trapezium C .

(2)

Trapezium D is the image of trapezium C following a rotation of 90° anticlockwise about the point $(-5, -3)$.

(c) Draw and label trapezium D .

(2)

Trapezium A is the image of trapezium D under a single transformation.

(d) Describe fully this transformation.

(2)



- 8 Left-handed and right-handed people do a test. It is found that 80% of left-handed people pass the test and 90% of right-handed people pass the test.

On the island of Sinestra, three quarters of the population are left-handed and the remainder are right-handed.

A person on Sinestra is to be chosen at random to take the test.

- (a) Write down the probability that the person chosen is right-handed. (1)

- (b) Complete the tree diagram to show all the information. (3)

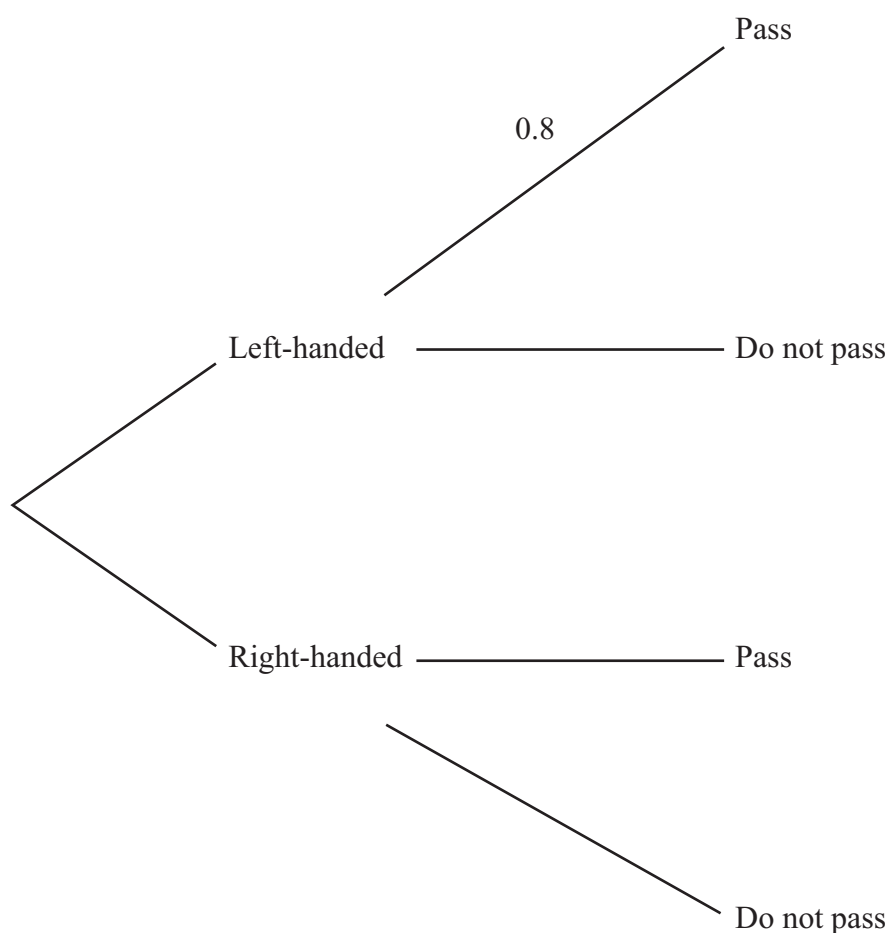

- (c) From your completed tree diagram, or otherwise, find the probability that the person chosen,
- is left-handed and will pass the test,
 - will pass the test.
- (5)

A person is selected at random from Sinestra. Given this person passed the test, use your answers to part (c) to

- (d) determine the probability that this person is left-handed. (3)



9

Diagram **NOT**
accurately drawn

Figure 4

In Figure 4, OAB is a triangle with $\vec{OA} = \mathbf{a}$ and $\vec{OB} = \mathbf{b}$.
 D is the midpoint of OA .

(a) Write down, in terms of \mathbf{a} or \mathbf{b} , or \mathbf{a} and \mathbf{b} ,

(i) \vec{OD} ,

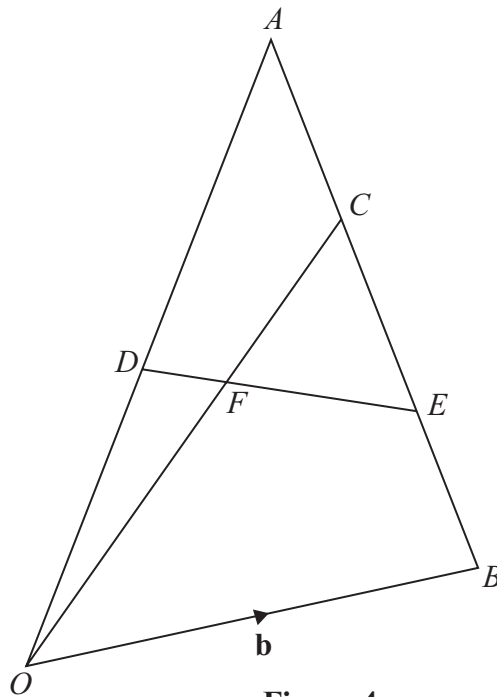
(ii) \vec{AB} .

(2)

C is the point on AB such that $AC : CB = 1 : 2$

(b) Find in terms of \mathbf{a} and \mathbf{b} , simplifying your answer, an expression for \vec{OC} .

(2)

E is the point on AB such that $AE : EB = 2 : 1$

(c) Find in terms of \mathbf{a} and \mathbf{b} , simplifying your answer, an expression for \vec{DE} .

(2)

F is the intersection of the lines OC and DE .

Given that $\vec{OF} = \lambda \vec{OC}$,

(d) express \vec{OF} in terms of λ , \mathbf{a} and \mathbf{b} .

(1)

Given that $\vec{DF} = \mu \vec{DE}$,

(e) express \vec{OF} in terms of μ , \mathbf{a} and \mathbf{b} .

(2)

(f) Find the value of μ and the value of λ .

(4)



Question 9 continued

Dotted lines for writing.



P 3 8 6 9 6 R A 0 1 7 2 8

Question 9 continued

Handwriting practice area consisting of 25 horizontal dotted lines.



Question 9 continued

A large area of the page is filled with horizontal dotted lines, providing space for writing answers.

(Total for Question 9 is 13 marks)



10

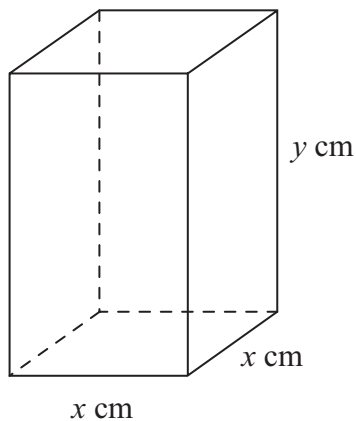

Figure 5

Figure 5 shows a solid cuboid with a square base of sides x cm and a height of y cm.

- (a) Find an expression, in terms of x and y , for the total surface area, S cm², of the cuboid. (2)

Given that the total surface area of the cuboid is 50 cm²,

- (b) find a formula for y in terms of x . (1)

The volume of the cuboid is V cm³.

- (c) Show that $V = \frac{1}{2}x(25 - x^2)$. (1)

- (d) Using calculus, calculate the value of x , to 3 significant figures, for which the volume of the cuboid is a maximum. (4)



Question 10 continued

A large area of the page is filled with horizontal dotted lines, providing space for the student's answer to Question 10.



P 3 8 6 9 6 R A 0 2 1 2 8

Question 10 continued

(e) For $V = \frac{x}{2}(25 - x^2)$, complete the table. Give your value of V to one decimal place where necessary.

x	0	1	2	2.5	3	4	5
$\frac{x}{2}$	0	0.5	1			2	2.5
$(25 - x^2)$	25	24	21			9	0
V	0	12	21			18	0

(2)

(f) On the graph paper, plot the points from your completed table and join them to form a smooth curve.

(3)

(g) By drawing a suitable straight line, estimate to one decimal place, the two values of x for which the volume of the cuboid is 20 cm^3 .

(3)

.....

.....

.....

.....

.....

.....

.....

.....

.....

.....

.....

.....

.....

.....

.....

.....

.....

.....

.....

.....

.....



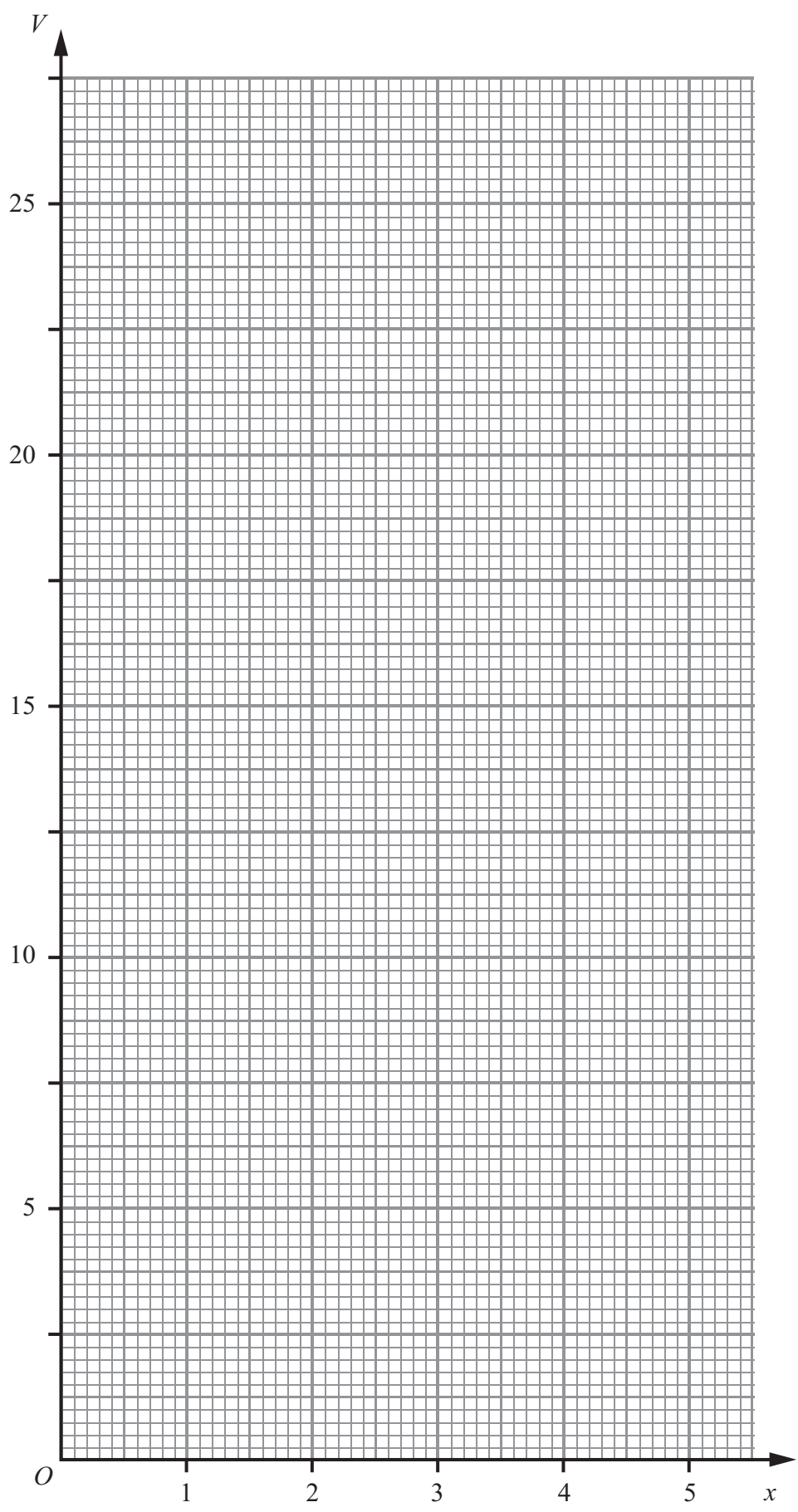

(Total for Question 10 is 16 marks)



11

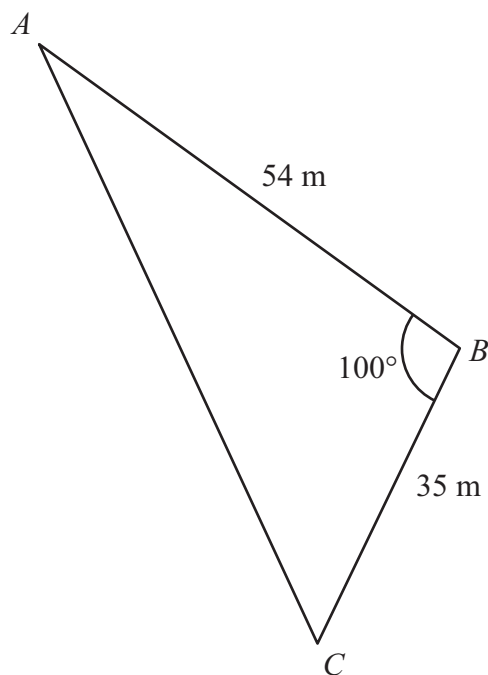

Figure 6

Figure 6 shows a triangular field on horizontal ground. $AB = 54$ m, $BC = 35$ m and $\angle ABC = 100^\circ$.

Calculate, giving your answers to 3 significant figures,

(a) the length, in m, of AC , (3)

(b) the size in degrees, of $\angle CAB$. (3)

D is the point on AC such that BD is perpendicular to AC .

(c) Calculate, giving your answer to 3 significant figures, the length, in m, of BD . (2)

A vertical mast is placed at the midpoint of BD .

(d) Calculate, giving your answer to 3 significant figures, the distance, in m, from C to the base of the mast. (6)

The angle of elevation of the top of the mast from C is 40° .

(e) Calculate, giving your answer to 3 significant figures, the height, in m, of the mast. (2)



Question 11 continued

Handwriting practice area consisting of 25 horizontal dotted lines.



Question 11 continued

.....

.....

.....

.....

.....

.....

.....

.....

.....

.....

.....

.....

.....

.....

.....

.....

.....

.....

.....

.....

.....

.....

.....

.....

.....

.....

.....

(Total for Question 11 is 16 marks)

TOTAL FOR PAPER IS 100 MARKS

END



BLANK PAGE

