

UNIVERSITY OF CAMBRIDGE INTERNATIONAL EXAMINATIONS
International General Certificate of Secondary Education

MATHEMATICS



Paper 1 (Core)

0580/01 0581/01

Candidates answer on the Question Paper.

Additional Materials: Electronic calculator

Geometrical instruments

Mathematical tables (optional)

Tracing paper (optional)

May/June 2006

1 hour

Candidate
Name

--

Centre
Number

--	--	--	--	--

Candidate
Number

--	--	--	--

READ THESE INSTRUCTIONS FIRST

Write your Centre number, candidate number and name on all the work you hand in.

Write in dark blue or black pen.

You may use a pencil for any diagrams or graphs.

Do not use staples, paper clips, highlighters, glue or correction fluid.

DO **NOT** WRITE IN THE BARCODE.

DO **NOT** WRITE IN THE GREY AREAS BETWEEN THE PAGES.

Answer **all** questions.

If working is needed for any question it must be shown below that question.

The number of marks is given in brackets [] at the end of each question or part question.

The total number of marks for this paper is 56.

Electronic calculators should be used.

If the degree of accuracy is not specified in the question, and if the answer is not exact, give the answer to three significant figures. Give answers in degrees to one decimal place.

For π , use either your calculator value or 3.142.

For Examiner's Use

--

This document consists of **8** printed pages.



- 1 The temperature at noon at an Antarctic weather centre was -15°C .
At midnight it had fallen by 12°C .
What was the temperature at midnight?

For
Examiner's
Use

Answer $^{\circ}\text{C}$ [1]

- 2 0.09 90% $\frac{9}{1000}$ 9% 0.9 $\frac{9}{100}$ 900%

Write down the three numbers from the list above which have the same value.

Answer [1]

- 3 Write down the number of square centimetres in one square metre.

Answer [1]

- 4 (a) Write down a number, other than 1, which is a **factor** of both 14 and 35.

Answer(a) [1]

- (b) Write down a number which is a **multiple** of both 14 and 35.

Answer(b) [1]

5

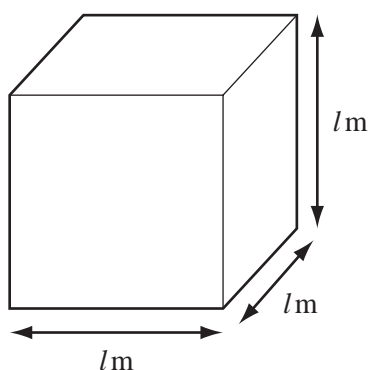

NOT TO
SCALE

A cube of side l metres has a volume of 20 cubic metres.
Calculate the value of l .

Answer $l =$ [2]

- 6 (a) Work out

$$\frac{12.48 \times 0.063}{\sqrt{8} + 7.52}$$

For
Examiner's
Use

Write down all the figures on your calculator display.

Answer(a) [1]

- (b) Write your answer to
- part (a)**
- correct to 2 significant figures.

Answer(b) [1]

- 7 The population of a city is 350 000 correct to the nearest ten thousand.
-
- Complete the statement about the limits of the population.

Answer \leq population < [2]

- 8 Factorise completely
- $2x^2 - 6xy$
- .

Answer [2]

- 9 (a) A bowl of fruit contains 3 apples, 4 bananas, 2 pears and 1 orange.
-
- Aminata chooses one piece of fruit at random.
-
- What is the probability that she chooses

- (i) a banana,

Answer(a)(i) [1]

- (ii) a mango?

Answer(a)(ii) [1]

- (b) The probability that it will rain in Switzerland on 1
- st
- September is
- $\frac{5}{12}$
- .

State the probability that it will **not** rain in Switzerland on 1st September.

Answer(b) [1]

- 10 Simplify

(a) $p^2 \times p^3$,

Answer(a) [1]

(b) $q^3 \div q^{-4}$,

Answer(b) [1]

(c) $(r^2)^3$.

Answer(c) [1]

11 Rodriguez puts \$500 into a bank account. The bank pays 5% compound interest per year.

(a) How much is the interest after one year?

Answer(a) \$ [1]

(b) Work out the **total amount** he has in his bank account after two years.

Answer(b) \$ [2]

12 (a) Draw all the lines of symmetry on the following shapes. (Shape B is a regular polygon.)

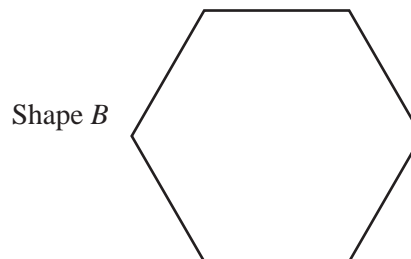
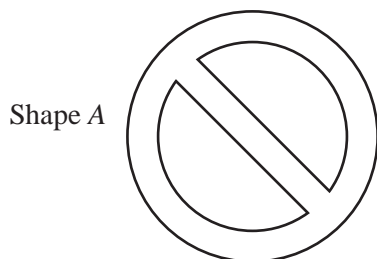

[2]

(b) Write down the order of rotational symmetry of shape A.

Answer(b) [1]

13 Solve the simultaneous equations

$$\begin{aligned} 3x - y &= 18, \\ 2x + y &= 7. \end{aligned}$$

Answer x =

y = [3]

14 (a) Pierre arrives at school at 08 40 and leaves at 15 30.
How long, in hours and minutes, is he in school?

Answer(a) h min [1]

(b) Each day, Pierre gets up at 07 00 and goes to bed at 22 00.
What percentage of each day is he in bed?

Answer(b) % [2]

15 $\vec{AB} = \begin{pmatrix} -1 \\ 4 \end{pmatrix}$ and $\vec{CD} = 3\vec{AB}$.

(a) Write \vec{CD} as a column vector.

Answer(a) $\vec{CD} = \begin{pmatrix} \\ \end{pmatrix}$ [1]

(b) Make two statements about the relationship between the lines AB and CD .

Statement 1

Statement 2 [2]

16 Yousef asked 24 students to choose their favourite sport. He recorded the information in the table below so that he could draw a pie chart.

(a) Complete the table.

Sport	Volleyball	Football	Hockey	Cricket
Number of students	6	9	7	2
Angle on pie chart	90°	135°		

[2]

(b) Complete the pie chart accurately to show this data.

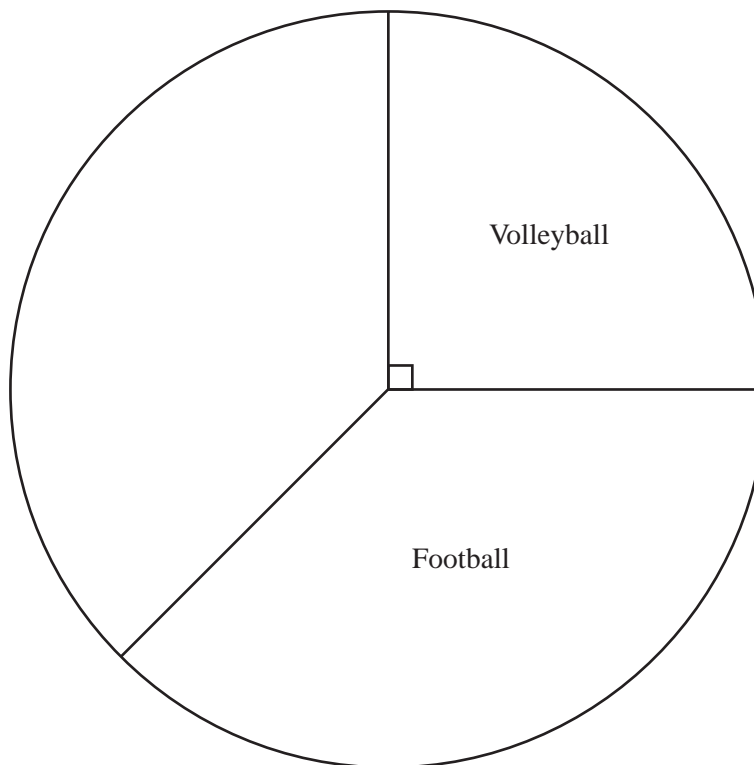

[1]

(c) Which is the modal sport?

Answer(c) [1]

17

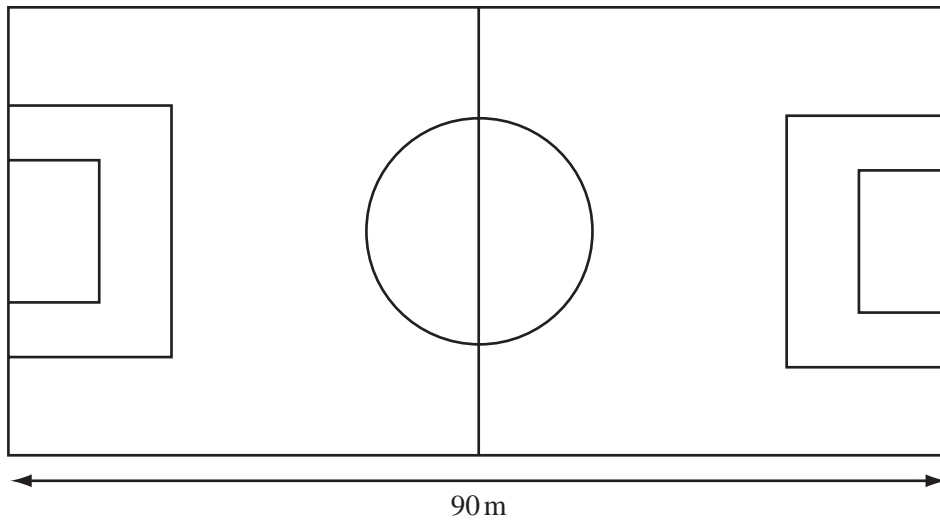

NOT TO SCALE

For
Examiner's
Use

- (a) The diagram shows the plan for a new soccer field.
 The length of the pitch is 90 metres.
 The ratio length : width is 5 : 3.
 Calculate the width of the pitch.

Answer(a) m [2]

- (b) The centre circle has a circumference of 57.5 metres.
 Calculate the radius.

Answer(b) m [2]

18

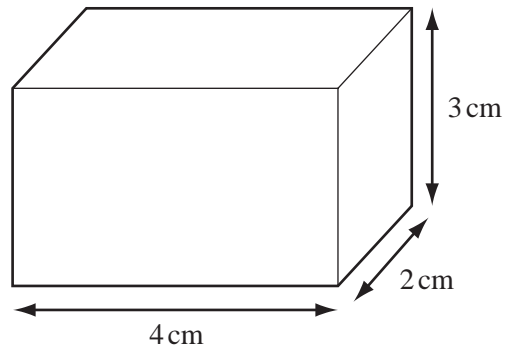

NOT TO SCALE

For Examiner's Use

The solid shown is a cuboid with length 4 cm, width 2 cm and height 3 cm.

(a) Draw an accurate net of the cuboid on the grid below.

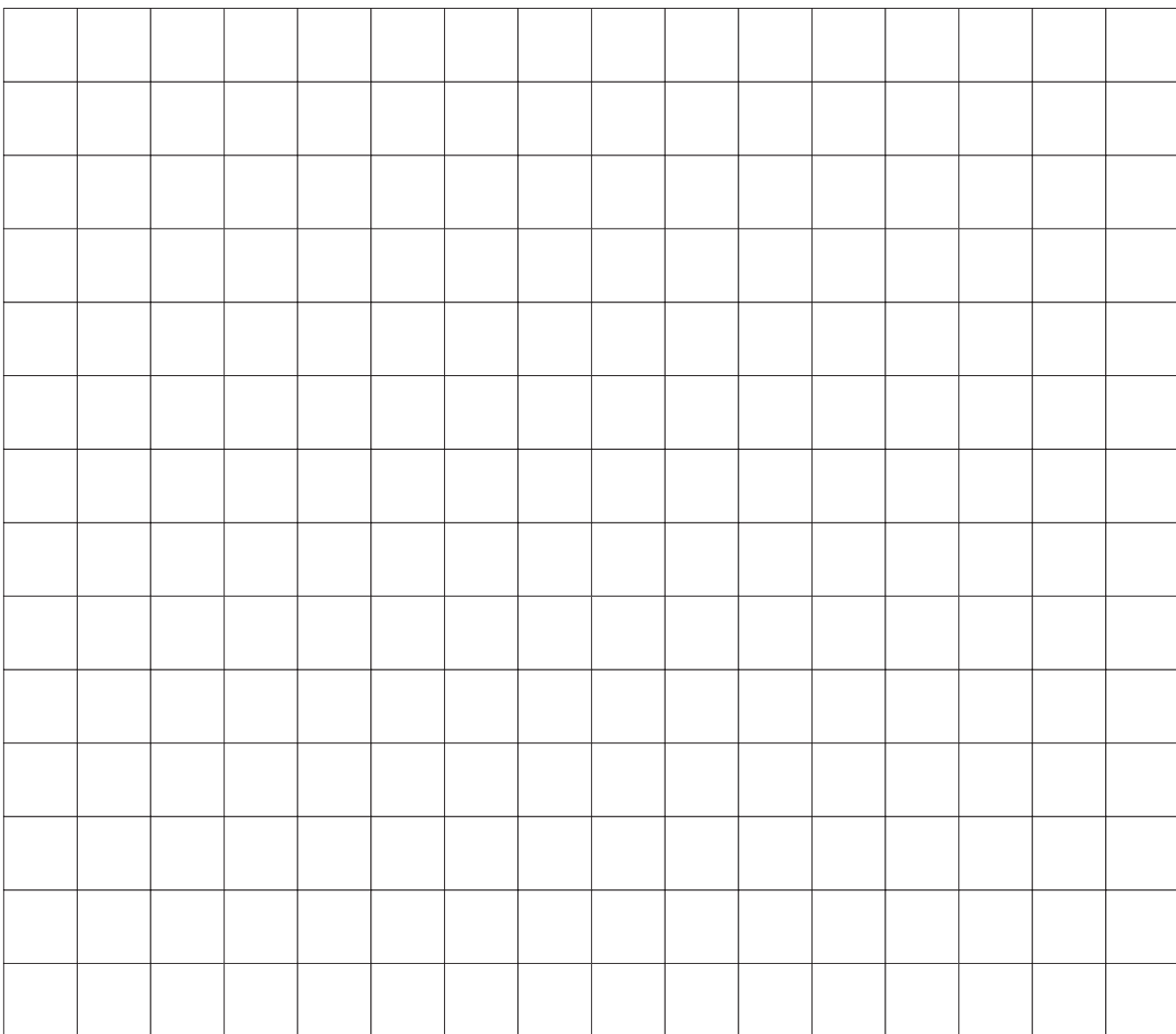

[2]

(b) Using your net, calculate the total surface area of the cuboid.

Answer(b) cm² [2]

- 19 Joseph, Maria and Rebecca each win a prize.
Their total prize money is \$30.

Joseph wins $\frac{7}{12}$ of the \$30.

Maria wins 30% of the \$30.

Rebecca wins the rest of the \$30.

Calculate the amount each receives.

For
Examiner's
Use

Answer Joseph \$..... [2]

Maria \$..... [2]

Rebecca \$..... [1]

- 20 There are 565 sheets of paper in a book.

- (a) How many sheets of paper are there in 2000 of these books?
Give your answer in standard form.

Answer(a) [2]

- (b) A pile of 565 sheets of paper is 25 millimetres high.
Calculate the thickness of 1 sheet of paper.
Give your answer in standard form.

Answer(b) mm [3]

Permission to reproduce items where third-party owned material protected by copyright is included has been sought and cleared where possible. Every reasonable effort has been made by the publisher (UCLES) to trace copyright holders, but if any items requiring clearance have unwittingly been included, the publisher will be pleased to make amends at the earliest possible opportunity.

University of Cambridge International Examinations is part of the University of Cambridge Local Examinations Syndicate (UCLES), which is itself a department of the University of Cambridge.