



Cambridge IGCSE™

CANDIDATE
NAME

CENTRE
NUMBER

--	--	--	--	--

CANDIDATE
NUMBER

--	--	--	--



PHYSICS

0625/53

Paper 5 Practical Test

October/November 2021

1 hour 15 minutes

You must answer on the question paper.

You will need: The materials and apparatus listed in the confidential instructions

INSTRUCTIONS

- Answer **all** questions.
- Use a black or dark blue pen. You may use an HB pencil for any diagrams or graphs.
- Write your name, centre number and candidate number in the boxes at the top of the page.
- Write your answer to each question in the space provided.
- Do **not** use an erasable pen or correction fluid.
- Do **not** write on any bar codes.
- You may use a calculator.
- You should show all your working and use appropriate units.

INFORMATION

- The total mark for this paper is 40.
- The number of marks for each question or part question is shown in brackets [].

For Examiner's Use	
1	
2	
3	
4	
Total	

This document has **12** pages. Any blank pages are indicated.

1 In this experiment, you will investigate the effect of insulation on the cooling of water.

Carry out the following instructions, referring to Fig. 1.1.

Beaker A is covered with material that is a thermal insulator.

Beaker B is identical to beaker A but has no insulation.

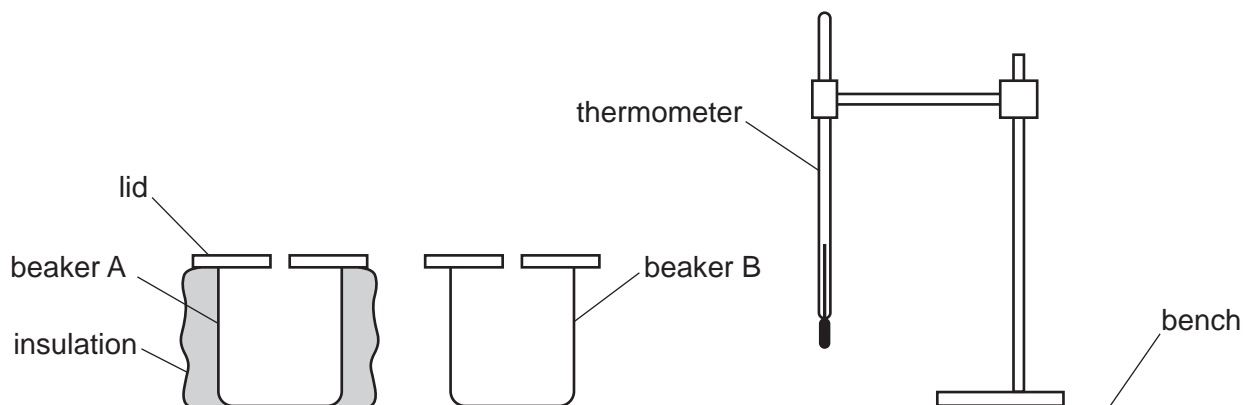

Fig. 1.1

- (a)
- Remove the lid from beaker A.
 - Pour 150 cm^3 of hot water into beaker A and replace the lid.
 - Place the thermometer in the water in beaker A.

In the first row of Table 1.1, record the temperature θ of the water at $t = 0$ and immediately start the stop-clock.

Record, in Table 1.1, the temperature θ of the water at times $t = 30\text{ s}$, $t = 60\text{ s}$, $t = 90\text{ s}$, $t = 120\text{ s}$, $t = 150\text{ s}$ and $t = 180\text{ s}$.

[1]

- Remove the thermometer from the beaker.

(b) (i) Repeat (a) for beaker B. [2]

(ii) Add units to the column headings in Table 1.1. [1]

Table 1.1

	beaker A with insulation	beaker B without insulation
$t/$	$\theta/$	$\theta/$
0		
30		
60		
90		
120		
150		
180		

- (c) Write a conclusion stating whether the insulation affects the rate of cooling of the water. Justify your answer by reference to values from your results.

.....

 [2]

- (d) (i) Calculate the average cooling rate x_1 during the first half of the experiment for the water in beaker B. Use your readings for beaker B from Table 1.1 and the equation

$$x_1 = \frac{\theta_0 - \theta_{90}}{T},$$

where $T = 90\text{ s}$ and θ_0 and θ_{90} are the temperatures of the water in beaker B at $t = 0$ and $t = 90\text{ s}$.

Include the unit.

$$x_1 = \dots\dots\dots [1]$$

4

- (ii) Calculate the average cooling rate x_2 during the second half of the experiment for the water in beaker B. Use your readings for beaker B from Table 1.1 and the equation

$$x_2 = \frac{\theta_{90} - \theta_{180}}{T},$$

where $T = 90\text{s}$ and θ_{90} and θ_{180} are the temperatures of the water in beaker B at $t = 90\text{s}$ and $t = 180\text{s}$.

Include the unit.

$$x_2 = \dots\dots\dots [1]$$

- (e) (i) Suggest an additional experiment to test whether the lid affects the cooling rate of the water in beaker B. State how the readings are used to show the effect.

You are **not** required to carry out this additional experiment.

.....

 [1]

- (ii) A student suggests that the temperature of the water in beaker B at $t = 0$ for this additional experiment must be the same as in **(b)(i)** for the comparison to be fair.

State whether your results support this suggestion.

Use your results from **(d)** to explain whether this precaution is necessary.

statement

explanation

.....
 [2]

[Total: 11]

- 2 In this experiment, you will compare the resistances of two wires. The circuit has been set up for you.

Carry out the following instructions, referring to Fig. 2.1.

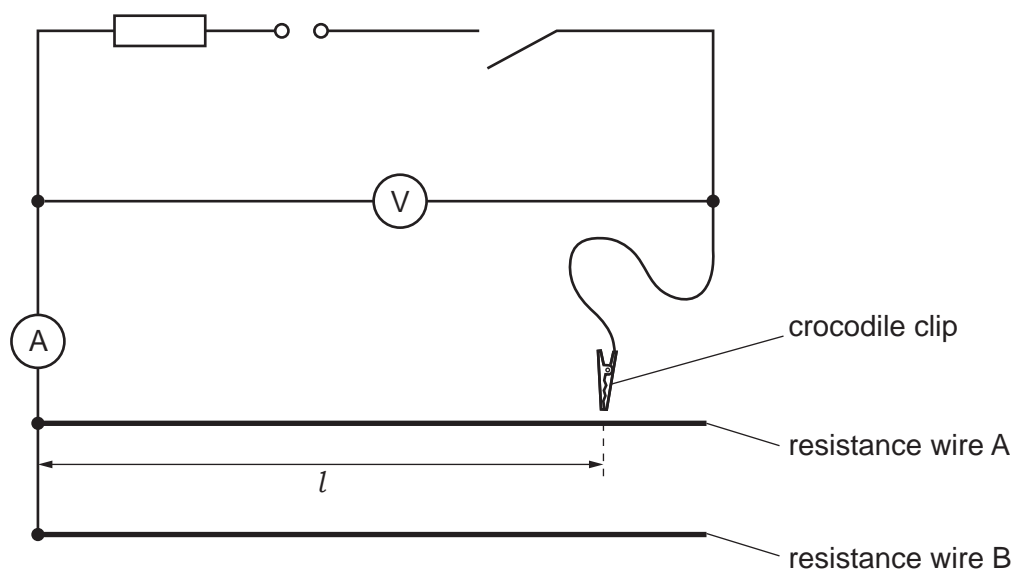

Fig. 2.1

- (a) Connect the crocodile clip to a length $l = 90.0$ cm of resistance wire A.

Close the switch.

Measure, and record in Table 2.1, the value of potential difference (p.d.) V and current I for the wire.

Open the switch.

Calculate, and record in Table 2.1, the resistance R of 90.0 cm of wire A.

Use your values of V and I and the equation

$$R = \frac{V}{I}.$$

[3]

Table 2.1

wire	l/cm	$V/$	$I/$	$R/$
A	90.0			
B	90.0			
A	50.0			
B	50.0			

(b) (i) Repeat step (a) for $l = 90.0\text{ cm}$ of wire B, $l = 50.0\text{ cm}$ of wire A and $l = 50.0\text{ cm}$ of wire B. [2]

(ii) Complete the headings in Table 2.1. [1]

(c) (i) Calculate a value P using your results from Table 2.1 and the equation

$$P = \frac{R \text{ for } 90.0\text{ cm of wire A}}{R \text{ for } 90.0\text{ cm of wire B}}$$

$$P = \dots\dots\dots [1]$$

(ii) Calculate a value Q using your results from Table 2.1 and the equation

$$Q = \frac{R \text{ for } 50.0\text{ cm of wire A}}{R \text{ for } 50.0\text{ cm of wire B}}$$

$$Q = \dots\dots\dots [1]$$

(iii) A student suggests that the values of P and Q should be equal.

State whether your results support this suggestion. Justify your answer by reference to values from your results.

statement

justification

.....

.....

[2]

(d) Suggest **one** reason why students all doing this experiment carefully with the same apparatus may not obtain the same results.

.....

..... [1]

[Total: 11]

3 In this experiment, you will investigate the image produced by a converging lens.

Carry out the following instructions, referring to Fig. 3.1.

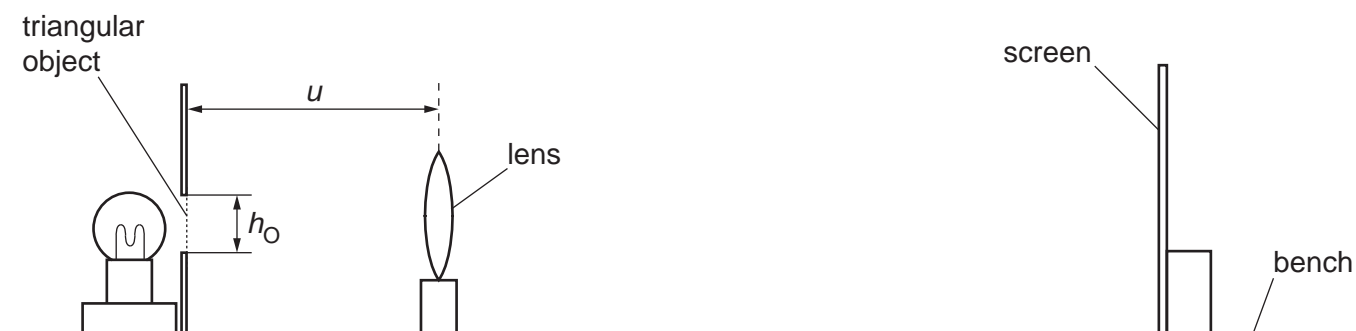

Fig. 3.1

(a) Measure and record the height h_o of the triangular object.

$h_o = \dots\dots\dots$ cm

- Place the lens a distance $u = 20.0$ cm from the triangular object.
- Place the screen close to the lens.
- Switch on the lamp.
- Move the screen away from the lens until a clear, focused image of the triangular object is seen on the screen.
- Measure, and record in Table 3.1, the height h_i of the image.

Repeat the procedure for $u = 25.0$ cm, $u = 30.0$ cm, $u = 35.0$ cm and $u = 40.0$ cm.

Switch off the lamp.

Table 3.1

u/cm	h_i/cm	$\frac{1}{h_i} / \frac{1}{\text{cm}}$
20.0		
25.0		
30.0		
35.0		
40.0		

[1]

(b) For each distance u , calculate, and record in Table 3.1, the value of $\frac{1}{h_i}$.

[1]

8

- (c) Plot a graph of u/cm (y -axis) against $\frac{1}{h_1} / \frac{1}{\text{cm}}$ (x -axis). Start the axes at the origin (0,0).

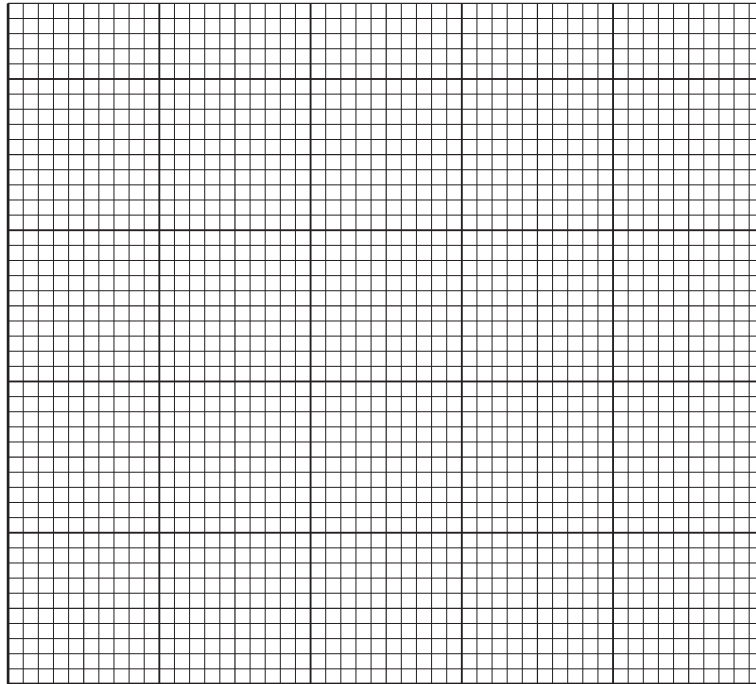

[4]

- (d) (i) From your graph, determine u_0 , the value of u when $\frac{1}{h_1} = 0.0$.

$u_0 = \dots\dots\dots$ [1]

- (ii) Determine the gradient of the graph.

Show clearly on the graph how you obtained the necessary information.

gradient = $\dots\dots\dots$ [1]

- (iii) Calculate the focal length f of the lens. Use your value of h_0 from (a) and the equation

$$f = \frac{G}{h_0},$$

where G is numerically equal to the gradient from (d)(ii).

$f = \dots\dots\dots$ [1]

(e) Describe **one** difficulty that can be experienced when measuring the height of the image.

Suggest an improvement to overcome this difficulty.

difficulty

.....

improvement

.....

[2]

[Total: 11]

4 A student investigates the strength of an electromagnet.

The electromagnet is made from a coil of insulated wire wrapped around an iron rod. When there is an electric current in the coil, the iron rod becomes magnetised. The electromagnet can then attract magnetic materials (e.g. iron and steel).

Plan an experiment to investigate how **one** factor affects the number of steel paper clips the electromagnet can support.

You are **not** required to carry out the experiment.

The apparatus available includes:

- an electromagnet, shown in Fig. 4.1
- a power supply
- a selection of steel paper clips.

In your plan, you should:

- state a factor which can be measured and list any additional apparatus needed
- state the key variables to be kept constant
- explain briefly how to do the experiment, including any precautions to ensure reliable results (you may draw a diagram or add to Fig. 4.1 to help your explanation)
- draw a table, or tables, with column headings, to show how to display the readings (you are **not** required to enter any readings in the table)
- explain how to use the readings to reach a conclusion.

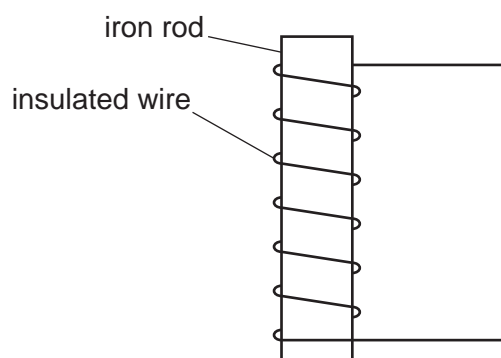

Fig. 4.1

BLANK PAGE

Permission to reproduce items where third-party owned material protected by copyright is included has been sought and cleared where possible. Every reasonable effort has been made by the publisher (UCLES) to trace copyright holders, but if any items requiring clearance have unwittingly been included, the publisher will be pleased to make amends at the earliest possible opportunity.

To avoid the issue of disclosure of answer-related information to candidates, all copyright acknowledgements are reproduced online in the Cambridge Assessment International Education Copyright Acknowledgements Booklet. This is produced for each series of examinations and is freely available to download at www.cambridgeinternational.org after the live examination series.

Cambridge Assessment International Education is part of the Cambridge Assessment Group. Cambridge Assessment is the brand name of the University of Cambridge Local Examinations Syndicate (UCLES), which itself is a department of the University of Cambridge.