



Cambridge International Examinations
Cambridge International General Certificate of Secondary Education

CANDIDATE
NAME

CENTRE
NUMBER

--	--	--	--	--

CANDIDATE
NUMBER

--	--	--	--

* 0 8 0 0 4 5 9 5 9 0 *



CHEMISTRY

0620/62

Paper 6 Alternative to Practical

October/November 2016

1 hour

Candidates answer on the Question Paper.

No Additional Materials are required.

READ THESE INSTRUCTIONS FIRST

Write your Centre number, candidate number and name on all the work you hand in.

Write in dark blue or black pen.

You may use an HB pencil for any diagrams or graphs.

Do not use staples, paper clips, glue or correction fluid.

DO NOT WRITE IN ANY BARCODES.

Answer **all** questions.

Electronic calculators may be used.

You may lose marks if you do not show your working or if you do not use appropriate units.

At the end of the examination, fasten all your work securely together.

The number of marks is given in brackets [] at the end of each question or part question.

The syllabus is approved for use in England, Wales and Northern Ireland as a Cambridge International Level 1/Level 2 Certificate.

This document consists of **9** printed pages and **3** blank pages.

- 1 This question is about the separation of mixtures.
The diagram shows four sets of apparatus that can be used to separate mixtures.

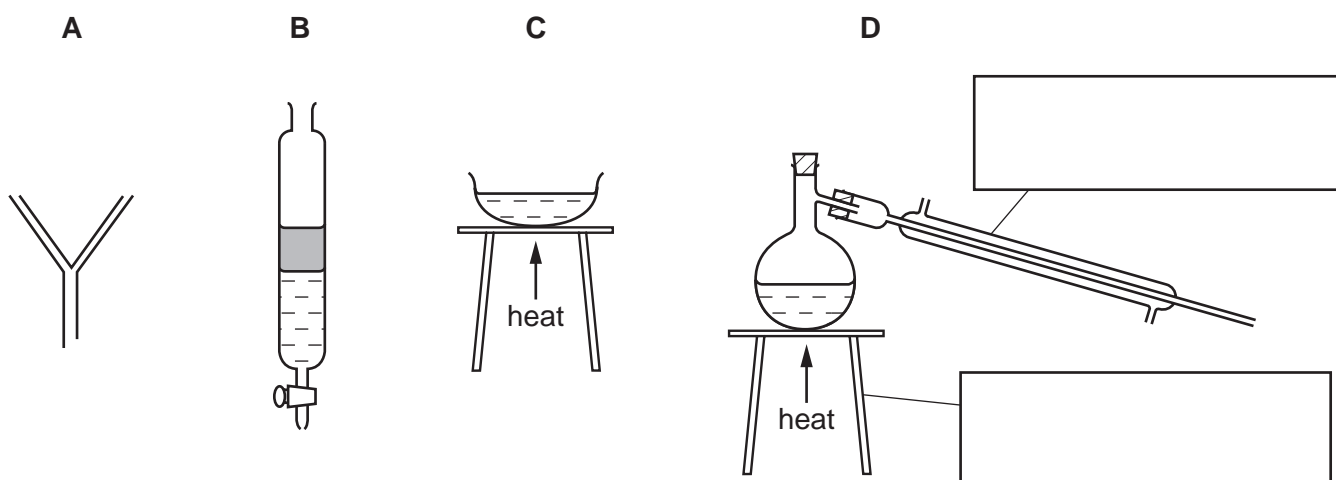

- (a) Complete the boxes to name the apparatus. [2]

- (b) The table shows four different mixtures.

Complete the table to show which set of apparatus should be used to obtain the substance listed. The first one has been completed for you. Each set of apparatus can be used once, more than once or not at all.

mixture	to obtain	use apparatus
petroleum and water	petroleum	B
sodium chloride dissolved in water	sodium chloride crystals
sodium chloride dissolved in water	water
insoluble silver chloride and water	silver chloride

[3]

- (c) Put a ring around the separation method that should be used to separate a mixture of coloured dyes.

centrifugation chromatography condensation evaporation

[1]

[Total: 6]

3

- 2 A student investigated the rate of reaction between dilute hydrochloric acid and excess magnesium at room temperature. The apparatus was set up as shown in the diagram.

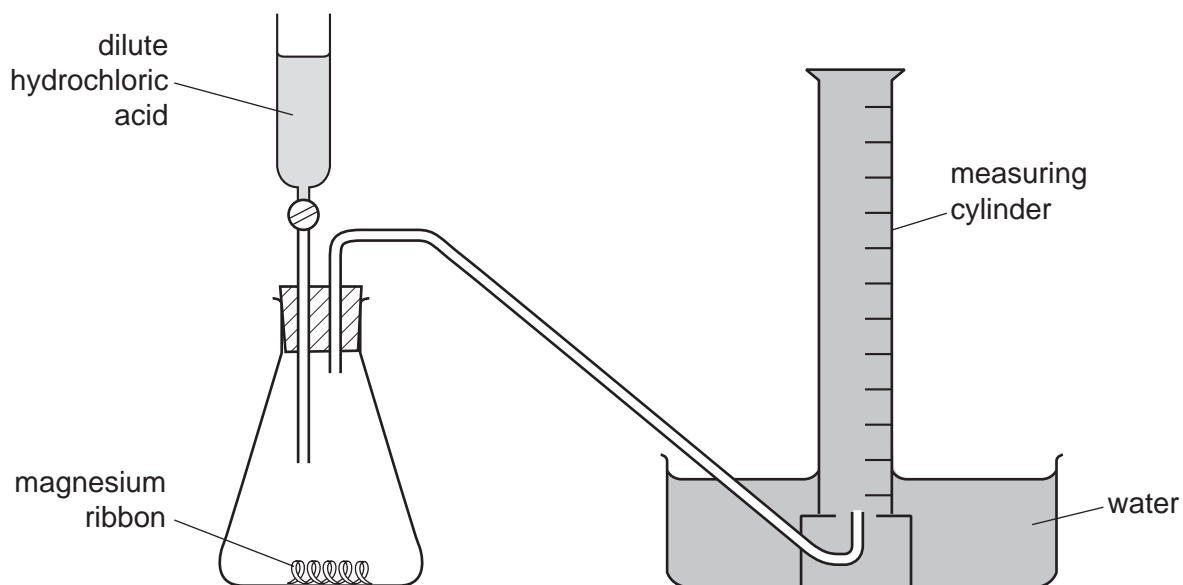

30 cm³ of dilute hydrochloric acid were added to the conical flask containing magnesium ribbon. The timer was then started and the volume of gas collected in the measuring cylinder was measured every 20 seconds for 180 seconds (3 minutes).

(a) Use the measuring cylinder diagrams to record the total volume of gas collected in the table.

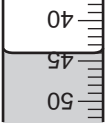
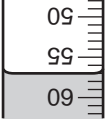
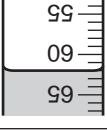
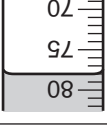
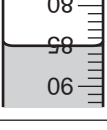
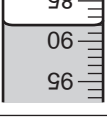
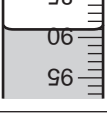
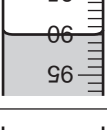
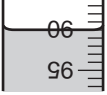
time/s	measuring cylinder diagram	total volume of gas collected/cm ³
0		30
20		
40		
60		
80		
100		
120		
140		
160		
180		

[2]

5

(b) Plot the results on the grid and draw a smooth line graph.

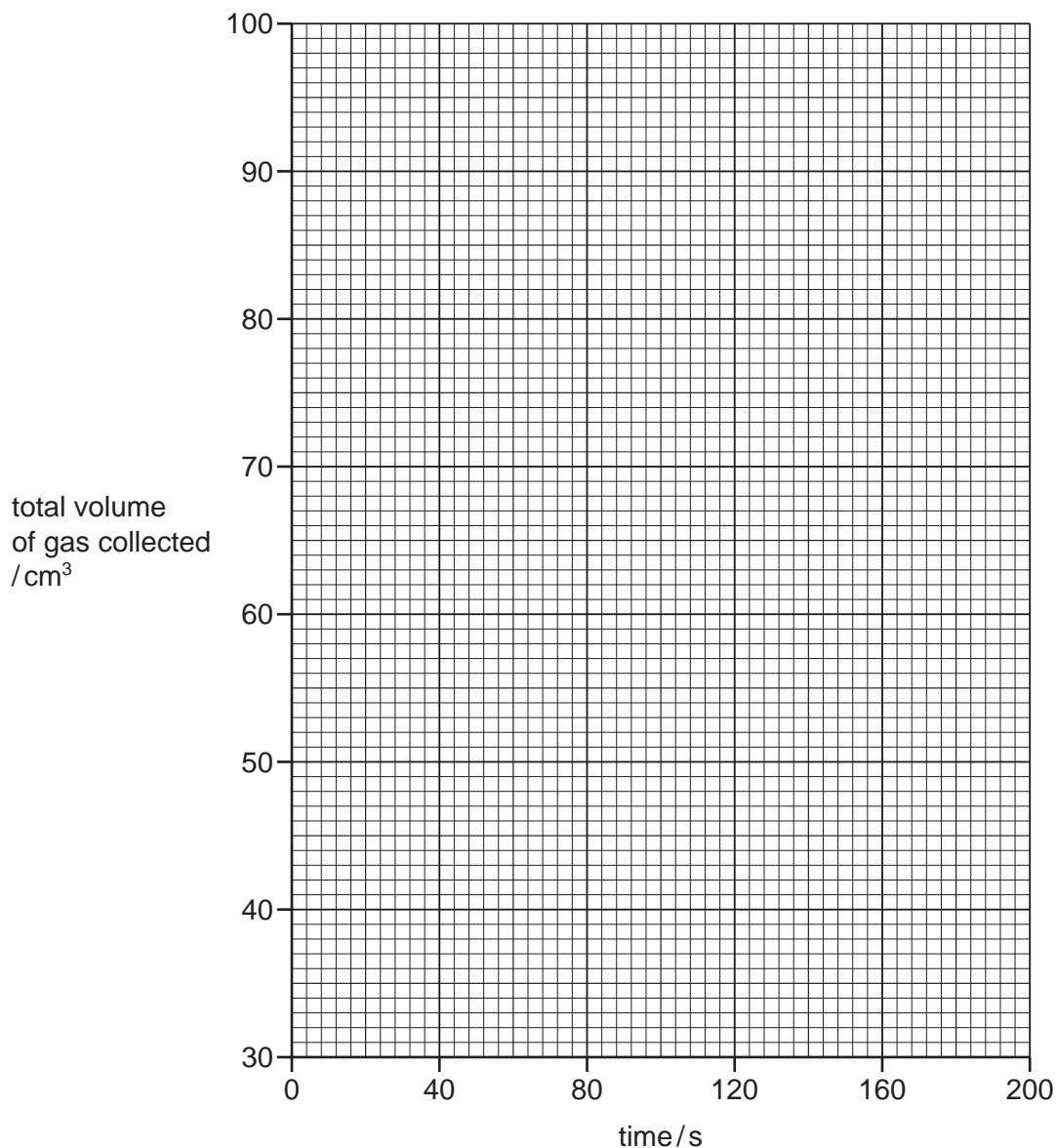

[3]

(c) (i) Which result is anomalous?

..... [1]

(ii) Suggest a possible reason for this anomalous result.

..... [1]

(iii) **Use your graph** to deduce the total volume of gas that you would have expected to collect instead of this anomalous volume.
Show clearly **on the grid** how you worked out your answer.

..... cm³ [2]

6

- (d) Explain why the total volume of gas collected does **not** increase after 160 seconds.

.....
 [2]

- (e) The average rate of the reaction can be calculated using the equation shown.

$$\text{average rate of reaction} = \frac{\text{volume of gas collected/cm}^3}{\text{time/s}}$$

- (i) Calculate the volume of gas collected between 20 seconds and 40 seconds.

..... [1]

- (ii) Calculate the average rate of reaction between 20 seconds and 40 seconds.
 Include the unit.

average rate of reaction = [2]

- (f) Room temperature was 20 °C.

Sketch **on the grid** the graph you would expect if the experiment were repeated at 30 °C. [2]

- (g) Suggest why the reading on the measuring cylinder was 30 cm³ after the acid had been added and before the timer had been started.

.....
 [1]

- (h) Suggest and explain **one** improvement to this experiment.

.....

 [2]

[Total: 19]

- 3 Two solutions, solution **S** and solution **T**, were analysed. Solution **S** was dilute hydrochloric acid. The tests on solution **S** and solution **T**, and some of the observations, are shown.

tests on solution S

- (a) Solution **S** was divided into four equal portions in four test-tubes. The following tests were carried out.

Complete the observations for **tests 1–4**.

(i) **test 1**

The pH of the first portion of solution **S** was tested.

pH [1]

(ii) **test 2**

Copper(II) oxide was added to the second portion of the solution. The mixture was heated.

observations

.....

..... [2]

(iii) **test 3**

Solid sodium carbonate was added to the third portion of the solution. The gas given off was tested.

observations

..... [3]

(iv) **test 4**

Dilute nitric acid and aqueous silver nitrate were added to the fourth portion of the solution.

observations [1]

tests on solution T

(b) Tests were carried out on solution **T** and the following observations made.

tests	observations
<p>Solution T was divided into three equal portions in three test-tubes.</p> <p>Appearance of the solution.</p>	<p>yellow solution</p>
<p>Drops of aqueous sodium hydroxide were added to the second portion of the solution and the test-tube shaken.</p> <p>Excess aqueous sodium hydroxide was then added to the test-tube.</p>	<p>red-brown precipitate</p> <p>no visible change</p>
<p>Aqueous sodium hydroxide and aluminium foil were added to the third portion of the solution and the mixture heated.</p> <p>The gas given off was tested with pH indicator paper.</p>	<p>pungent gas formed, pH 10</p>

Identify solution **T**.

.....
 [2]

[Total: 9]

BLANK PAGE

Permission to reproduce items where third-party owned material protected by copyright is included has been sought and cleared where possible. Every reasonable effort has been made by the publisher (UCLES) to trace copyright holders, but if any items requiring clearance have unwittingly been included, the publisher will be pleased to make amends at the earliest possible opportunity.

To avoid the issue of disclosure of answer-related information to candidates, all copyright acknowledgements are reproduced online in the Cambridge International Examinations Copyright Acknowledgements Booklet. This is produced for each series of examinations and is freely available to download at www.cie.org.uk after the live examination series.

Cambridge International Examinations is part of the Cambridge Assessment Group. Cambridge Assessment is the brand name of University of Cambridge Local Examinations Syndicate (UCLES), which is itself a department of the University of Cambridge.