



UNIVERSITY OF CAMBRIDGE INTERNATIONAL EXAMINATIONS  
International General Certificate of Secondary Education

**PHYSICS**

**0625/11**

Paper 1 Multiple Choice

**October/November 2009**

**45 minutes**

Additional Materials:      Multiple Choice Answer Sheet  
   Soft clean eraser  
   Soft pencil (type B or HB recommended)



**READ THESE INSTRUCTIONS FIRST**

Write in soft pencil.

Do not use staples, paper clips, highlighters, glue or correction fluid.

Write your name, Centre number and candidate number on the Answer Sheet in the spaces provided unless this has been done for you.

There are **forty** questions on this paper. Answer **all** questions. For each question there are four possible answers **A, B, C** and **D**.

Choose the **one** you consider correct and record your choice in **soft pencil** on the separate Answer Sheet.

**Read the instructions on the Answer Sheet very carefully.**

Each correct answer will score one mark. A mark will not be deducted for a wrong answer.

Any rough working should be done in this booklet.

This document consists of **16** printed pages.



## 2

- 1 A stopwatch is used to time an athlete running 100 m. The timekeeper forgets to reset the watch to zero before using it to time another athlete running 100 m.

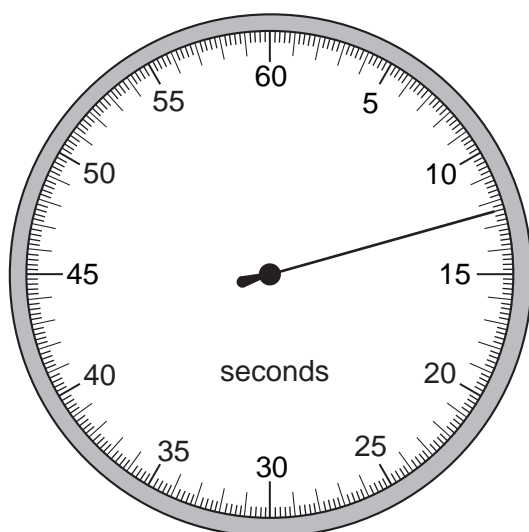

stopwatch at  
end of first  
athlete's run

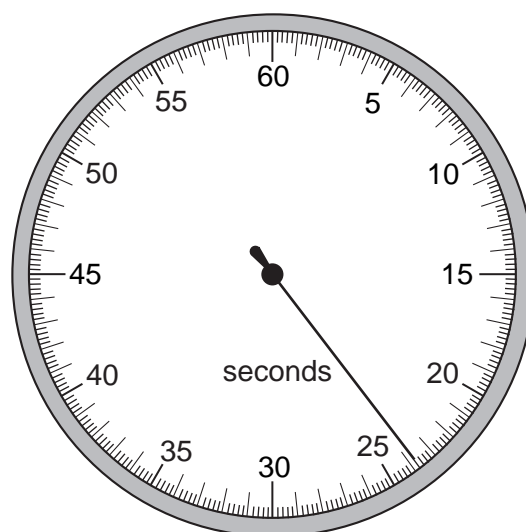

stopwatch at  
end of second  
athlete's run

How long does the second athlete take to run 100 m?

- A** 11.2 s      **B** 11.4 s      **C** 12.4 s      **D** 23.8 s
- 2 A ball is thrown upwards.  
What effect does the force of gravity have on the ball?
- A** It produces a constant acceleration downwards.  
**B** It produces a constant acceleration upwards.  
**C** It produces a decreasing acceleration upwards.  
**D** It produces an increasing acceleration downwards.
- 3 A car accelerates from traffic lights. The graph shows the car's speed plotted against time.

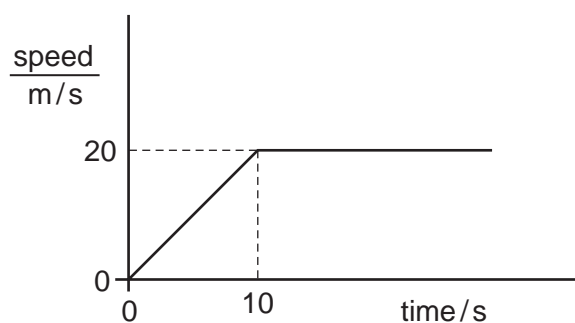

How far does the car travel before it reaches a constant speed?

- A** 10 m      **B** 20 m      **C** 100 m      **D** 200 m

4 Which property of a body can be measured in newtons?

- A density
- B mass
- C volume
- D weight

5 A cup contains hot liquid.

Some of the liquid evaporates as it cools.

What happens to the mass and to the weight of the liquid in the cup as it cools?

	mass	weight
<b>A</b>	decreases	decreases
<b>B</b>	decreases	stays the same
<b>C</b>	stays the same	decreases
<b>D</b>	stays the same	stays the same

6 The diagrams show a rectangular box with inside measurements of 5 cm × 6 cm × 4 cm.

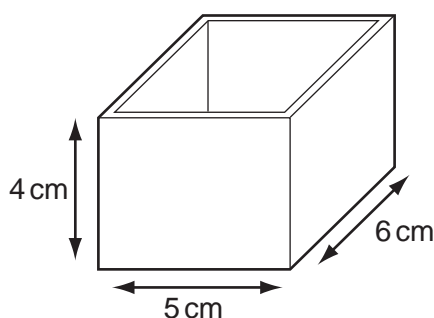

mass = 40 g

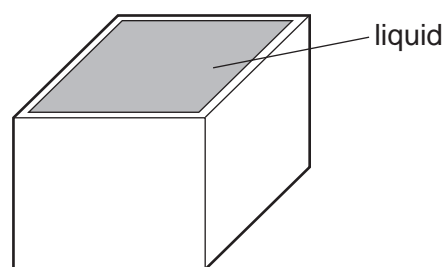

total mass = 220 g

The box has a mass of 40 g when empty. When filled with a liquid, it has a total mass of 220 g.

What is the density of the liquid?

- A  $\frac{220}{(5 \times 6 \times 4)} \text{ g/cm}^3$
- B  $\frac{(220 - 40)}{(5 \times 6 \times 4)} \text{ g/cm}^3$
- C  $\frac{(5 \times 6 \times 4)}{220} \text{ g/cm}^3$
- D  $\frac{(5 \times 6 \times 4)}{(220 - 40)} \text{ g/cm}^3$

4

- 7 Passengers are **not** allowed to stand on the upper deck of double-decker buses.

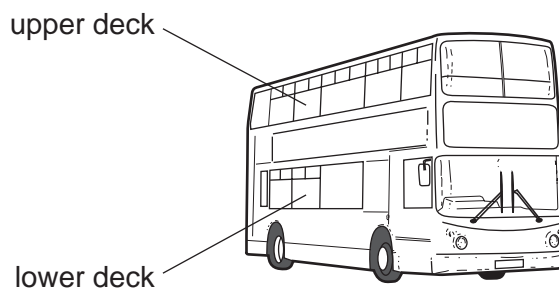

Why is this?

- A They would cause the bus to become unstable.
  - B They would cause the bus to slow down.
  - C They would increase the kinetic energy of the bus.
  - D They would lower the centre of mass of the bus.
- 8 The object in the diagram is acted upon by the two forces shown.

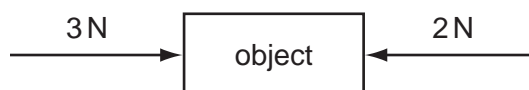

What is the effect of these forces?

- A The object moves to the left with constant speed.
- B The object moves to the left with constant acceleration.
- C The object moves to the right with constant speed.
- D The object moves to the right with constant acceleration.

- 9 The diagram shows a microphone being used in an interview.

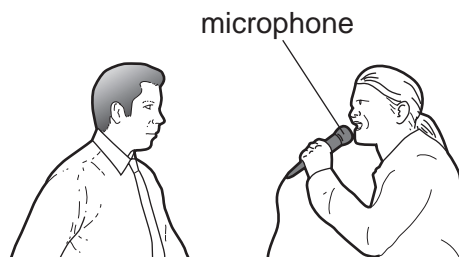

Which energy change takes place in the microphone?

	input energy	output energy
<b>A</b>	chemical	electrical
<b>B</b>	electrical	chemical
<b>C</b>	electrical	sound
<b>D</b>	sound	electrical

- 10 The table shows the times taken for four children to run up a set of stairs.

Which child's power is greatest?

	mass of child / kg	time / s
<b>A</b>	40	10
<b>B</b>	40	20
<b>C</b>	60	10
<b>D</b>	60	20

- 11 A water manometer is used to measure the pressure of a gas supply to a house. It gives a reading of  $h$  cm of water.

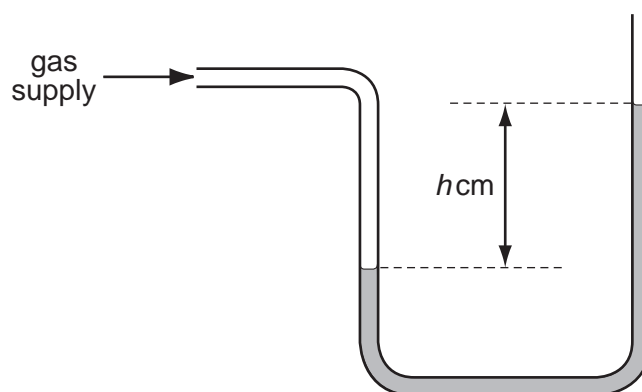

Why is it better to use water rather than mercury in this manometer?

- A  $h$  would be too large if mercury were used.
  - B  $h$  would be too small if mercury were used.
  - C The tube would need to be narrower if mercury were used.
  - D The tube would need to be wider if mercury were used.
- 12 The diagrams show two swimming pools. One contains fresh water and the other contains salt water. Salt water is more dense than fresh water.

At which labelled point is the pressure the greatest?

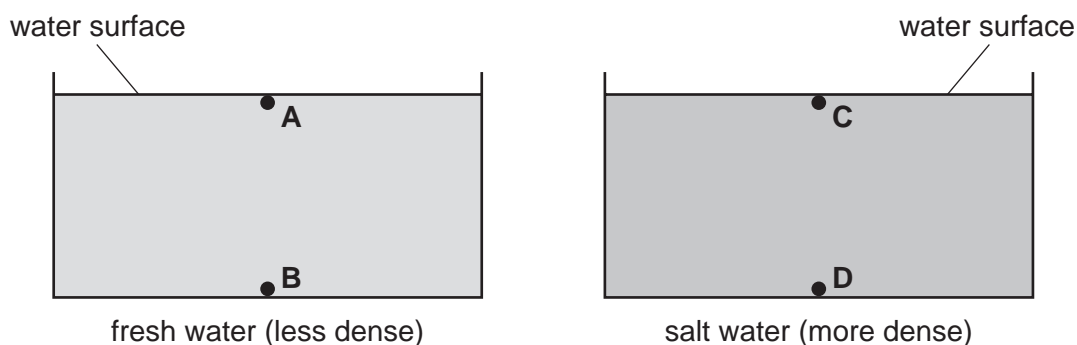

- 13 Brownian motion is observed by looking at smoke particles through a microscope.

How do the smoke particles move in Brownian motion?

- A all in the same direction
- B at random
- C in circles
- D vibrating about fixed points

- 14 A small amount of air is introduced into the vacuum above the mercury in a mercury barometer tube.

The mercury level goes down.

Why does the mercury level go down?

- A The air molecules cool the mercury and make it contract.
  - B The air molecules decrease the pressure above the mercury.
  - C The air molecules heat the mercury and make it expand.
  - D The air molecules increase the pressure above the mercury.
- 15 To mark a temperature scale on a thermometer, standard temperatures known as fixed points are needed.

Which of these is a fixed point?

- A room temperature
  - B the temperature inside a freezer
  - C the temperature of pure melting ice
  - D the temperature of pure warm water
- 16 The table gives the melting points and boiling points of glycerine and benzene.

	melting point	boiling point
glycerine	18 °C	290 °C
benzene	5.4 °C	80 °C

At which temperature will both glycerine and benzene be liquid?

- A 0 °C
- B 50 °C
- C 100 °C
- D 150 °C

17 A beaker contains water at room temperature.

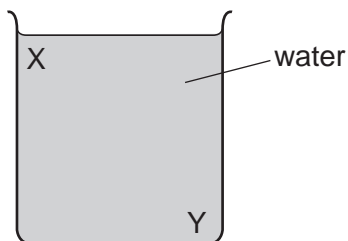

How could a convection current be set up in the water?

- A cool the water at X
- B cool the water at Y
- C stir the water at X
- D stir the water at Y

18 A student warms her hands near a fire.

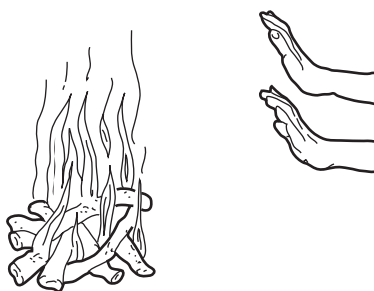

Which waves carry most heat to her hands and are these waves electromagnetic?

	waves	electromagnetic
A	infra-red	no
B	infra-red	yes
C	visible light	no
D	visible light	yes

19 The drawing shows a wave.

Which labelled distance is the wavelength?

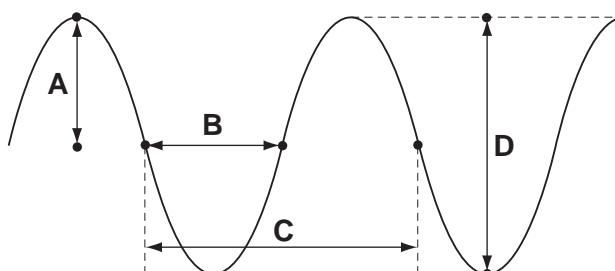



20 Sound waves travel from a point X to another point Y.



Which diagram represents the movement of the air molecules, caused by the sound waves, in the region between X and Y.



21 A ray of light in glass is incident on a boundary with air.

Which path does the ray of light take when the angle of incidence  $i$  is less than the critical angle?

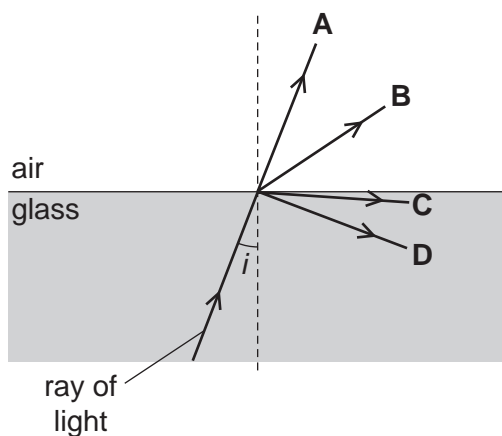

22 An object O is placed in front of a converging lens of focal length  $f$ .

At which point will the top of the image be seen?

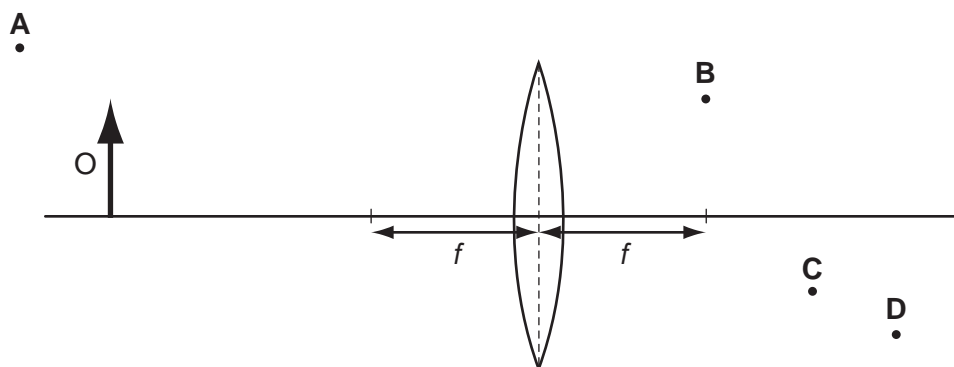

23 Which range of frequencies typically can be heard by a 10 year-old child?

- A 20 Hz – 2000 Hz
- B 20 Hz – 20 000 Hz
- C 200 Hz – 2000 Hz
- D 200 Hz – 20 000 Hz

24 Astronaut 1 uses a hammer to mend a satellite in space. Astronaut 2 is nearby. There is no air in space.

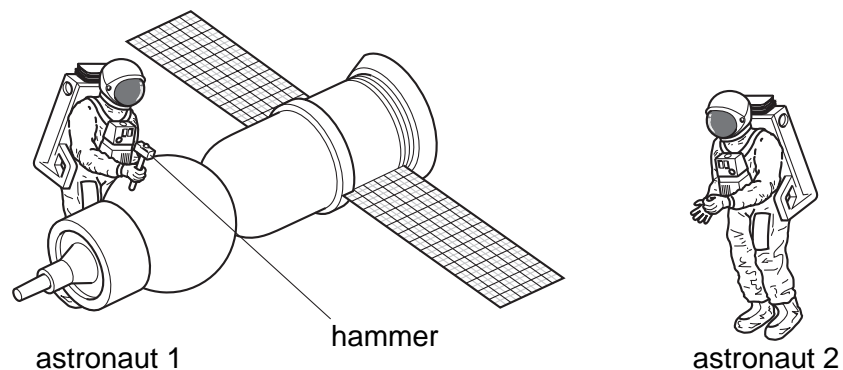

Compared with the sound heard if they were working on Earth, what does astronaut 2 hear?

- A a louder sound
  - B a quieter sound
  - C a sound of the same loudness
  - D no sound at all
- 25 A permanent magnet is brought near to a piece of copper. The copper is not attracted by the magnet.

Why is there no attraction?

- A Copper is ferrous but is only attracted by an electromagnet.
- B Copper is ferrous but is not attracted by any type of magnet.
- C Copper is not ferrous and is only attracted by an electromagnet.
- D Copper is not ferrous and is not attracted by any type of magnet.

- 26 Four plotting compasses are placed in the magnetic field of two identical bar magnets as shown in the diagram.

Which compass is shown pointing in the wrong direction?

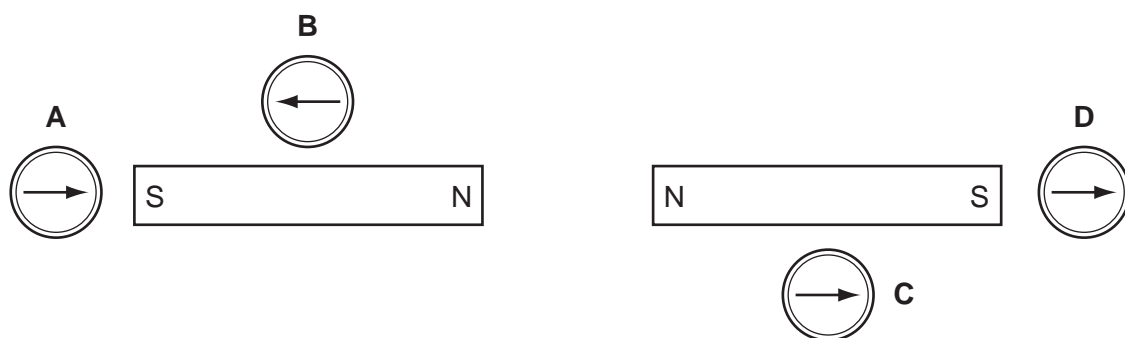

- 27 A pupil measures the potential difference across a device and the current in it.

Which calculation gives the resistance of the device?

- A current + potential difference
  - B current  $\div$  potential difference
  - C potential difference  $\div$  current
  - D potential difference  $\times$  current
- 28 A student uses a length of wire as a resistor. He discovers that the resistance of the wire is too small.

To be certain of making a resistor of higher value, he should use a piece of wire that is

- A longer and thicker.
- B longer and thinner.
- C shorter and thicker.
- D shorter and thinner.

- 29 The diagram shows a battery connected to two identical resistors. Three ammeters  $M_1$ ,  $M_2$  and  $M_3$  are connected in the circuit.

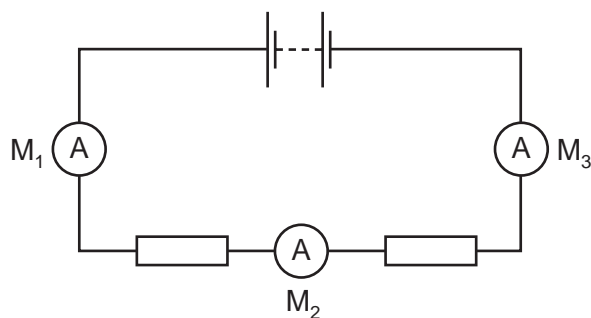

Meter  $M_1$  reads 1.0 A.

What are the readings on  $M_2$  and on  $M_3$ ?

	reading on $M_2$ /A	reading on $M_3$ /A
<b>A</b>	0.5	0.0
<b>B</b>	0.5	0.5
<b>C</b>	0.5	1.0
<b>D</b>	1.0	1.0

- 30 The diagram shows a torch containing two cells, a switch and a lamp.

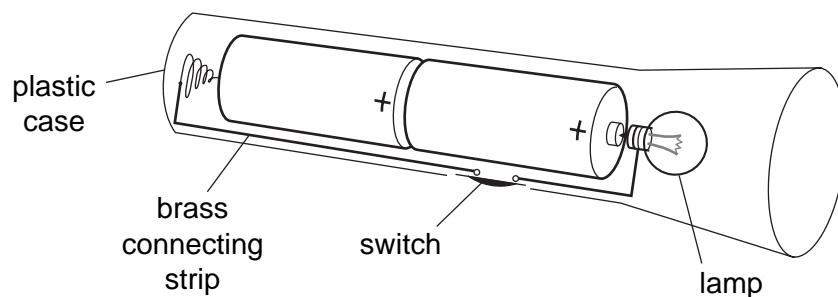

What is the circuit diagram for the torch?

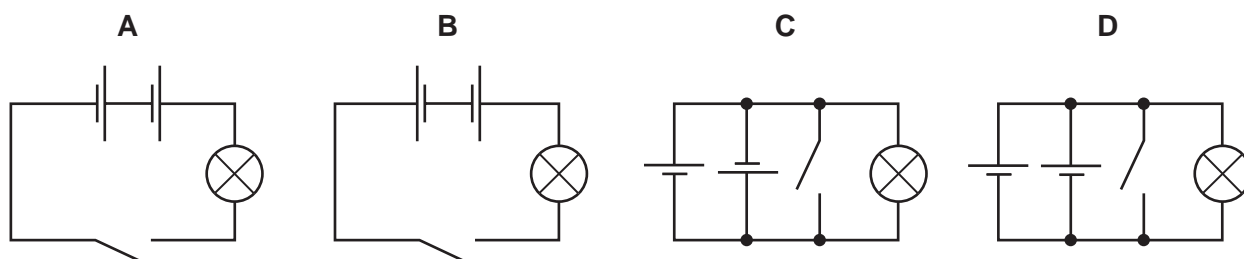

31 An electrical component X is placed in water, as shown.

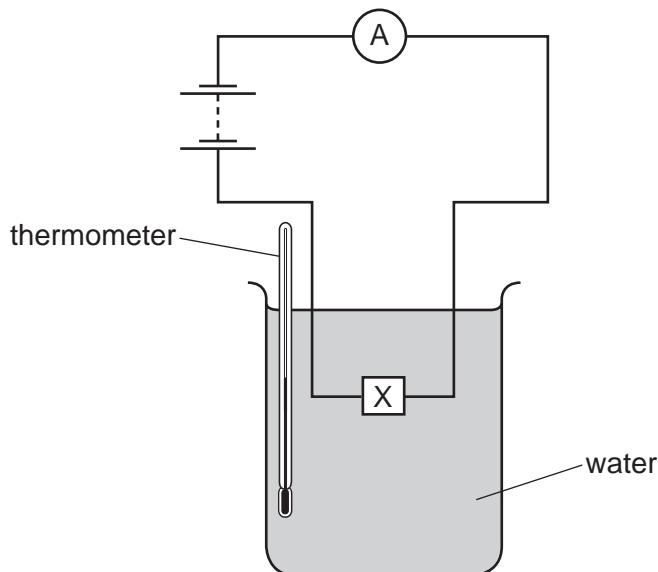

When the temperature of the water is increased, the reading on the ammeter increases.

What is component X?

- A a capacitor
  - B a light-dependent resistor
  - C a relay
  - D a thermistor
- 32 A certain electrical appliance is powered from a mains supply. The appliance normally uses a current of 3 A, but the current briefly rises to 4 A at the instant the appliance is switched on. The cable to the appliance is designed for currents up to 6 A.

The fuses available to protect the cable are rated at 1 A, 3 A, 5 A and 13 A.

Which fuse should be used?

- A 1 A
  - B 3 A
  - C 5 A
  - D 13 A
- 33 On a building site, metal scaffolding is firmly embedded in the damp ground. A builder holds a mains-operated electric drill in one hand. With his other hand he holds on to the scaffolding.

The power cable of the drill is damaged where it enters the metal casing of the drill.

What danger does this present to the builder?

- A A current could pass through the builder and electrocute him.
- B A current in the scaffolding could heat it up and burn him.
- C The large current could blow the fuse and damage the drill.
- D The large current could make the motor spin too quickly.

- 34 Which device is designed to allow a small direct current (d.c.) to control a large direct current (d.c.)?
- A a generator  
 B a motor  
 C a relay  
 D a transformer
- 35 A transformer is to be used to provide a 10V output from a 100V supply.

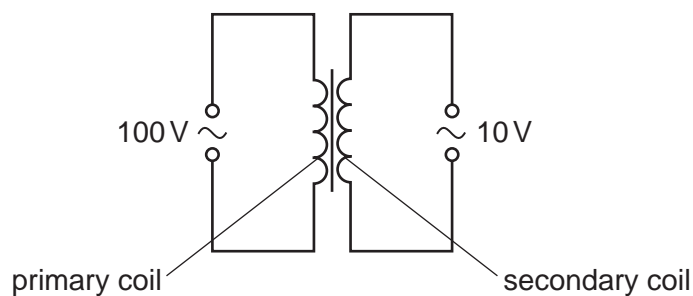

What are suitable numbers of turns for the primary coil and for the secondary coil?

	number of turns on the primary coil	number of turns on the secondary coil
<b>A</b>	100	1000
<b>B</b>	200	110
<b>C</b>	400	490
<b>D</b>	800	80

- 36 The diagram shows a beam of cathode rays entering an electric field.

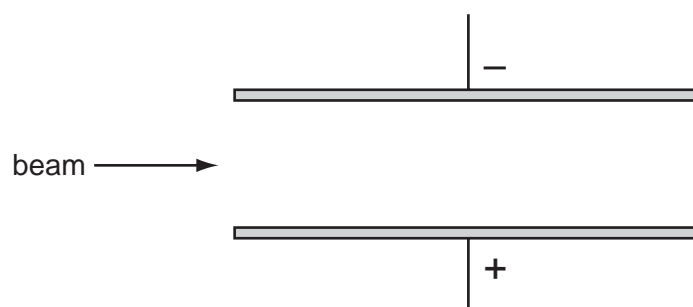

In which direction is the beam deflected by the field?

- A downwards  
 B upwards  
 C into the page  
 D out of the page

- 37 To create cathode rays in a vacuum, what might be a suitable potential difference to connect between the cathode and anode?
- A 6 V a.c.  
 B 6 V d.c.  
 C 600 V a.c.  
 D 600 V d.c.
- 38 Which statement explains the meaning of the half-life of a radioactive substance?
- A half the time taken for half the substance to decay  
 B half the time taken for the substance to decay completely  
 C the time taken for half the substance to decay  
 D the time taken for the substance to decay completely
- 39 The diagram shows the paths of three different types of radiation, X, Y and Z.

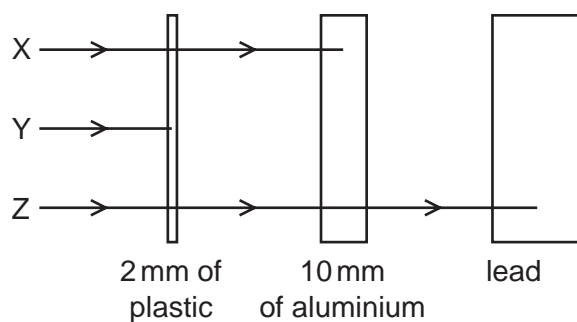

Which row in the table correctly identifies X, Y and Z?

	X	Y	Z
<b>A</b>	$\alpha$ -particles	$\beta$ -particles	$\gamma$ -rays
<b>B</b>	$\beta$ -particles	$\alpha$ -particles	$\gamma$ -rays
<b>C</b>	$\beta$ -particles	$\gamma$ -rays	$\alpha$ -particles
<b>D</b>	$\gamma$ -rays	$\alpha$ -particles	$\beta$ -particles

Question 40 is on the next page.

40 How many neutrons and how many protons are contained in a nucleus of  ${}^{238}_{92}\text{U}$ ?

	neutrons	protons
<b>A</b>	92	146
<b>B</b>	146	92
<b>C</b>	146	238
<b>D</b>	238	92

Permission to reproduce items where third-party owned material protected by copyright is included has been sought and cleared where possible. Every reasonable effort has been made by the publisher (UCLES) to trace copyright holders, but if any items requiring clearance have unwittingly been included, the publisher will be pleased to make amends at the earliest possible opportunity.

University of Cambridge International Examinations is part of the Cambridge Assessment Group. Cambridge Assessment is the brand name of University of Cambridge Local Examinations Syndicate (UCLES), which is itself a department of the University of Cambridge.