



Cambridge International Examinations
Cambridge International General Certificate of Secondary Education

CANDIDATE
NAME

CENTRE
NUMBER

--	--	--	--	--

CANDIDATE
NUMBER

--	--	--	--



PHYSICS

0625/42

Paper 4 Theory (Extended)

February/March 2017

1 hour 15 minutes

Candidates answer on the Question Paper.

No Additional Materials are required.

READ THESE INSTRUCTIONS FIRST

Write your Centre number, candidate number and name on all the work you hand in.

Write in dark blue or black pen.

You may use an HB pencil for any diagrams or graphs.

Do not use staples, paper clips, glue or correction fluid.

DO NOT WRITE IN ANY BARCODES.

Answer **all** questions.

Electronic calculators may be used.

You may lose marks if you do not show your working or if you do not use appropriate units.

Take the weight of 1.0 kg to be 10 N (acceleration of free fall = 10 m/s^2).

At the end of the examination, fasten all your work securely together.

The number of marks is given in brackets [] at the end of each question or part question.

The syllabus is approved for use in England, Wales and Northern Ireland as a Cambridge International Level 1/Level 2 Certificate.

This document consists of **16** printed pages.

- 1 (a) Fig. 1.1 shows the axes used to plot distance-time graphs.



Fig. 1.1

On Fig. 1.1, draw graphs for an object that is

- (i) moving with constant speed, labelling the graph A,
- (ii) moving with decreasing speed, labelling the graph B.

[2]

- (b) Fig. 1.2 shows the axes used to plot speed-time graphs.



Fig. 1.2

On Fig. 1.2, draw graphs for an object that is

- (i) moving with constant acceleration, labelling the graph S,
- (ii) moving with increasing acceleration, labelling the graph T.

[2]

3

- (c) A plane is at rest on an airport runway. The brakes of the plane are released and the engine of the plane provides a constant accelerating force.

Using the following data, calculate the take-off speed of the plane. Ignore any resistive forces.

constant forward force = 56 000 N

mass of plane = 16 000 kg

time of travel along runway = 16 s

speed = [4]

[Total: 8]

- 2 (a) Explain why momentum is a vector quantity.

.....[1]

- (b) The crumple zone at the front of a car is designed to collapse during a collision.

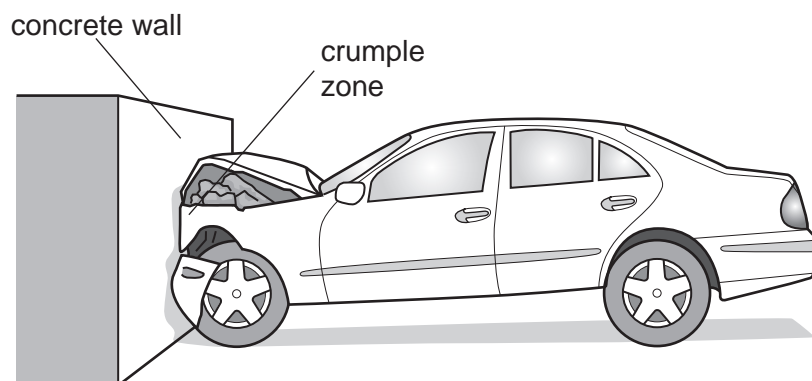

Fig. 2.1

In a laboratory test, a car of mass 1200 kg is driven into a concrete wall, as shown in Fig. 2.1.

A video recording of the test shows that the car is brought to rest in 0.36 s when it collides with the wall. The speed of the car before the collision is 7.5 m/s.

Calculate

- (i) the change of momentum of the car,

change of momentum =[2]

- (ii) the average force acting on the car.

average force =[2]

5

(c) A different car has a mass of 1500 kg. It collides with the same wall and all of the energy transferred during the collision is absorbed by the crumple zone.

(i) The energy absorbed by the crumple zone is 4.3×10^5 J. Show that the speed of the car before the collision is 24 m/s.

[2]

(ii) Suggest what would happen to the car if it is travelling faster than 24 m/s when it hits the wall.

.....

.....[1]

[Total: 8]

3 (a) A stationary object is acted upon by a number of forces.

State the conditions which **must** be true if the object

(i) does not accelerate,

.....[1]

(ii) does not rotate.

.....[1]

(b) Fig. 3.1 shows a boat that has been lifted out of a river. The boat is suspended by two ropes. It is stationary.

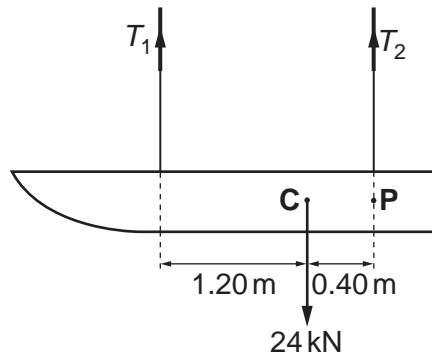

Fig. 3.1 (not to scale)

The weight of the boat, acting at the centre of mass, is 24 kN. The tensions in the ropes are T_1 and T_2 .

Determine

(i) the moment of the weight of the boat about the point P,

moment =[1]

(ii) the tension T_1 ,

$T_1 =$ [3]

(iii) the tension T_2 .

$T_2 =$ [2]

[Total: 8]

- 4 Fig. 4.1 shows a Galilean thermometer. This thermometer is used to measure the approximate temperature of the surrounding air.

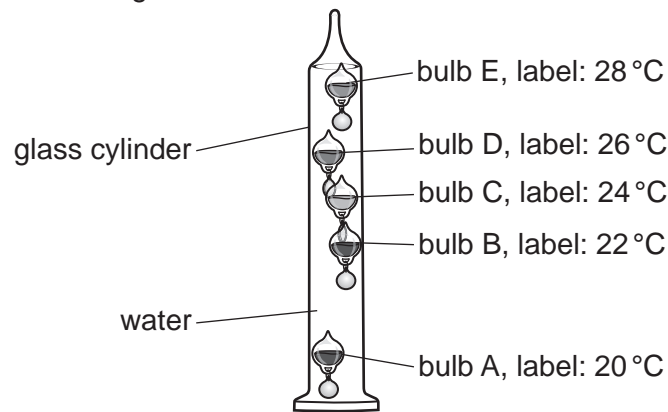

Fig. 4.1

The glass cylinder contains water. When the temperature of the water changes, so does its density.

Each bulb has a label printed with a temperature, as shown in Fig. 4.1. The bulbs have different densities. At 21 °C, only bulb A is at the bottom of the cylinder.

- (a) Explain, in terms of density, why bulb A is at the bottom of the cylinder and the other bulbs are floating.

.....

 [2]

- (b) The temperature of the surrounding air increases to a temperature above 23 °C.

- (i) Suggest **one** reason why there is a delay before the temperature of the water increases to 23 °C.

..... [1]

- (ii) Explain why, after this delay, bulb B sinks. Assume the bulbs do not expand.

.....

 [3]

- (c) Bulbs A, B and C are now at the bottom of the cylinder. Bulbs D and E are floating.

State the possible temperature range of the water in the cylinder.

..... [1]

[Total: 7]

[Turn over

5 (a) (i) State **two** ways in which *evaporation* is different from *boiling*.

1

.....

2

.....

[2]

(ii) Give **one** example of a change of state which does not involve boiling or evaporation.

.....[1]

(b) The graph in Fig. 5.1 shows the variation of temperature with time for a substance that is initially liquid.

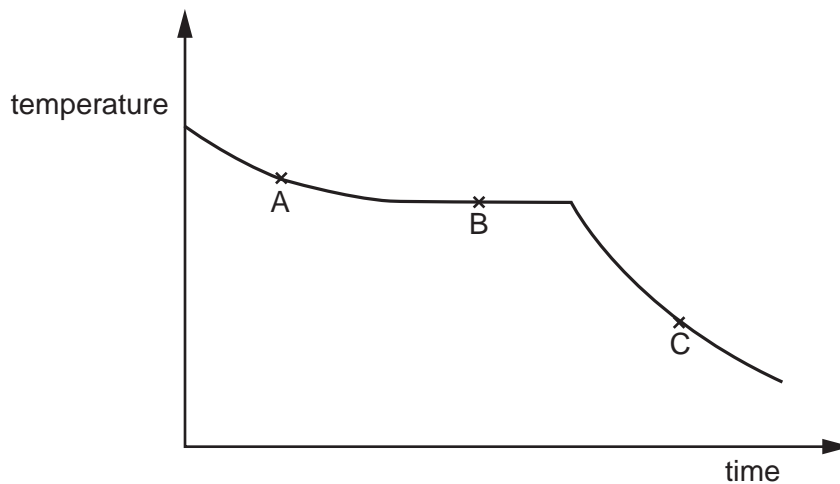

Fig. 5.1

(i) State what is taking place at points A, B and C. You should say what changes of state, if any, are taking place.

point A

point B

point C

[3]

(ii) Suggest why the graph is steeper at point C than at point A.

.....

.....[1]

[Total: 7]

- 7 Fig. 7.1 shows an object and its image formed by a converging lens. One ray from the tip of the object to the tip of the image is shown.

Fig. 7.1 is drawn full size.

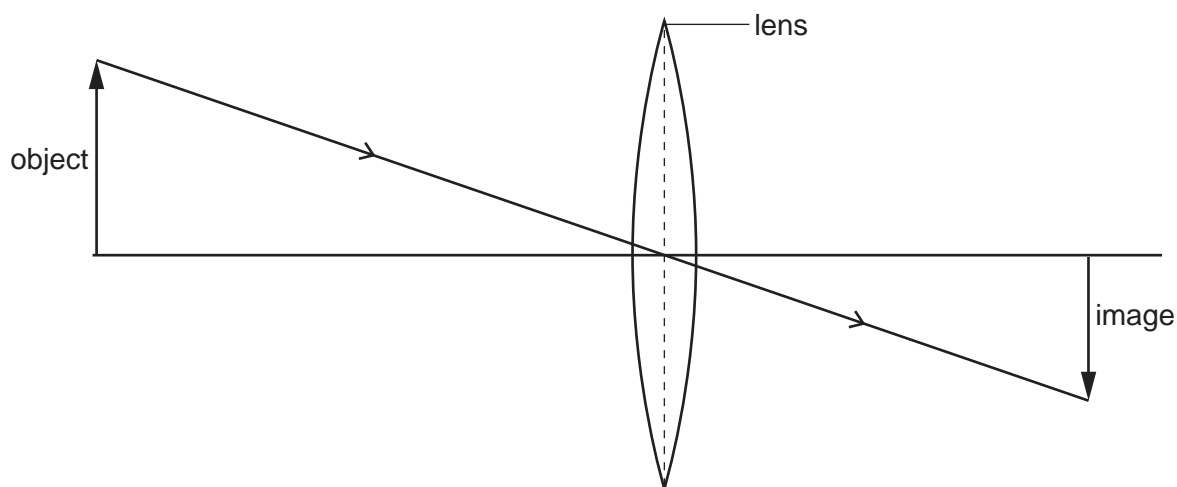

Fig. 7.1

- (a) Place a tick (✓) in **all** boxes that correctly describe the image.

<input type="checkbox"/>	diminished
<input type="checkbox"/>	enlarged
<input type="checkbox"/>	inverted
<input type="checkbox"/>	upright
<input type="checkbox"/>	real
<input type="checkbox"/>	virtual

[2]

- (b) On Fig. 7.1, draw a ray, passing through a principal focus of the lens, from the tip of the object to the tip of the image. Label the principal focus F. [1]

- (c) Use the ray you have drawn in (b) to determine the focal length of the lens.

focal length = [1]

- (d) Draw another ray, **not** passing through a principal focus of the lens, that passes from the tip of the object to the tip of the image. [1]

[Total: 5]

- 8 (a) A transformer consists of two coils of wire wound on a core.
- (i) Suggest the material from which the two coils are made. State the reason for using this material.
- material
- reason
- [2]
- (ii) Suggest the material from which the core is made. State the reason for using this material.
- material
- reason
- [2]

(b) Fig. 8.1 represents the system of transmission of electrical energy from a power station to a home that is a long distance away.

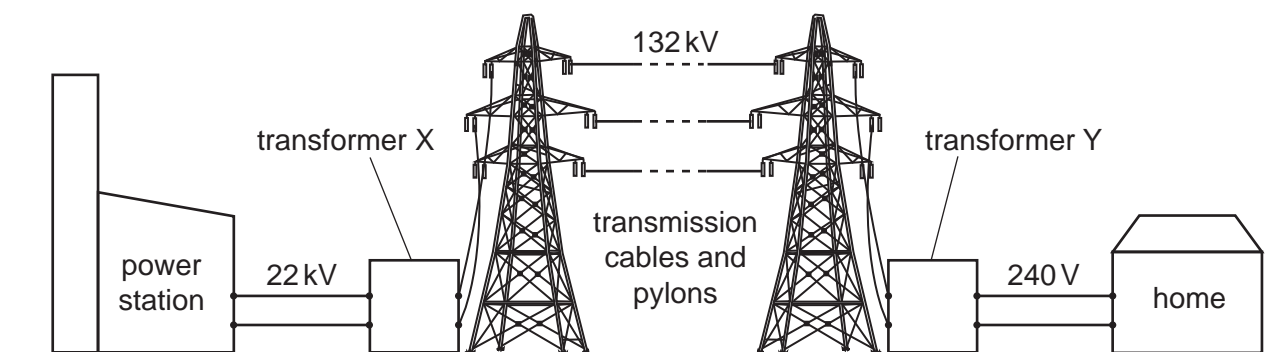

Fig. 8.1

- (i) State the difference between transformer X and transformer Y.
-[1]
- (ii) Explain why a very high voltage is used for transmission over large distances.
-
-
-
-[3]
- (iii) Suggest why the voltage for use by a home consumer is 240 V, and not a much higher value.
-
-[1]

[Total: 9]

[Turn over

9 Fig. 9.1 shows a graph of current against potential difference (p.d.) for a filament lamp.

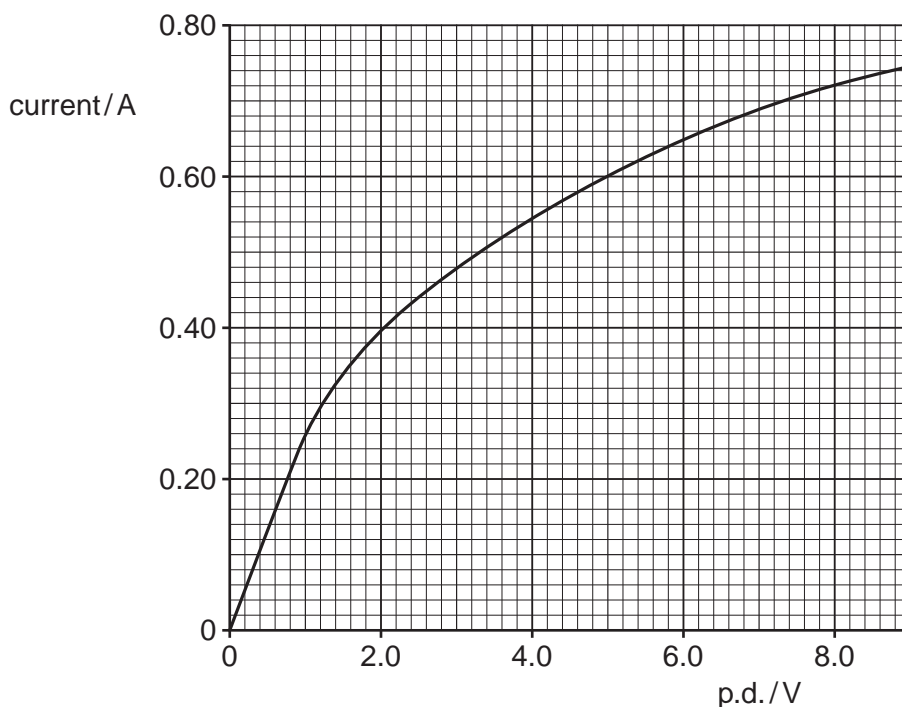

Fig. 9.1

(a) State what happens to the resistance of the filament of the lamp as the p.d. changes

(i) from 0V to 1.0V,

.....[1]

(ii) from 1.0V to 8.0V.

.....[1]

(b) At normal brightness, the p.d. across the lamp is 8.0V.

Calculate, for normal brightness,

(i) the resistance of the lamp,

resistance =[3]

(ii) the power of the lamp.

power =[2]

- (c) Five of these lamps, operating at normal brightness, are connected in parallel to a power supply.

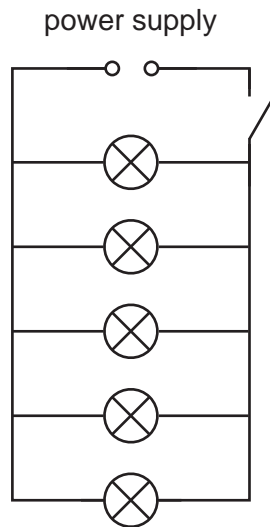

Fig. 9.2

Determine

- (i) the electromotive force (e.m.f.) of the power supply,

e.m.f. =[1]

- (ii) the current from the power supply.

current =[1]

[Total: 9]

- 10 (a) Describe, in terms of particles and the terminals of the battery, the movement of charge in an electric circuit.

.....
 [2]

- (b) Fig. 10.1 shows a lightning flash between a cloud and the ground beneath.

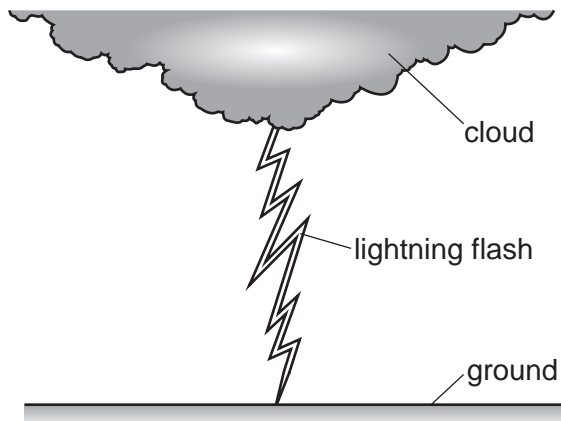

Fig. 10.1

The charge built up on the cloud before the lightning flash is 0.60 C. This charge is completely transferred to the ground by the lightning flash in 5.0×10^{-5} s (0.000050 s).

- (i) Calculate the current between the cloud and the ground.

current = [2]

- (ii) The potential difference (p.d.) between the cloud and the ground during the lightning flash is 2.5×10^8 V.

Calculate the energy transferred during the lightning flash.

energy = [2]

- (iii) Suggest what happens to the energy calculated in (b)(ii).

.....
 [1]

[Total: 7]

- 11 A radioactive source is placed 20 mm from a radiation detector, as shown in Fig. 11.1.

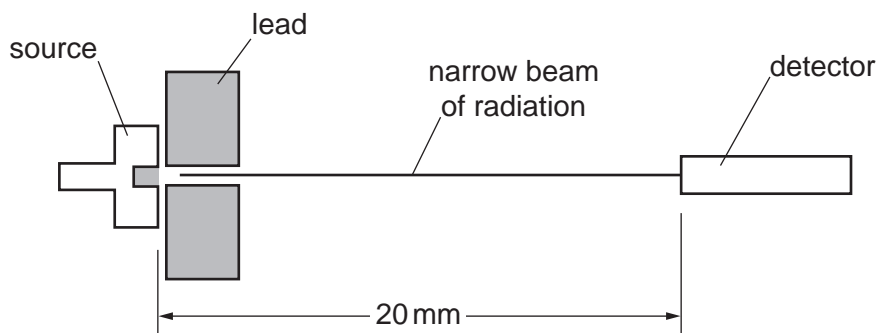

Fig. 11.1 (not to scale)

The initial count rate recorded by the detector is 150 counts/s.

A sheet of paper is placed between the source and the detector. The count rate recorded by the detector falls to 60 counts/s.

With the paper still in place, a magnetic field is set up perpendicular to the direction of the radiation. The count rate recorded by the detector falls to 20 counts/s.

The count rates have not been corrected for background. The background count is measured as 20 counts/s.

- (a) State the evidence that each type of radiation is present in, or absent from, the radiation emitted by the source.

α -particles

.....

β -particles

.....

γ -rays

.....

[5]

- (b) Determine how much of the original count rate of 150 counts/s, if any, is due to each type of radiation.

α -particles counts/s

β -particles counts/s

γ -rays counts/s
[2]

[Total: 7]

Permission to reproduce items where third-party owned material protected by copyright is included has been sought and cleared where possible. Every reasonable effort has been made by the publisher (UCLES) to trace copyright holders, but if any items requiring clearance have unwittingly been included, the publisher will be pleased to make amends at the earliest possible opportunity.

To avoid the issue of disclosure of answer-related information to candidates, all copyright acknowledgements are reproduced online in the Cambridge International Examinations Copyright Acknowledgements Booklet. This is produced for each series of examinations and is freely available to download at www.cie.org.uk after the live examination series.

Cambridge International Examinations is part of the Cambridge Assessment Group. Cambridge Assessment is the brand name of University of Cambridge Local Examinations Syndicate (UCLES), which is itself a department of the University of Cambridge.