



Cambridge IGCSE™ (9–1)

PHYSICS

0972/21

Paper 2 Multiple Choice (Extended)

May/June 2023

45 minutes

You must answer on the multiple choice answer sheet.

You will need: Multiple choice answer sheet
Soft clean eraser
Soft pencil (type B or HB is recommended)

INSTRUCTIONS

- There are **forty** questions on this paper. Answer **all** questions.
- For each question there are four possible answers **A**, **B**, **C** and **D**. Choose the **one** you consider correct and record your choice in soft pencil on the multiple choice answer sheet.
- Follow the instructions on the multiple choice answer sheet.
- Write in soft pencil.
- Write your name, centre number and candidate number on the multiple choice answer sheet in the spaces provided unless this has been done for you.
- Do **not** use correction fluid.
- Do **not** write on any bar codes.
- You may use a calculator.
- Take the weight of 1.0 kg to be 9.8 N (acceleration of free fall = 9.8 m/s^2).

INFORMATION

- The total mark for this paper is 40.
- Each correct answer will score one mark.
- Any rough working should be done on this question paper.

This document has **16** pages. Any blank pages are indicated.



2

- 1 Which vector diagram correctly shows the force Z as the resultant of forces X and Y ?

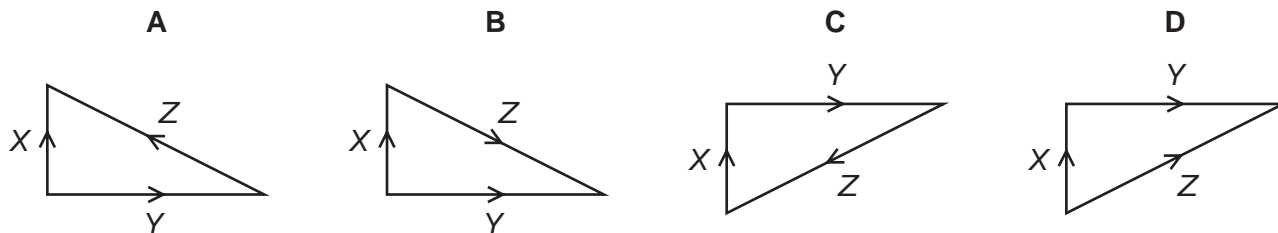

- 2 An object falls towards the surface of the Earth.

The object is falling at its terminal velocity.

Which statement is correct?

- A** There is air resistance and the acceleration of the object is negative.
B There is air resistance and the acceleration of the object is zero.
C There is no air resistance and the acceleration of the object is negative.
D There is no air resistance and the acceleration of the object is zero.
- 3 The graph represents the motion of a vehicle.

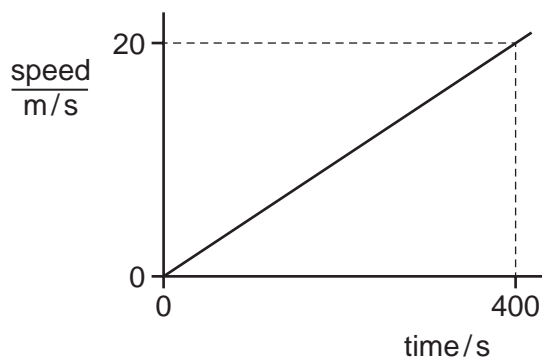

What is the distance travelled by the vehicle in 400 s?

- A** 20 m **B** 400 m **C** 4000 m **D** 8000 m
- 4 On the Earth, a spring stretches by 5.0 cm when a mass of 3.0 kg is suspended from one end.

The gravitational field strength on the Moon is $\frac{1}{6}$ of that on the Earth.

Which mass, on the Moon, would stretch the spring by the same extension?

- A** 0.50 kg **B** 3.0 kg **C** 5.0 kg **D** 18 kg

- 5 A shopkeeper pours rice into a dish that hangs from a spring balance. He records the reading.

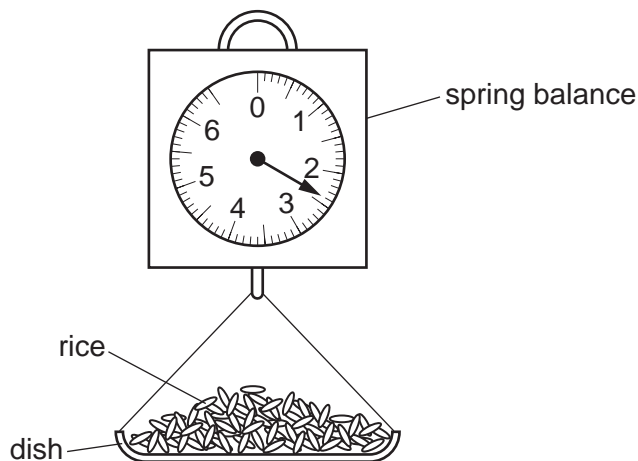

A customer buys some pasta. The shopkeeper notices that the reading on the spring balance, with just pasta in the dish, is the same as it was with just rice in the dish.

Which quantity **must** be the same for the rice and for the pasta?

- A density
 - B temperature
 - C volume
 - D weight
- 6 A student determines the density of an irregularly shaped stone. The stone is slowly lowered into a measuring cylinder partly filled with water.

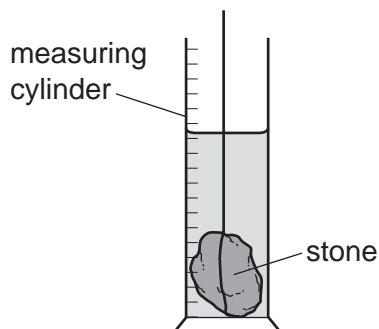

Which other apparatus does the student need to calculate the density of the irregularly shaped stone?

- A a balance
- B a thermometer
- C a metre rule
- D a stop-watch

4

- 7 A train is travelling horizontally in a straight line. A book is on a table in the train.

The diagram shows all the forces acting on the book.

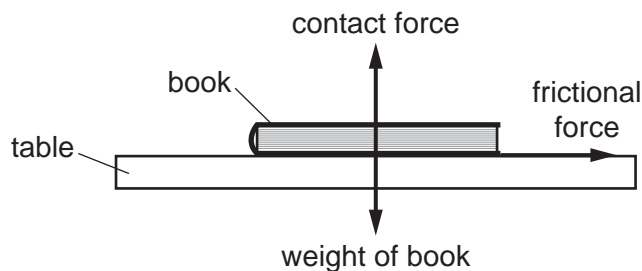

How is the train moving?

- A accelerating to the left of the diagram
 B accelerating to the right of the diagram
 C moving at uniform speed to the left of the diagram
 D moving at uniform speed to the right of the diagram
- 8 The diagrams show four beams, each of negligible weight and freely pivoted.

Which beam is **not** in equilibrium?

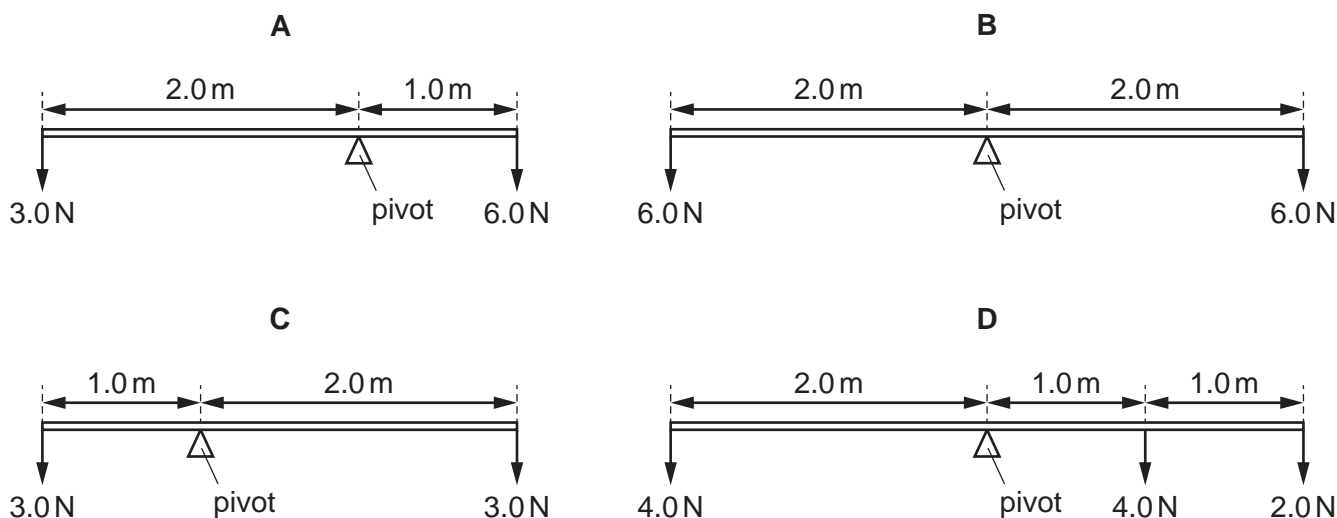

- 9 An object of mass 1.2 kg is moving with a velocity of 2.0 m/s when it is acted on by a force of 4.0 N. The velocity of the object increases to 5.0 m/s in the same direction.

For which period of time does the force act on the object?

- A 0.90 s B 1.1 s C 1.5 s D 3.6 s

10 Which row about the change of energy in the energy store must be correct?

	process	energy store	change of energy in store
A	water pumped up to a high-altitude dam	gravitational potential energy of water	increases
B	water pumped up to a high-altitude dam	kinetic energy of water	decreases
C	air passes through a wind turbine	gravitational potential energy of air	increases
D	air passes through a wind turbine	kinetic energy of air	increases

11 A woman of mass 50 kg has 81 J of kinetic energy.

What is her speed?

- A** 1.3 m/s **B** 1.6 m/s **C** 1.8 m/s **D** 3.2 m/s

12 A child runs up a set of stairs four times. The time taken for each run is recorded.

Which time is measured when the child's useful power is greatest?

- A** 10 s **B** 20 s **C** 30 s **D** 40 s

13 A dam holds water in a reservoir. The height of the water in the reservoir is 15 m.

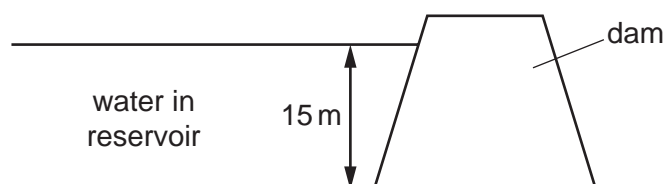

The density of water is 1000 kg/m^3 .

What is the pressure due to the water at the bottom of the dam?

- A** 6.8 Pa **B** 1500 Pa **C** 15 000 Pa **D** 150 000 Pa

14 A student uses a microscope to observe pollen moving on the surface of water.

Which statement describes the reason for this movement?

- A** Water molecules are moved by microscopic pollen particles.
B Water molecules are moved by pollen molecules.
C Microscopic pollen particles are moved by water molecules.
D Pollen molecules are moved by water molecules.

15 Which statements about evaporation of water are correct?

- 1 Evaporation causes the remaining liquid to cool.
- 2 During evaporation, the more energetic particles escape from the surface of the liquid.
- 3 Evaporation only happens at 100°C .

A 1, 2 and 3 **B** 1 and 2 only **C** 1 and 3 only **D** 2 and 3 only

16 Some hot water is sealed inside a metal can. The can is in a vacuum in outer space. The hot water slowly cools down.

How does the thermal energy escape into space?

- A** by conduction then convection
- B** by conduction then radiation
- C** by evaporation then convection
- D** by evaporation then radiation

17 The diagrams show graphs of displacement against time for four waves. All the graphs are drawn to the same scale.

Which wave has the largest amplitude and the highest frequency?

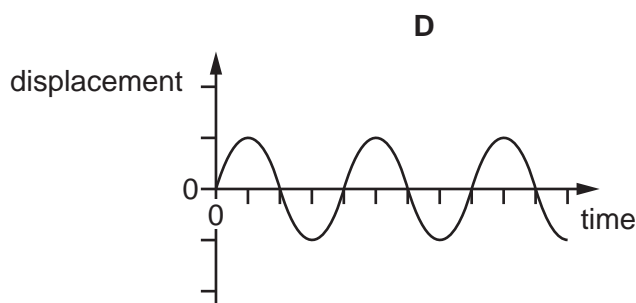
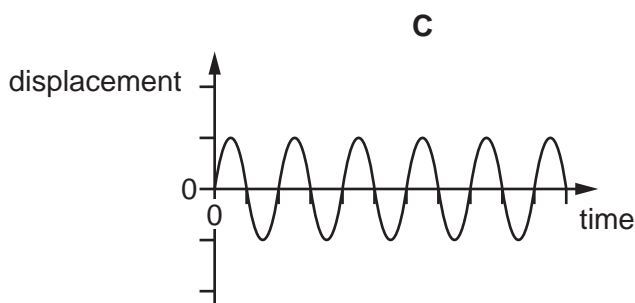
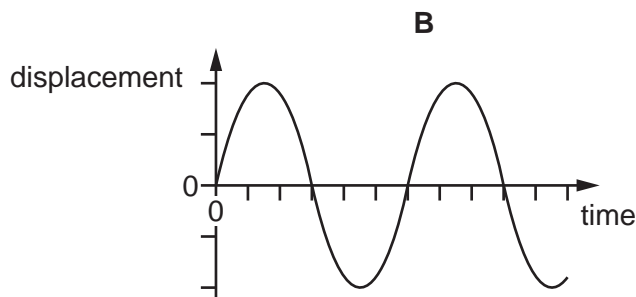
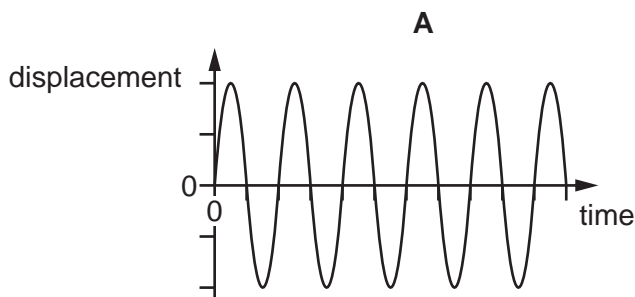

- 18 The diagram shows a ray of light entering a glass block.

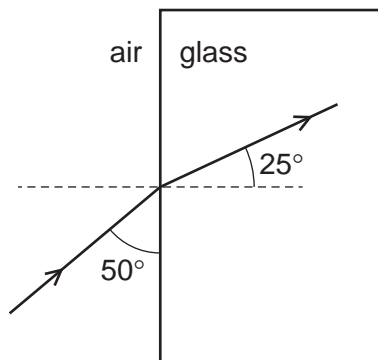

Which calculation gives the refractive index of the glass?

- A $\frac{\sin 40^\circ}{\sin 25^\circ}$ B $\frac{\sin 40^\circ}{\sin 65^\circ}$ C $\frac{\sin 50^\circ}{\sin 25^\circ}$ D $\frac{\sin 50^\circ}{\sin 65^\circ}$
- 19 An object O is placed at point P near to a thin converging lens. The diagram shows three rays from the top of O passing through the lens. Each point F is one focal length from the centre of the lens. Each point 2F is two focal lengths from the centre of the lens.

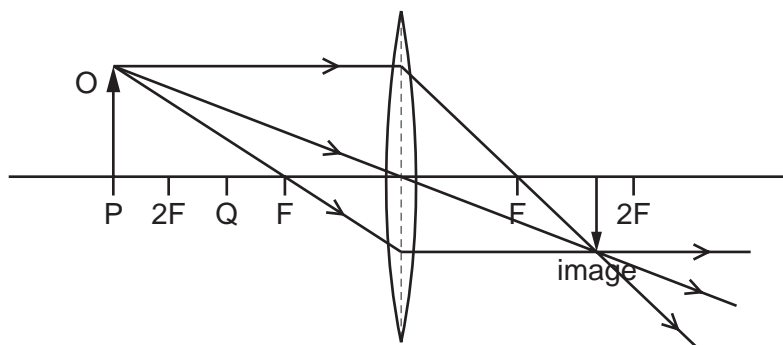

The object O is moved to point Q on the diagram.

Which type of image is produced when the object O is at point Q?

- A inverted and the same size as the object
 B inverted and enlarged
 C upright and the same size as the object
 D upright and enlarged

20 Which diagram shows the dispersion of white light by a glass prism?

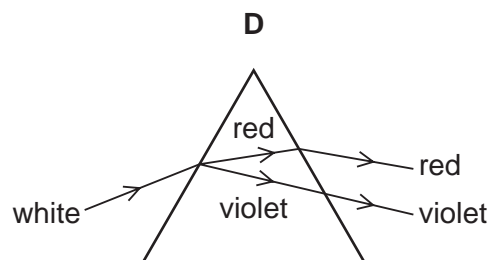
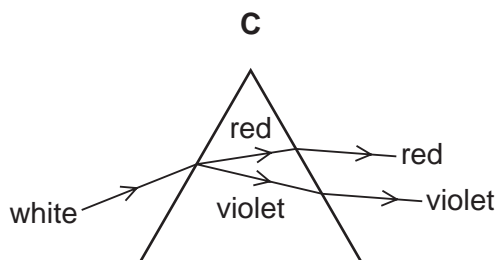
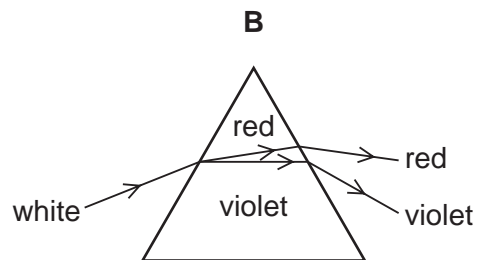
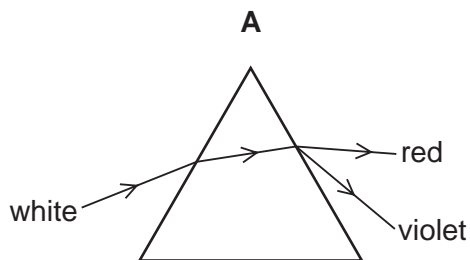

21 Visible light has wavelengths in the range $4.0 \times 10^{-7} \text{ m}$ to $7.0 \times 10^{-7} \text{ m}$.

What is the range of the frequencies of visible light?

- A 0.12 Hz to 0.21 Hz
- B 120 Hz to 210 Hz
- C $4.3 \times 10^{11} \text{ Hz}$ to $7.5 \times 10^{11} \text{ Hz}$
- D $4.3 \times 10^{14} \text{ Hz}$ to $7.5 \times 10^{14} \text{ Hz}$

22 Student X fires a starting pistol which produces smoke and sound. Student Y is standing 100 m away and sees the smoke the instant it is produced. The speed of sound in air is 340 m/s.

What is the time delay between student Y seeing the smoke and hearing the sound?

- A 0.29 s
- B 0.59 s
- C 1.7 s
- D 3.4 s

23 An unmagnetised piece of soft iron is placed close to a strong permanent magnet, as shown.

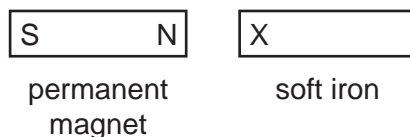

What is the induced polarity of end X of the soft iron and in which direction does the magnetic force act on the soft iron?

	polarity of end X	direction of force on the soft iron
A	N	to the left
B	N	to the right
C	S	to the left
D	S	to the right

24 A plastic rod is rubbed with a cloth.

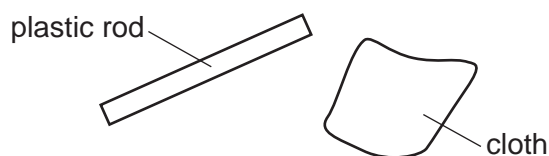

The rod and the cloth both become charged as electrons move between them.

The rod becomes negatively charged.

Which diagram shows how the rod becomes negatively charged and shows the final charge on the cloth?

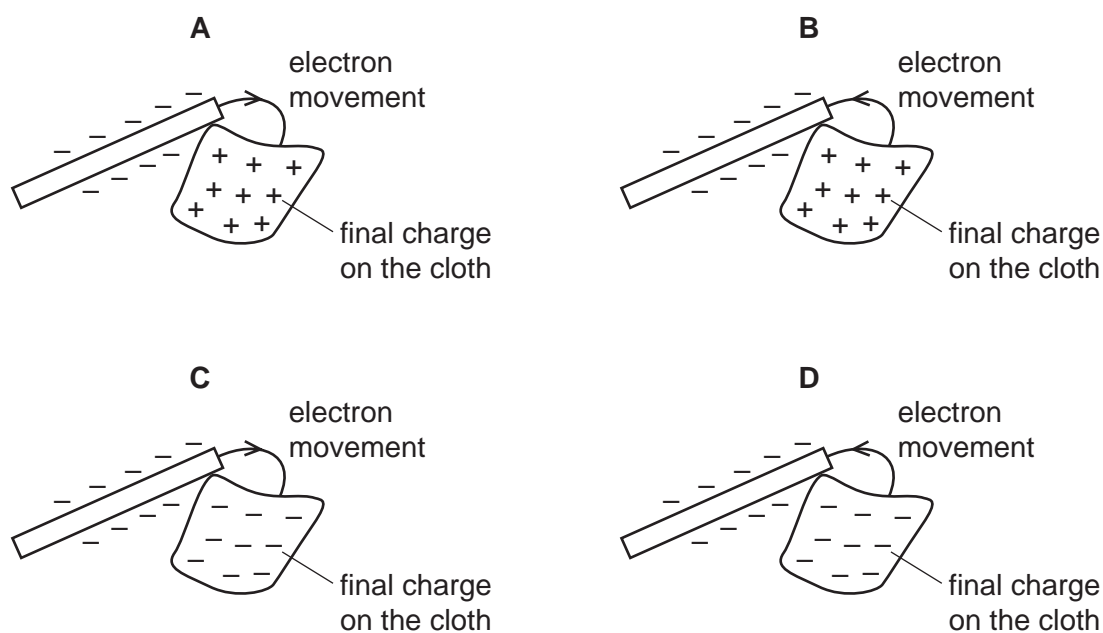

25 A wire has a uniform circular cross-sectional area.

Which statement is correct?

- A The resistance of the wire is directly proportional to its cross-sectional area and inversely proportional to its diameter.
- B The resistance of the wire is directly proportional to its cross-sectional area and inversely proportional to its length.
- C The resistance of the wire is directly proportional to its length and inversely proportional to its cross-sectional area.
- D The resistance of the wire is directly proportional to its length and inversely proportional to its diameter.

26 The diagram shows the current–voltage graph for a metal wire.

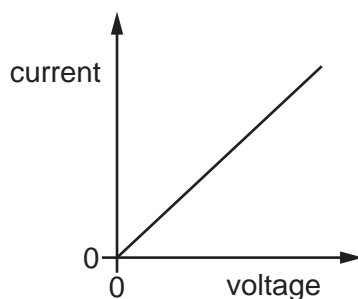

What can be deduced from the graph?

- A As voltage increases, the temperature of the wire increases.
 - B As voltage increases, the temperature of the wire decreases.
 - C As voltage increases, the resistance of the wire increases.
 - D As voltage increases, the resistance of the wire remains constant.
- 27 A battery is connected to a circuit. It is switched on for 1.0 minute. During that time, there is a current of 0.40 A in the circuit and the battery supplies a total of 48 J of energy.

Which row gives the charge that passes and the electromotive force (e.m.f.) of the battery?

	charge that passes in 1.0 minute/C	e.m.f. of the battery/V
A	0.40	2.0
B	0.40	120
C	24	2.0
D	24	120

- 28 The circuit diagram shows two identical lamps connected in parallel to a cell. Three ammeters, X, Y and Z, are also connected in the circuit, as shown.

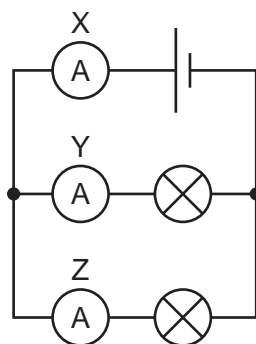

Which statement about the current in X is correct?

- A** It is equal to the current in Y and to the current in Z.
B It is less than either the current in Y or the current in Z.
C It is equal to the sum of the current in Y and the current in Z.
D It is equal to the difference between the current in Y and the current in Z.
- 29 A student connects the circuit shown.

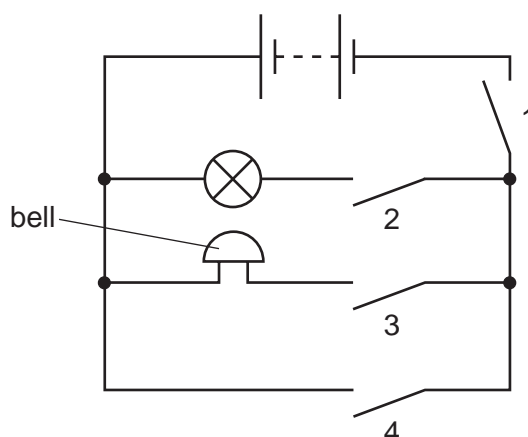

Which switches must be closed for the bell to ring without lighting the lamp?

- A** 1 and 2 only **B** 1 and 3 only **C** 1, 3 and 4 **D** 2, 3 and 4

30 The diagram shows an a.c. generator.

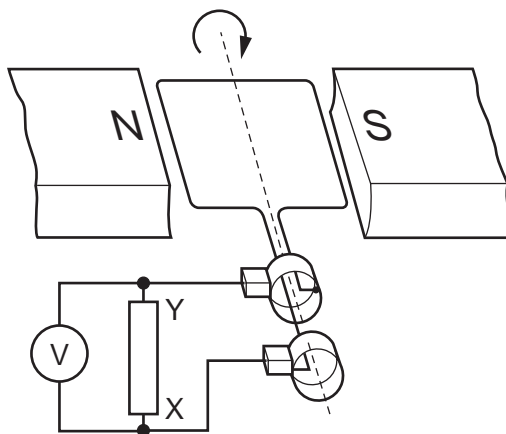

The graph shows the potential difference (p.d.) between points X and Y plotted against time. A positive value of p.d. indicates that X is more positive than Y.

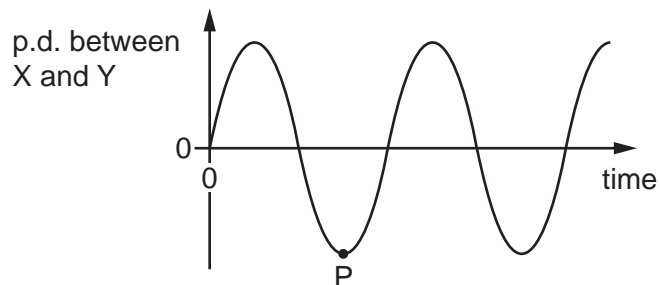

Which diagram shows the position of the coil at point P on the graph?

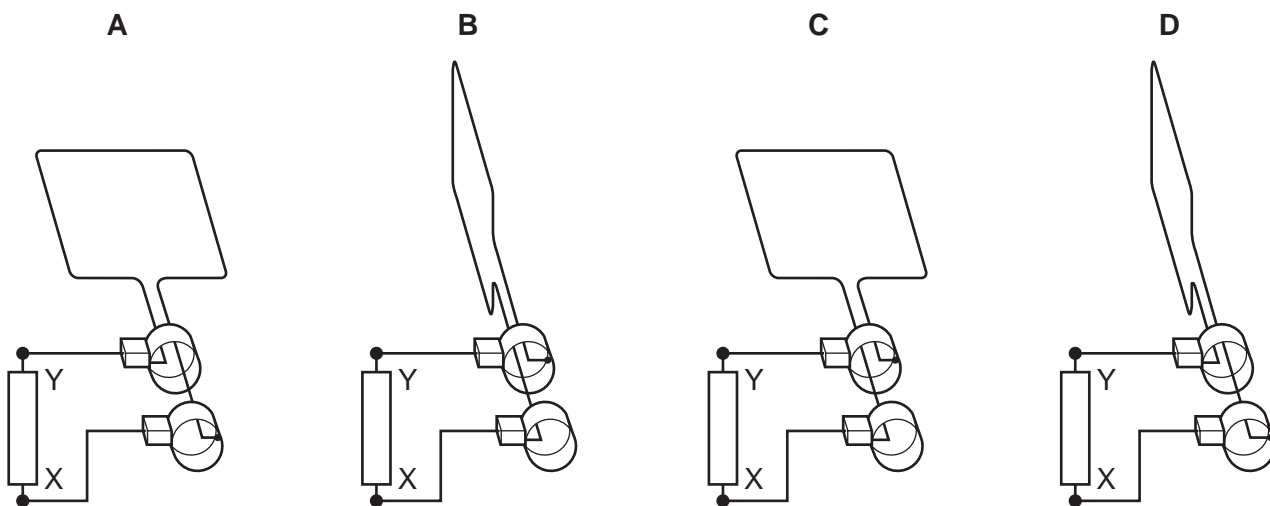

31 An electron moves into a uniform magnetic field.

The arrow shows the initial direction of motion of the electron.

The direction of the magnetic field is into the plane of the page.

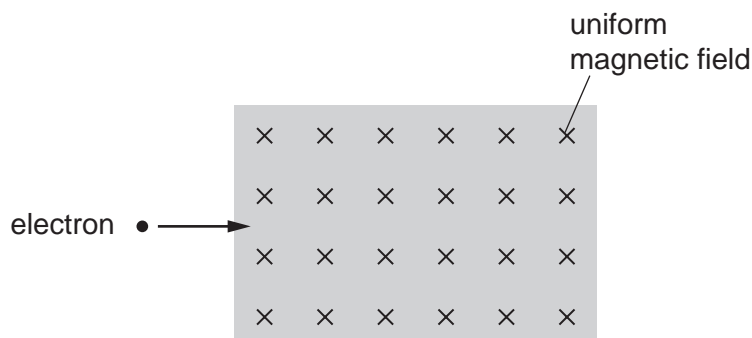

In which direction does a force act on the electron when it enters the magnetic field?

- A into the page
- B out of the page
- C towards the bottom of the page
- D towards the top of the page

32 Which statement about a transformer is correct?

- A There is an alternating current in the iron core from the primary coil to the secondary coil.
- B An alternating current in the iron core induces an alternating current in the secondary coil.
- C An alternating current in the primary coil induces a direct current in the secondary coil.
- D An alternating current in the primary coil induces an alternating voltage across the secondary coil.

33 How are positive and negative ions formed from atoms?

	positive ion	negative ion
A	add positive charge to the nucleus	add an electron to the atom
B	add positive charge to the nucleus	remove positive charge from the nucleus
C	remove an electron from the atom	add an electron to the atom
D	remove an electron from the atom	remove positive charge from the nucleus

- 34 A nucleus of element X is represented as ${}_{26}^{56}\text{X}$.

Which is an isotope of element X?

- A ${}_{56}^{26}\text{X}$ B ${}_{26}^{54}\text{X}$ C ${}_{24}^{56}\text{X}$ D ${}_{28}^{54}\text{X}$

- 35 A radioactive source is placed near a detector connected to a counter.

210 counts are recorded by the counter in 3 minutes.

The background count rate is 20 counts per minute (cpm).

What is the corrected count rate for the radioactive source?

- A 50 cpm B 70 cpm C 190 cpm D 270 cpm

- 36 The background count rate measured by a radiation counter is 40 counts per minute (cpm).

With the counter close to a radioactive source, the counter reading is 960 cpm.

The half-life of the source is 20 minutes.

What is the counter reading one hour later?

- A 115 cpm B 120 cpm C 155 cpm D 160 cpm

- 37 Which planet in our Solar System is nearest to the Sun and what is the nature of the planet?

	planet	nature
A	Mercury	rocky
B	Mercury	gaseous
C	Venus	rocky
D	Venus	gaseous

- 38 A space station orbits the Earth at a distance of 7000 km from the Earth's centre. It makes 15 orbits in every 24-hour period.

What is the speed of the space station in its orbit?

- A 2900 km/h B 4400 km/h C 8800 km/h D 27 000 km/h

- 39 Which nuclear reaction powers a stable star?
- A nuclear fission of nuclei producing hydrogen
 - B nuclear fission of a uranium nucleus into a krypton nucleus and a barium nucleus
 - C nuclear fusion of a krypton nucleus and a barium nucleus into a uranium nucleus
 - D nuclear fusion of hydrogen nuclei producing helium
- 40 Which stages in the life cycle of a star are listed in the order that they occur?
- A interstellar dust cloud → stable star → protostar
 - B protostar → red giant → stable star
 - C red giant → white dwarf → protostar
 - D stable star → red giant → white dwarf

BLANK PAGE

Permission to reproduce items where third-party owned material protected by copyright is included has been sought and cleared where possible. Every reasonable effort has been made by the publisher (UCLES) to trace copyright holders, but if any items requiring clearance have unwittingly been included, the publisher will be pleased to make amends at the earliest possible opportunity.

To avoid the issue of disclosure of answer-related information to candidates, all copyright acknowledgements are reproduced online in the Cambridge Assessment International Education Copyright Acknowledgements Booklet. This is produced for each series of examinations and is freely available to download at www.cambridgeinternational.org after the live examination series.

Cambridge Assessment International Education is part of Cambridge Assessment. Cambridge Assessment is the brand name of the University of Cambridge Local Examinations Syndicate (UCLES), which is a department of the University of Cambridge.