

Please check the examination details below before entering your candidate information

Candidate surname					Other names				
Centre Number				Candidate Number					
<input type="text"/>	<input type="text"/>	<input type="text"/>	<input type="text"/>	<input type="text"/>	<input type="text"/>	<input type="text"/>	<input type="text"/>	<input type="text"/>	<input type="text"/>

Pearson Edexcel International GCSE (9–1)

Time 2 hours	Paper reference	4CH1/1CR 4SD0/1CR
--------------	-----------------	-------------------

Chemistry

UNIT: 4CH1
Science (Double Award) 4SD0
PAPER: 1CR

<p>You must have: Calculator, ruler</p>	Total Marks
---	-------------

Instructions

- Use **black** ink or ball-point pen.
- **Fill in the boxes** at the top of this page with your name, centre number and candidate number.
- Answer **all** questions.
- Answer the questions in the spaces provided
– *there may be more space than you need.*
- Show all the steps in any calculations and state the units.

Information

- The total mark for this paper is 110.
- The marks for **each** question are shown in brackets
– *use this as a guide as to how much time to spend on each question.*

Advice

- Read each question carefully before you start to answer it.
- Write your answers neatly and in good English.
- Try to answer every question.
- Check your answers if you have time at the end.

Turn over ►

P70946A

©2022 Pearson Education Ltd.

Q:1/1/1/



Pearson

The Periodic Table of the Elements

1	2	3	4	5	6	7	0										
7 Li lithium 3	9 Be beryllium 4	11 Na sodium 11	12 C carbon 6	13 Al aluminium 13	14 N nitrogen 7	15 P phosphorus 15	16 O oxygen 8	17 F fluorine 9	18 Ne neon 10								
19 K potassium 19	20 Ca calcium 20	23 Sc scandium 21	24 Ti titanium 22	25 V vanadium 23	26 Cr chromium 24	27 Mn manganese 25	28 Fe iron 26	29 Co cobalt 27	30 Ni nickel 28	31 Cu copper 29	32 Zn zinc 30	33 Ga gallium 31	34 Ge germanium 32	35 As arsenic 33	36 Se selenium 34	37 Br bromine 35	38 Kr krypton 36
39 Rb rubidium 37	40 Sr strontium 38	45 Y yttrium 39	48 Zr zirconium 40	51 Nb niobium 41	52 Mo molybdenum 42	55 Tc technetium 43	56 Ru ruthenium 44	59 Rh rhodium 45	63.5 Pd palladium 46	65 Ag silver 47	70 Cd cadmium 48	73 In indium 49	75 Sb antimony 51	79 Te tellurium 52	80 I iodine 53	84 Xe xenon 54	
55 Cs caesium 55	56 Ba barium 56	89 La* lanthanum 57	91 Hf hafnium 72	93 Ta tantalum 73	96 W tungsten 74	101 Re rhenium 75	101 Os osmium 76	103 Ir iridium 77	106 Pt platinum 78	108 Au gold 79	112 Hg mercury 80	115 Tl thallium 81	119 Pb lead 82	122 Bi bismuth 83	127 Po polonium 84	131 At astatine 85	136 Rn radon 86
[223] Fr francium 87	[226] Ra radium 88	[227] Ac* actinium 89	[261] Rf rutherfordium 104	[262] Db dubnium 105	[266] Sg seaborgium 106	[264] Bh bohrium 107	[277] Hs hassium 108	[268] Mt meitnerium 109	[271] Ds darmstadtium 110	[272] Rg roentgenium 111	Elements with atomic numbers 112–116 have been reported but not fully authenticated						

1	H	1
	hydrogen	

relative atomic mass
atomic symbol
name
atomic (proton) number

* The lanthanoids (atomic numbers 58–71) and the actinoids (atomic numbers 90–103) have been omitted.

The relative atomic masses of copper and chlorine have not been rounded to the nearest whole number.

DO NOT WRITE IN THIS AREA

DO NOT WRITE IN THIS AREA

DO NOT WRITE IN THIS AREA



DO NOT WRITE IN THIS AREA

DO NOT WRITE IN THIS AREA

DO NOT WRITE IN THIS AREA

BLANK PAGE



Answer ALL questions.

Some questions must be answered with a cross in a box ☒. If you change your mind about an answer, put a line through the box ☒ and then mark your new answer with a cross ☒.

- 1 (a) The diagram represents an atom of an element.

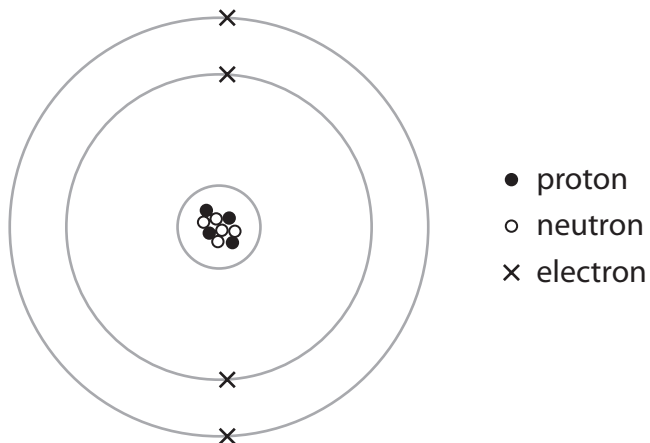

Use numbers from the box to complete the table.

You may use each number once, more than once or not at all.

2	4	5	9	10
---	---	---	---	----

(4)

Atomic number of this atom	
Mass number of this atom	
Period number of this element	
Number of electrons in the 2+ ion formed from this atom	

DO NOT WRITE IN THIS AREA

DO NOT WRITE IN THIS AREA

DO NOT WRITE IN THIS AREA



(b) In terms of sub-atomic particles, state a similarity and a difference for isotopes of the same element.

(2)

similarity

.....
.....

difference

.....
.....

(Total for Question 1 = 6 marks)

DO NOT WRITE IN THIS AREA

DO NOT WRITE IN THIS AREA

DO NOT WRITE IN THIS AREA



2 This question is about apparatus used in the laboratory.

(a) Complete the table by giving the name of each piece of apparatus and a unit used for the quantity it measures.

(2)

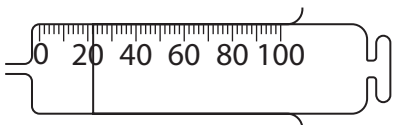
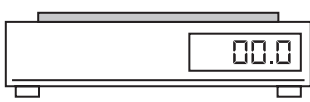
Apparatus	Name	Unit
		
		

(b) The diagram shows apparatus used to obtain pure water from sodium chloride solution by simple distillation.

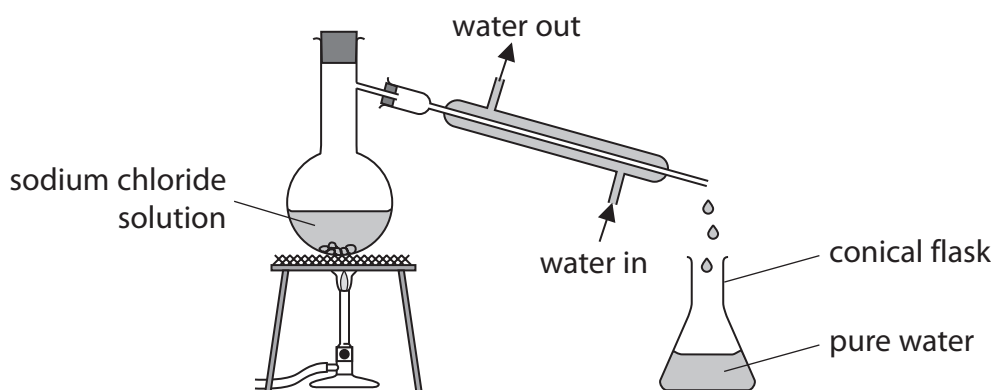

(i) Explain why it is necessary for water to flow continuously in and out of the apparatus.

(2)

.....

.....

.....

.....



(ii) Describe a chemical test to show that the sodium chloride solution contains chloride ions.

(2)

(iii) Describe a physical test to show that the liquid in the conical flask is pure water.

(2)

(Total for Question 2 = 8 marks)

DO NOT WRITE IN THIS AREA

DO NOT WRITE IN THIS AREA

DO NOT WRITE IN THIS AREA



3 The diagram shows a chromatogram of the food dyes in four different food colourings, A, B, C and D.

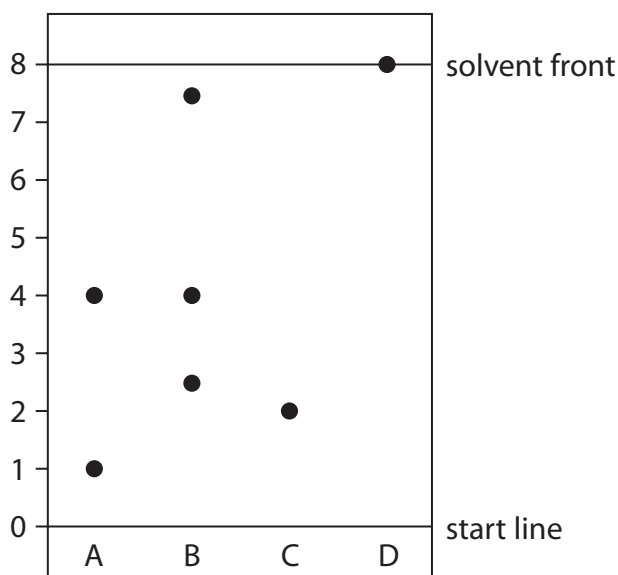

DO NOT WRITE IN THIS AREA

DO NOT WRITE IN THIS AREA

DO NOT WRITE IN THIS AREA

(a) (i) Give the letter of the food colouring that contains three different food dyes. (1)

(ii) Give the letters of the two food colourings that contain the same dye. (1)

(iii) Using the scale on the diagram, determine the R_f value of the dye in food colouring C. (2)

R_f =

(iv) Give a reason why the dye in food colouring D moves the furthest from the start line. (1)



(b) Describe how a student could obtain a chromatogram similar to the one shown in the diagram.

(4)

.....

.....

.....

.....

.....

.....

.....

.....

.....

.....

.....

.....

.....

.....

.....

.....

.....

.....

.....

.....

.....

.....

.....

(Total for Question 3 = 9 marks)

DO NOT WRITE IN THIS AREA

DO NOT WRITE IN THIS AREA

DO NOT WRITE IN THIS AREA



4 The diagram shows the positions of some elements in part of the Periodic Table.

Na												Al			S	Cl		
K																		Xe
												In						

(a) (i) Give the symbol of a metal from the diagram.

(1)

(ii) Give the symbol of an element from the diagram that forms an acidic oxide.

(1)

(b) Give a similarity in the electron configurations of Al and In.

(1)

(c) Explain which element in the diagram is unreactive.

(2)

DO NOT WRITE IN THIS AREA

DO NOT WRITE IN THIS AREA

DO NOT WRITE IN THIS AREA



- (d) A teacher adds a small piece of sodium to a glass trough containing water and universal indicator.

The universal indicator changes colour.

The equation for the reaction is

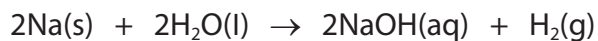

- (i) Explain the final colour of the universal indicator.

(2)

.....

.....

.....

.....

- (ii) The teacher repeats the experiment with potassium instead of sodium.

Give one similarity and one difference observed with potassium.

(2)

similarity

.....

.....

difference

.....

.....

DO NOT WRITE IN THIS AREA

DO NOT WRITE IN THIS AREA

DO NOT WRITE IN THIS AREA



(iii) The reaction with sodium produces 0.036 g of hydrogen gas.

One mole of hydrogen gas contains 6.0×10^{23} molecules.

Calculate the number of molecules of hydrogen gas produced in the reaction with sodium.

Give your answer to two significant figures.

(3)

number of molecules of hydrogen gas =

(Total for Question 4 = 12 marks)

DO NOT WRITE IN THIS AREA

DO NOT WRITE IN THIS AREA

DO NOT WRITE IN THIS AREA



5 This question is about metal carbonates.

When heated, some metal carbonates decompose to form a metal oxide and carbon dioxide gas.

- (a) A student is given three solid metal carbonates, a timer, some limewater and this apparatus.

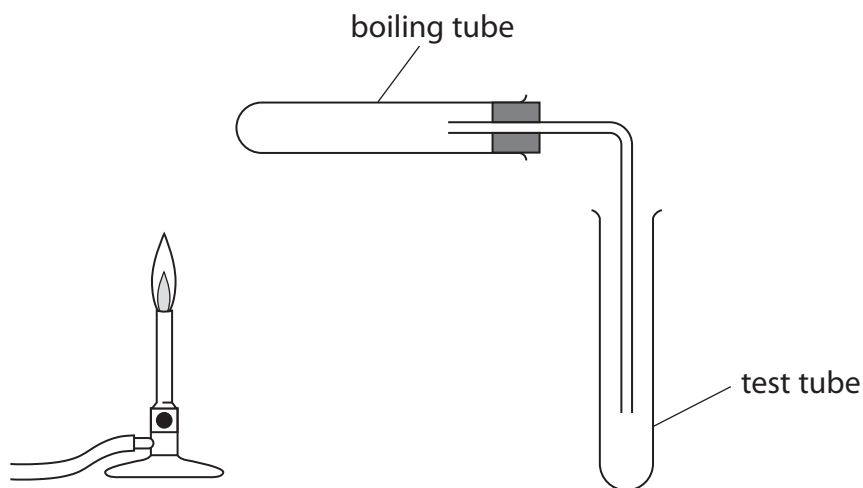

Describe a method the student can use to find out which metal carbonate decomposes fastest when heated.

(4)

.....

.....

.....

.....

.....

.....

.....

.....

.....

.....

.....

.....

.....

.....

.....

.....

.....

.....

.....

.....

.....

.....

.....



P 7 0 9 4 6 A 0 1 3 3 6

(b) A student is given a solid metal carbonate with the formula XCO_3

X represents the symbol of a Group 2 metal.

A student uses this apparatus to heat a sample of XCO_3 until it all decomposes.

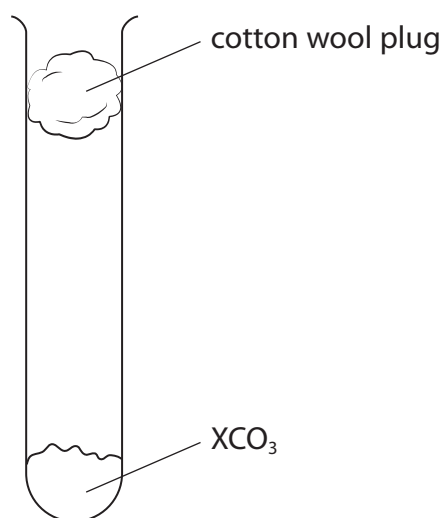

The equation for the decomposition of XCO_3 is



The student records the mass of XCO_3 and the mass of carbon dioxide that escapes through the cotton wool plug.

These are the student's results.

mass of $\text{XCO}_3 = 7.40 \text{ g}$

mass of $\text{CO}_2 = 2.20 \text{ g}$

(i) Give a reason why the student uses a cotton wool plug.

(1)



(ii) Calculate the amount, in mol, of carbon dioxide produced.

[for carbon dioxide $M_r = 44$]

(1)

amount of carbon dioxide = mol

(iii) Use the equation to determine the amount, in mol, of XCO_3 that decomposed.

(1)

amount of $XCO_3 = \dots\dots\dots$ mol

(iv) Use the mass of XCO_3 and your answer to (b)(iii) to calculate the relative formula mass (M_r) of XCO_3

(2)

M_r of $XCO_3 = \dots\dots\dots$

(v) Use your answer to (b)(iv) and the Periodic Table on page 2 to determine the identity of the Group 2 metal X.

Show your working.

(2)

identity of X =
 identity of X =

(Total for Question 5 = 11 marks)

DO NOT WRITE IN THIS AREA

DO NOT WRITE IN THIS AREA

DO NOT WRITE IN THIS AREA



P 7 0 9 4 6 A 0 1 5 3 6

6 Silicon hydride (SiH_4) and silicon dioxide (SiO_2) both contain covalent bonds but they have different structures.

(a) Describe the forces of attraction in a covalent bond.

(2)

.....

.....

.....

.....

(b) Complete the diagram to show the outer shell electrons in a molecule of silicon hydride (SiH_4).

(1)

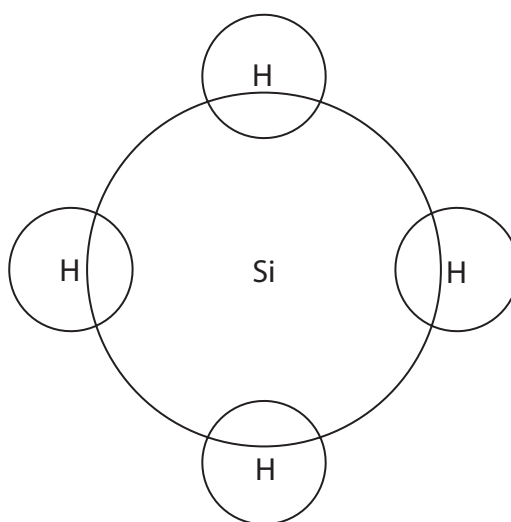

(c) The diagram represents part of the structure of silicon dioxide (SiO_2).

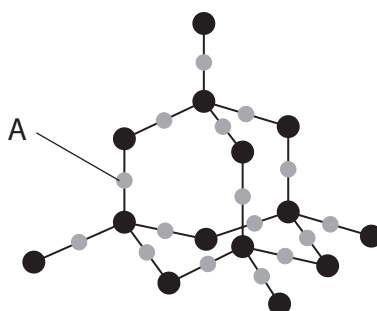

(i) State how the diagram shows that the atom labelled A is oxygen, not silicon.

(1)

.....

.....

DO NOT WRITE IN THIS AREA

DO NOT WRITE IN THIS AREA

DO NOT WRITE IN THIS AREA



7 The diagram shows some important conversion processes used in the oil industry.

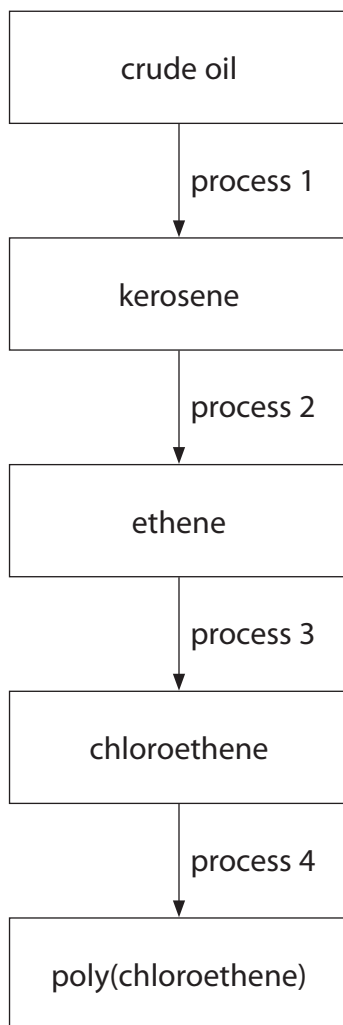

DO NOT WRITE IN THIS AREA

DO NOT WRITE IN THIS AREA

DO NOT WRITE IN THIS AREA



(a) Describe how kerosene is produced from crude oil in process 1.

(5)

DO NOT WRITE IN THIS AREA

DO NOT WRITE IN THIS AREA

DO NOT WRITE IN THIS AREA

Area with horizontal dotted lines for writing the answer.



(b) $C_{12}H_{26}$ is present in kerosene.

In process 2, $C_{12}H_{26}$ is cracked to produce two molecules of ethene and one molecule of another hydrocarbon.

(i) Complete the equation for the cracking of $C_{12}H_{26}$

(1)

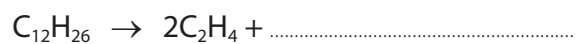

(ii) Explain why cracking is a useful process in the oil industry.

(4)

.....

.....

.....

.....

.....

.....

.....

.....

.....

(c) This is the equation for one of the reactions that may occur during process 3.

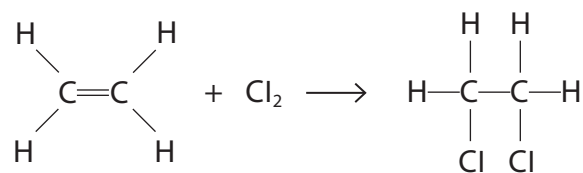

What is the name of this type of reaction?

(1)

- A addition
- B combustion
- C decomposition
- D substitution



(d) (i) Complete the equation for the polymerisation of chloroethene in process 4.

(2)

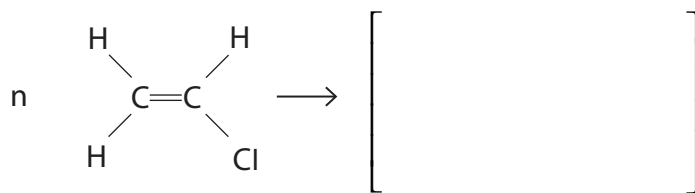

(ii) Explain why the disposal of polymers such as poly(chloroethene) is difficult.

(2)

.....

.....

.....

.....

.....

.....

(Total for Question 7 = 15 marks)

DO NOT WRITE IN THIS AREA

DO NOT WRITE IN THIS AREA

DO NOT WRITE IN THIS AREA



8 This question is about exothermic reactions.

- (a) A student uses this apparatus to measure the temperature increase when an excess of zinc powder is added to copper(II) sulfate solution.

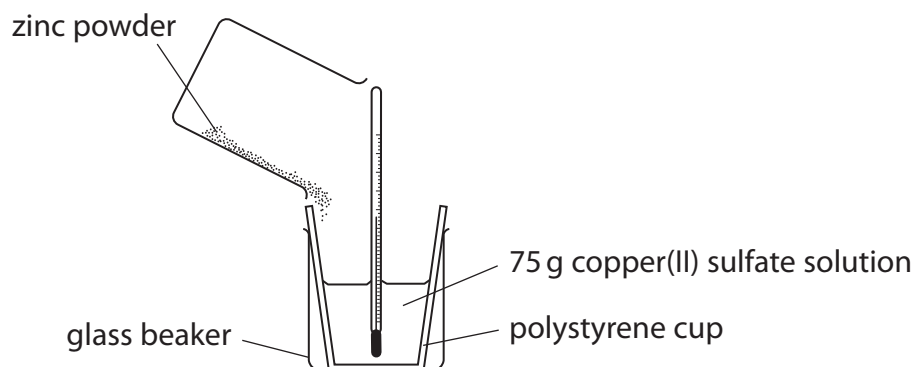

- (i) Complete the word equation for the reaction.

(1)

zinc + copper(II) sulfate → +

- (ii) Give a reason why the student uses a polystyrene cup inside a glass beaker.

(1)

.....

.....

- (iii) State why zinc reacts with copper(II) sulfate solution.

(1)

.....

.....

DO NOT WRITE IN THIS AREA

DO NOT WRITE IN THIS AREA

DO NOT WRITE IN THIS AREA



(iv) The temperature at the start of the reaction is 19.7°C .

The temperature at the end of the reaction is 48.3°C .

Calculate the heat energy change, in joules, for the reaction.

[for the mixture, $c = 4.2\text{J/g}^{\circ}\text{C}$]

(2)

heat energy change = J

(b) (i) The reaction between zinc and silver nitrate solution is exothermic.

A mass of 0.65g of zinc is added to excess silver nitrate solution.

The heat energy change is 800J .

Calculate the molar enthalpy change, ΔH , in kJ/mol .

Include a sign in your answer.

(3)

$\Delta H = \dots\dots\dots\text{kJ/mol}$

DO NOT WRITE IN THIS AREA

DO NOT WRITE IN THIS AREA

DO NOT WRITE IN THIS AREA



P 7 0 9 4 6 A 0 2 3 3 6

- (ii) This is the ionic equation for the reaction between zinc and silver nitrate solution.

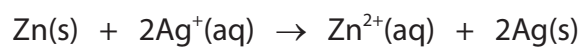

Explain, in terms of electrons, why this is a redox reaction.

(2)

.....

.....

.....

.....

.....

.....

.....

(Total for Question 8 = 10 marks)

DO NOT WRITE IN THIS AREA

DO NOT WRITE IN THIS AREA

DO NOT WRITE IN THIS AREA



DO NOT WRITE IN THIS AREA

DO NOT WRITE IN THIS AREA

DO NOT WRITE IN THIS AREA

BLANK PAGE



9 This question is about rates of reaction.

(a) A student uses this method to investigate the rate of reaction between iron(III) nitrate solution and sodium thiosulfate solution.

- pour 50 cm^3 of iron(III) nitrate solution into a conical flask
- add one drop of catalyst solution
- add 50 cm^3 of sodium thiosulfate solution to the conical flask
- record the time for the mixture to become colourless

The student repeats the method using different catalysts and also with no catalyst.

The table shows the student's results.

Catalyst	Time for mixture to become colourless in s
no catalyst	55
cobalt(II) chloride solution	32
copper(II) sulfate solution	8
iron(II) sulfate solution	27
zinc nitrate solution	75

(i) Explain which is the best catalyst for the reaction.

(2)

.....

.....

.....

.....

(ii) Explain how a catalyst increases the rate of a reaction.

(2)

.....

.....

.....

.....

DO NOT WRITE IN THIS AREA

DO NOT WRITE IN THIS AREA

DO NOT WRITE IN THIS AREA



(b) The rate of a reaction can also be altered by changing the temperature or by changing the concentration of solutions.

- (i) Explain, using the particle collision theory, how increasing the temperature affects the rate of a reaction.

(4)

.....

.....

.....

.....

.....

.....

.....

.....

.....

.....

.....

.....

.....

.....

.....

.....

.....

.....

.....

.....

.....

.....

.....

- (ii) Explain why using a solution of a lower concentration decreases the rate of reaction.

(2)

.....

.....

.....

.....

.....

.....

.....

.....

.....

.....

.....

.....

.....

.....

.....

.....

.....

.....

.....

.....

.....

.....

(Total for Question 9 = 10 marks)

DO NOT WRITE IN THIS AREA

DO NOT WRITE IN THIS AREA

DO NOT WRITE IN THIS AREA



P 7 0 9 4 6 A 0 2 7 3 6

- 10 A student investigates how the electrical conductivity changes as dilute sulfuric acid is added to barium hydroxide solution.

This is the student's method.

- Step 1** add 50.0 cm^3 of barium hydroxide solution to a beaker
- Step 2** measure the electrical conductivity of the solution
- Step 3** add 10.0 cm^3 of dilute sulfuric acid to the beaker
- Step 4** stir the mixture
- Step 5** measure the electrical conductivity of the mixture
- Step 6** repeat steps 3 to 5 until a total of 100 cm^3 of dilute sulfuric acid has been added

The table shows the student's results.

Total volume of acid added in cm^3	Electrical conductivity in arbitrary units
0.0	10.0
10.0	8.0
20.0	7.2
30.0	4.0
40.0	2.0
50.0	0.0
60.0	1.4
70.0	2.8
80.0	4.2
90.0	5.6
100.0	7.0

DO NOT WRITE IN THIS AREA

DO NOT WRITE IN THIS AREA

DO NOT WRITE IN THIS AREA



- (a) (i) Name a piece of apparatus the student could use to add 10.0 cm^3 of dilute sulfuric acid to the beaker. (1)

- (ii) Plot the student's results. (2)

- (iii) Ignoring the anomalous result, draw two lines of best fit, making sure that the two lines cross. (1)

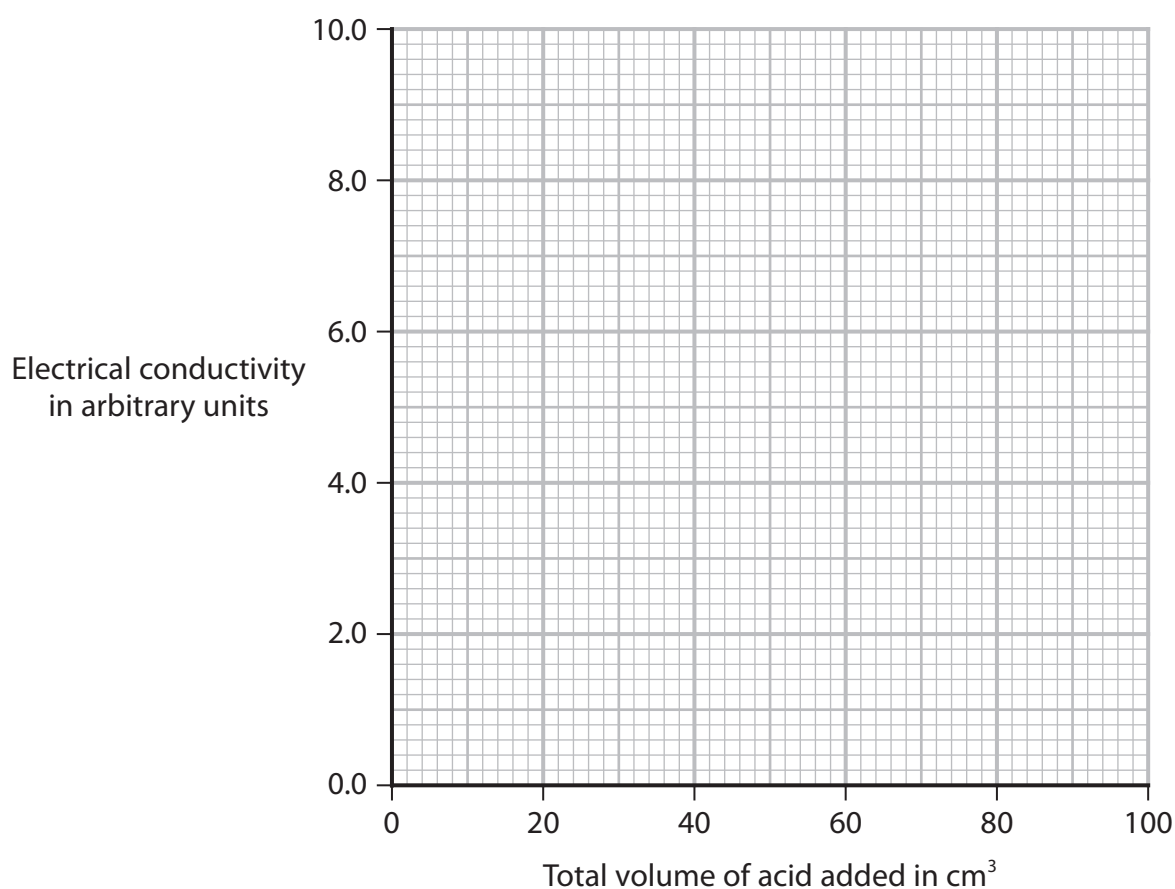

- (iv) Give the trend shown on the graph for the first 50 cm^3 of acid added. (1)

- (v) Suggest a mistake the student could have made to cause the anomalous result. (1)



P 7 0 9 4 6 A 0 2 9 3 6

(b) This is the equation for the reaction.

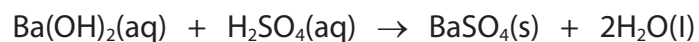

- (i) When 50 cm^3 of dilute sulfuric acid have been added, only barium sulfate and water are present in the mixture.

Explain why this mixture does not conduct electricity.

Refer to the type of bonding in barium sulfate and in water in your answer.

(3)

.....

.....

.....

.....

.....

.....

.....

.....

.....

.....

- (ii) Name a technique the student could use to separate barium sulfate from the mixture after 100 cm^3 of dilute sulfuric acid has been added.

(1)

.....

(Total for Question 10 = 10 marks)



DO NOT WRITE IN THIS AREA

DO NOT WRITE IN THIS AREA

DO NOT WRITE IN THIS AREA

BLANK PAGE



11 This question is about the reduction of tungsten oxide, WO_3

(a) A teacher uses this apparatus to reduce tungsten oxide.

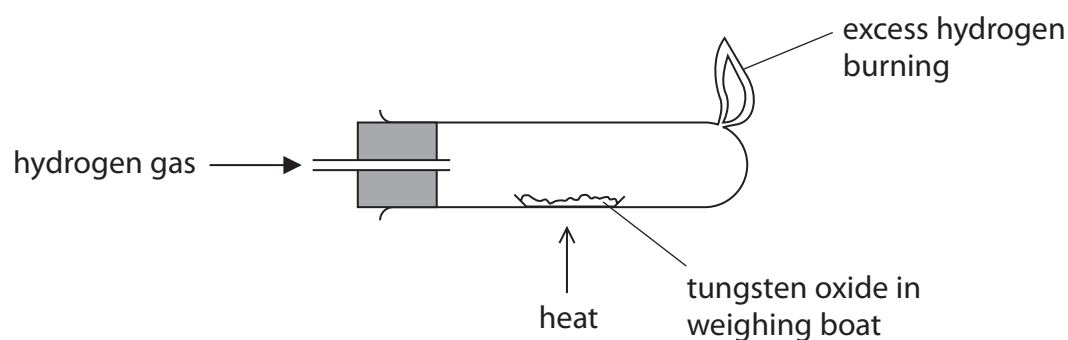

This is the teacher's method.

- record the mass of a weighing boat
- add tungsten oxide and record the mass again
- heat the weighing boat and tungsten oxide strongly for two minutes and then allow to cool
- record the mass of the weighing boat and its contents

(i) Complete the equation by adding the state symbols.

(2)

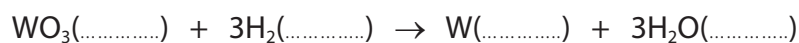

(ii) Give an addition to the method to check that the tungsten oxide has been completely reduced.

(1)

.....

.....



(iii) The table shows the teacher's results.

	Mass in g
empty weighing boat	14.72
weighing boat and tungsten oxide	17.04
weighing boat and tungsten	16.56

Use the teacher's results to show that the empirical formula of tungsten oxide is WO_3

[for tungsten, $A_r = 184$ for oxygen, $A_r = 16$]

(3)

(iv) The teacher wears eye protection and a lab coat during the experiment.

Give one other safety precaution the teacher should take.

(1)



(b) In industry, tungsten oxide is reduced on a large scale using hydrogen.

The percentage yield of tungsten is 73.5%

This is the equation for the reaction.

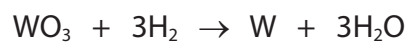

Calculate the mass, in tonnes, of tungsten that is produced when 2784 tonnes of tungsten oxide are reacted with an excess of hydrogen.

[1 tonne = 1×10^6 g]

[for tungsten, $A_r = 184$ for oxygen, $A_r = 16$]

(3)

mass of tungsten = tonnes

(Total for Question 11 = 10 marks)

TOTAL FOR PAPER = 110 MARKS



DO NOT WRITE IN THIS AREA

DO NOT WRITE IN THIS AREA

DO NOT WRITE IN THIS AREA

BLANK PAGE



DO NOT WRITE IN THIS AREA

DO NOT WRITE IN THIS AREA

DO NOT WRITE IN THIS AREA

BLANK PAGE

