



# Cambridge IGCSE™

---

## BIOLOGY

0610/23

Paper 2 Multiple Choice (Extended)

May/June 2020

45 minutes

You must answer on the multiple choice answer sheet.

You will need: Multiple choice answer sheet  
Soft clean eraser  
Soft pencil (type B or HB is recommended)

---

## INSTRUCTIONS

- There are **forty** questions on this paper. Answer **all** questions.
- For each question there are four possible answers **A, B, C** and **D**. Choose the **one** you consider correct and record your choice in soft pencil on the multiple choice answer sheet.
- Follow the instructions on the multiple choice answer sheet.
- Write in soft pencil.
- Write your name, centre number and candidate number on the multiple choice answer sheet in the spaces provided unless this has been done for you.
- Do **not** use correction fluid.
- Do **not** write on any bar codes.
- You may use a calculator.

## INFORMATION

- The total mark for this paper is 40.
- Each correct answer will score one mark. A mark will not be deducted for a wrong answer.
- Any rough working should be done on this question paper.

---

This document has **16** pages. Blank pages are indicated.



## 2

- 1 The diagram shows what happened in an experiment with plant seedlings.

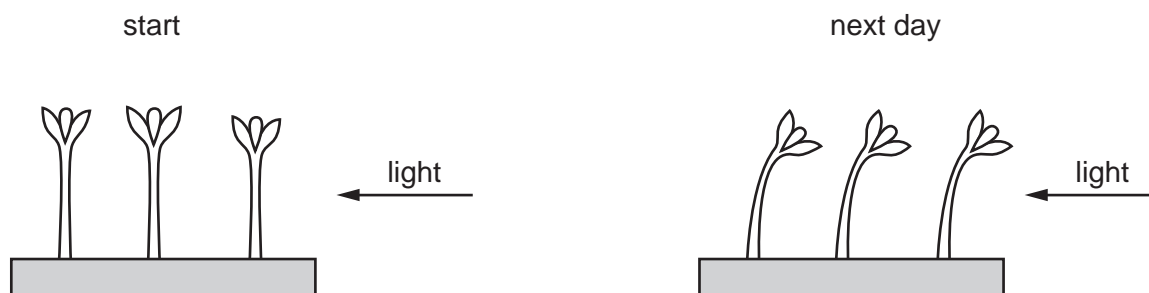

Which characteristic of living things made the seedlings grow towards the light?

- A excretion
  - B nutrition
  - C respiration
  - D sensitivity
- 2 A rat has the scientific name *Rattus rattus*.

What do the two parts of this name refer to?

- A genus and species
  - B kingdom and genus
  - C kingdom and species
  - D variety and genus
- 3 Onion plant cells swell but do not burst when placed in distilled water.

Which cell component prevents the onion plant cells from bursting?

- A cell membrane
- B cell wall
- C nucleus
- D vacuole

3

- 4 The diagram shows an onion plant epidermal cell.

The distance between X and Y on the diagram is 60 mm.

The actual length of the cell between X and Y was 150  $\mu\text{m}$ .

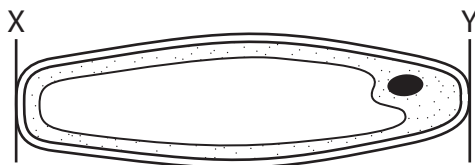

What is the magnification of the cell?

- A  $\times 40$                       B  $\times 250$                       C  $\times 400$                       D  $\times 2500$
- 5 Which diagram shows the appearance of a plant cell several minutes after it has been placed in a concentrated solution of sugar?

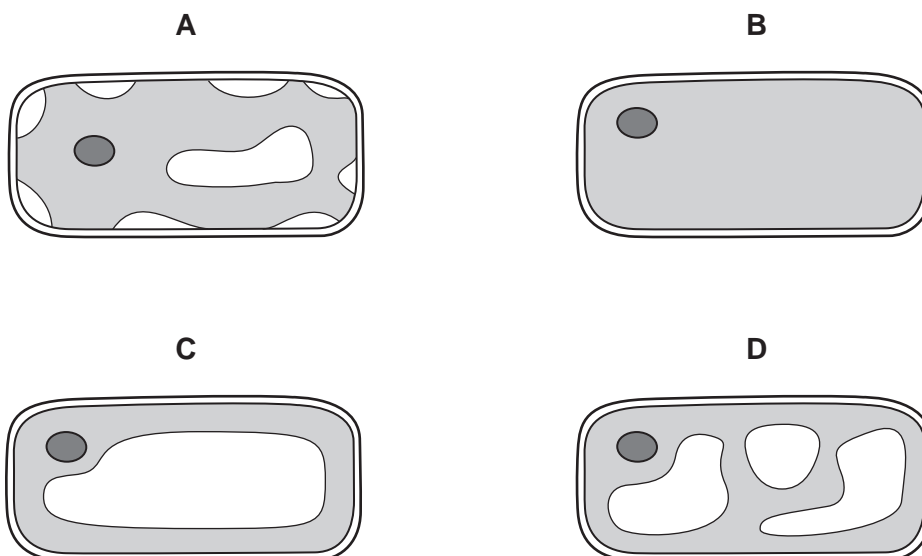

4

- 6 The diagram shows two adjacent plant cells.

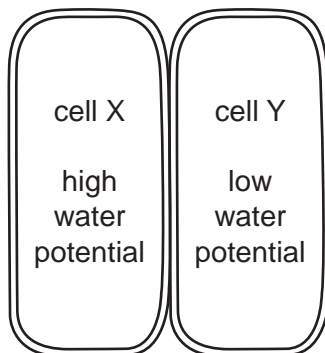

Which statement describes what will happen to the water in the cells?

- A equal movement between cells
  - B net movement from X to Y
  - C net movement from Y to X
  - D no movement between cells
- 7 The diagram shows a section of DNA, with four bases identified on one strand.

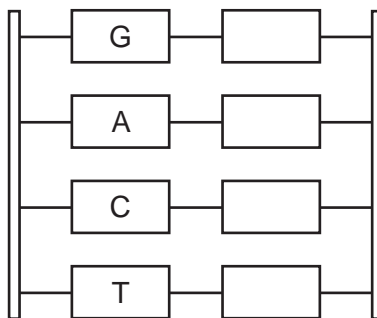

Which sequence of bases would be on the other strand, starting from the top?

- A AGTC
  - B CTGA
  - C GACT
  - D TCAG
- 8 Which food-testing solution shows a positive result when it turns from blue to purple?
- A Benedict's solution
  - B biuret solution
  - C ethanol
  - D iodine solution

- 9 Which statement about enzyme-controlled reactions is correct?
- A During the reaction, a substrate changes into a product.
- B The enzyme is slowly broken down during the reaction.
- C The higher the pH the faster the reaction.
- D The product is gradually used up during the reaction.
- 10 Increasing temperature above the optimum for the enzyme results in loss of enzyme activity.

How is this explained?

- A less frequent collisions between the enzyme and the substrate
- B reduced kinetic energy of the enzyme molecule
- C substrate molecules move faster and effective collisions are less likely
- D the shape of the active site is changed and the substrate will no longer fit into it
- 11 The diagram shows how the rate of photosynthesis varies with light intensity.

The four curves show different conditions of temperature and carbon dioxide concentration.

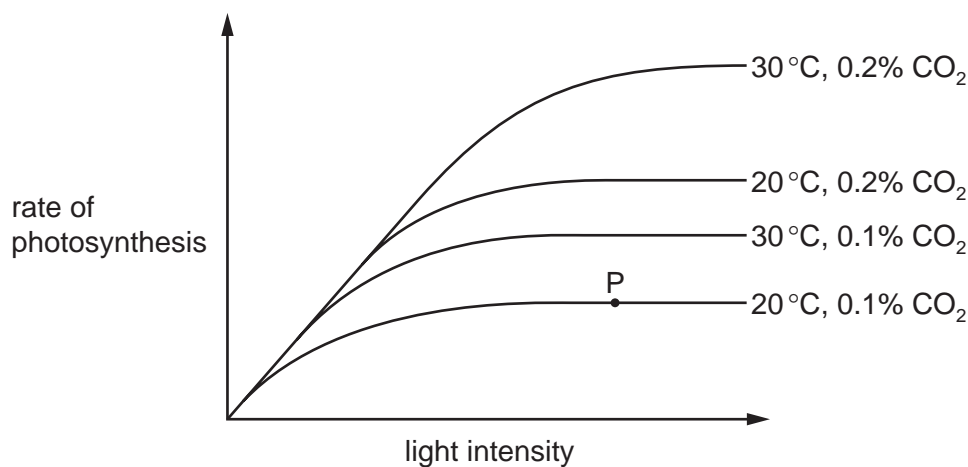

What limits the rate of photosynthesis at point P?

	light intensity	carbon dioxide concentration	temperature
<b>A</b>	✓	✓	✗
<b>B</b>	✓	✗	✗
<b>C</b>	✗	✓	✓
<b>D</b>	✗	✗	✓

key

✓ = yes

✗ = no

12 Why do plants need nitrate ions?

- A to make amino acids
- B to make fats
- C to make glucose
- D to make starch

13 The table shows the percentage of the daily recommended intake of nutrients in a serving of four foods.

Which food would be the best choice to prevent scurvy?

	percentage of daily recommended intake in a serving of food			
	calcium	iron	vitamin C	vitamin D
<b>A</b>	71	1	0	6
<b>B</b>	24	11	2	73
<b>C</b>	3	3	72	0
<b>D</b>	1	72	1	0

14 The diagram shows a villus in the small intestine.

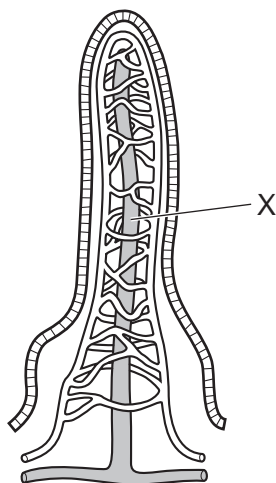

What is absorbed at X?

- A fats
- B glucose
- C glycogen
- D starch

- 15 Samphire is a plant that grows in coastal areas. It has adaptations that enable it to live in areas with high salt concentration in the soil and strong winds.

Which adaptations would samphire possess to minimise water loss from root cells by osmosis and leaves by evaporation?

	salt concentration in root cells	leaf surface area
<b>A</b>	high	high
<b>B</b>	high	low
<b>C</b>	low	high
<b>D</b>	low	low

- 16 Which row correctly states the pair of conditions that will result in the highest rate of transpiration?

	temperature	humidity
<b>A</b>	high	low
<b>B</b>	high	high
<b>C</b>	low	high
<b>D</b>	low	low

- 17 The diagram shows some veins in the human arm and the valves that they contain.

If blood is squeezed out of section X–Y, where should pressure be placed on a vein to stop blood flowing into this section again?

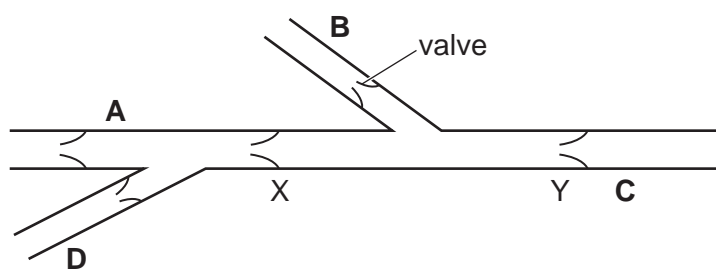

18 The diagram shows some of the blood vessels leaving and returning to the heart.

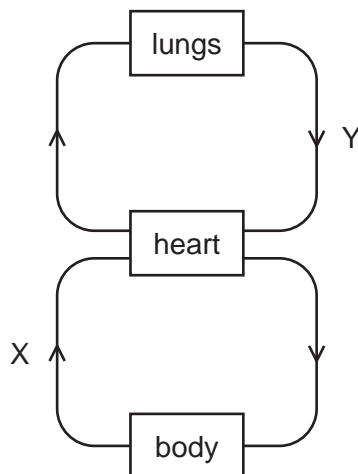

Which row is correct for blood vessels X and Y?

	name of blood vessel X	description of oxygen content of the blood in X	name of blood vessel Y	description of oxygen content of the blood in Y
<b>A</b>	aorta	deoxygenated	pulmonary artery	oxygenated
<b>B</b>	aorta	oxygenated	pulmonary vein	deoxygenated
<b>C</b>	vena cava	deoxygenated	pulmonary vein	oxygenated
<b>D</b>	vena cava	oxygenated	pulmonary artery	deoxygenated

19 Vaccinations can be given to gain active immunity.

Which statement about this type of vaccination is correct?

- A** The vaccination contains antibodies.
- B** The vaccination must contain harmful pathogens.
- C** The vaccination triggers antibody production in the body.
- D** The vaccination triggers antigen production in the body.



20 The diagram shows an alveolus and capillary in a human lung.

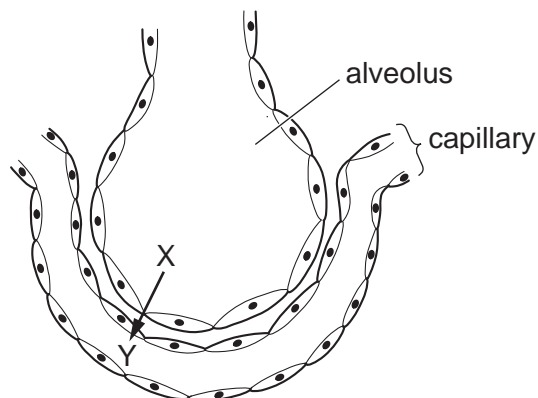

Which row shows the correct gas and concentrations for diffusion from X to Y in normal conditions?

	at point X	at point Y
<b>A</b>	high concentration of carbon dioxide	low concentration of carbon dioxide
<b>B</b>	high concentration of oxygen	low concentration of oxygen
<b>C</b>	low concentration of carbon dioxide	high concentration of carbon dioxide
<b>D</b>	low concentration of oxygen	high concentration of oxygen

21 The symbol equation for aerobic respiration is shown.

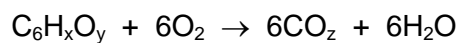

Which numbers represent the letters shown in the equation as x, y and z?

	x	y	z
<b>A</b>	2	12	6
<b>B</b>	6	2	12
<b>C</b>	6	12	2
<b>D</b>	12	6	2

- 22 Blood glucose level is kept between 5–7 mmol per dm<sup>3</sup>. The concentration of glucose in the intestine varies and is often less than that value.

What would be required for the absorption of glucose into the blood when the concentration of glucose in the intestine is less than 5 mmol per dm<sup>3</sup>?

- 1 mitochondria
- 2 oxygen
- 3 membrane proteins

**A** 1 only      **B** 1 and 2 only      **C** 2 and 3 only      **D** 1, 2 and 3

- 23 The diagram shows a synapse between a motor neurone and a relay neurone.

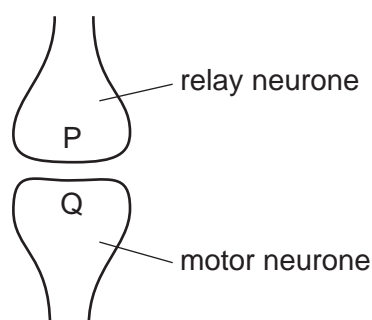

What passes from P to Q?

- A** an electrical impulse
- B** an enzyme
- C** a hormone
- D** a neurotransmitter

- 24 What change occurs in a 'fight or flight' situation?

- A** constriction of pupils
- B** decrease in breathing rate
- C** decrease in pulse rate
- D** increase in blood glucose concentration

- 25 What happens when a person enters a very hot room?

- A** Sweating decreases and vasoconstriction increases.
- B** Sweating decreases and vasodilation decreases.
- C** Sweating increases and vasoconstriction increases.
- D** Sweating increases and vasodilation increases.

26 Which disease is caused by a virus?

- A AIDS
- B kwashiorkor
- C cholera
- D MRSA infection

27 Which row describes cross-pollination?

	pollen transferred from anther to stigma of		
	a different flower on same plant	a flower on a different plant of same species	a flower on a different plant of a different species
A	✓	✓	✗
B	✓	✗	✓
C	✗	✓	✗
D	✗	✗	✓

28 The diagram shows the head of a sperm.

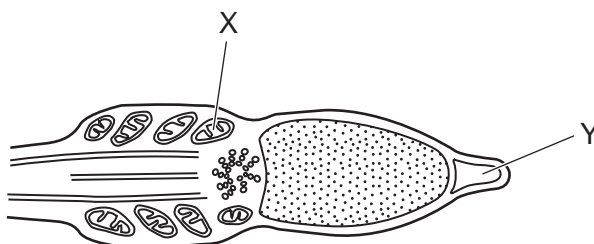

What are the functions of structures X and Y?

	X	Y
A	protein synthesis	digestion of egg cell jelly coat
B	releases energy for movement	digestion of egg cell jelly coat
C	protein synthesis	energy store
D	releases energy for movement	energy store

29 Which row describes what happens in the production of proteins?

	what forms the genetic code	what the DNA codes for	what carries a copy of the gene to the cytoplasm
<b>A</b>	sequence of amino acids	sequence of bases	mRNA
<b>B</b>	sequence of amino acids	sequence of proteins	ribosomes
<b>C</b>	sequence of bases	sequence of amino acids	mRNA
<b>D</b>	sequence of bases	sequence of proteins	ribosomes

30 Which statement about meiosis is correct?

- A** Meiosis produces diploid cells.
- B** Meiosis produces genetically identical cells.
- C** Meiosis produces gametes.
- D** Meiosis produces cells for growth of tissues.

31 The diagram shows the inheritance of ABO blood groups. The blood groups of some of the individuals are given.

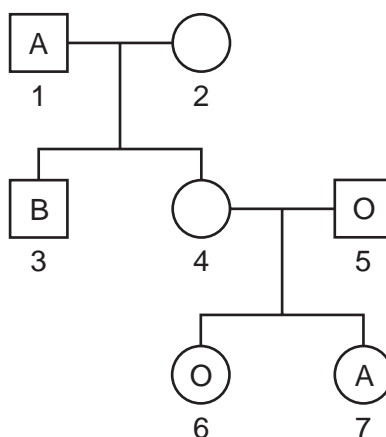

What could be person 2's genotype?

- A**  $I^A I^O$
- B**  $I^B I^B$
- C**  $I^B I^O$
- D**  $I^O I^O$

32 In mice, the allele for black hair is dominant to the allele for brown hair.

What proportion of offspring will have brown hair if a cross is made between a homozygous black mouse and a heterozygous black mouse?

- A** 0%
- B** 25%
- C** 50%
- D** 100%

33 The graph shows the masses of two different types of tomato.

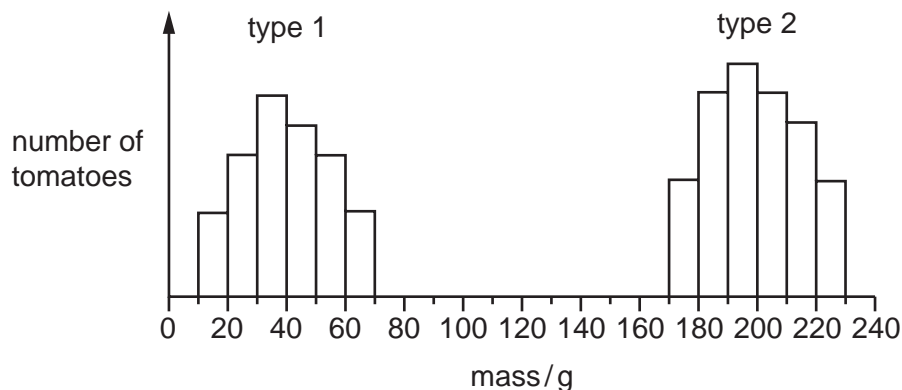

What can be concluded from the graph?

- A Genes do not affect the mass of tomatoes.
  - B Type 1 tomatoes show continuous variation.
  - C Type 2 tomatoes are sometimes smaller than type 1 tomatoes.
  - D Type 2 tomatoes show discontinuous variation.
- 34 Which adaptation may be present in a xerophyte?
- A leaves with small surface area and large numbers of stomata
  - B little or no xylem tissue and leaves with large surface area
  - C stomatal hairs and rolled leaves
  - D thin or no cuticle and deep roots
- 35 The diagram shows a food chain in a rock pool.

seaweed → whelks → crabs → seagulls

What will happen if the number of secondary consumers increases?

There will be

- A fewer crabs.
- B fewer seagulls.
- C fewer whelks.
- D less seaweed.

36 What is defined as 'all of the populations of different species in an ecosystem'?

- A community
- B environment
- C habitat
- D trophic level

37 What is the role of anaerobic respiration in bread-making?

- A to produce alcohol to flavour the bread
- B to produce gas to make the bread rise
- C to release enough energy to bake the bread
- D to release enough lactic acid to kill the yeast

38 A crop plant has been genetically modified to make it resistant to herbicides.

Which is a possible disadvantage of introducing this new crop plant?

- A Loss of weeds reduces competition.
- B Some weeds might become resistant to the herbicide.
- C The crop plant is unharmed and produces a higher yield.
- D The new gene will appear in new generations of the crop.

39 Chickens are birds that are farmed to produce eggs for human consumption.

A type of chicken has been bred to lay **more** eggs.

Which method would be used to produce this type of chicken?

- A asexual reproduction
- B biotechnology
- C natural selection
- D selective breeding

40 When a river is polluted by fertiliser, the following processes may occur.

- 1 increased aerobic respiration of decomposers
- 2 increased growth of producers
- 3 decreased oxygen concentration in the water

What is the correct sequence for these processes?

- A 1 → 2 → 3
- B 1 → 3 → 2
- C 2 → 1 → 3
- D 2 → 3 → 1

**BLANK PAGE**

**BLANK PAGE**

---

Permission to reproduce items where third-party owned material protected by copyright is included has been sought and cleared where possible. Every reasonable effort has been made by the publisher (UCLES) to trace copyright holders, but if any items requiring clearance have unwittingly been included, the publisher will be pleased to make amends at the earliest possible opportunity.

To avoid the issue of disclosure of answer-related information to candidates, all copyright acknowledgements are reproduced online in the Cambridge Assessment International Education Copyright Acknowledgements Booklet. This is produced for each series of examinations and is freely available to download at [www.cambridgeinternational.org](http://www.cambridgeinternational.org) after the live examination series.

Cambridge Assessment International Education is part of the Cambridge Assessment Group. Cambridge Assessment is the brand name of the University of Cambridge Local Examinations Syndicate (UCLES), which itself is a department of the University of Cambridge.