

Please check the examination details below before entering your candidate information

Candidate surname				Other names			
Pearson Edexcel		Centre Number			Candidate Number		
International GCSE (9–1)		<input type="text"/>	<input type="text"/>	<input type="text"/>	<input type="text"/>	<input type="text"/>	<input type="text"/>
Tuesday 14 May 2019							
Afternoon (Time: 2 hours)				Paper Reference 4BI1/1B 4SD0/1B			
Biology Unit: 4BI1 Science (Double Award) 4SD0 Paper: 1B							
You must have: Calculator, ruler						Total Marks	

Instructions

- Use **black** ink or ball-point pen.
- **Fill in the boxes** at the top of this page with your name, centre number and candidate number.
- Answer **all** questions.
- Answer the questions in the spaces provided
– *there may be more space than you need.*
- Show all the steps in any calculations and state the units.
- Some questions must be answered with a cross in a box . If you change your mind about an answer, put a line through the box and then mark your new answer with a cross .

Information

- The total mark for this paper is 110.
- The marks for **each** question are shown in brackets
– *use this as a guide as to how much time to spend on each question.*

Advice

- Read each question carefully before you start to answer it.
- Write your answers neatly and in good English.
- Try to answer every question.
- Check your answers if you have time at the end.

Turn over ►

P58564RA

©2019 Pearson Education Ltd.

1/1/1/1/1/



Pearson

Answer ALL questions.

1 This is a three-dimensional diagram of a plant cell.

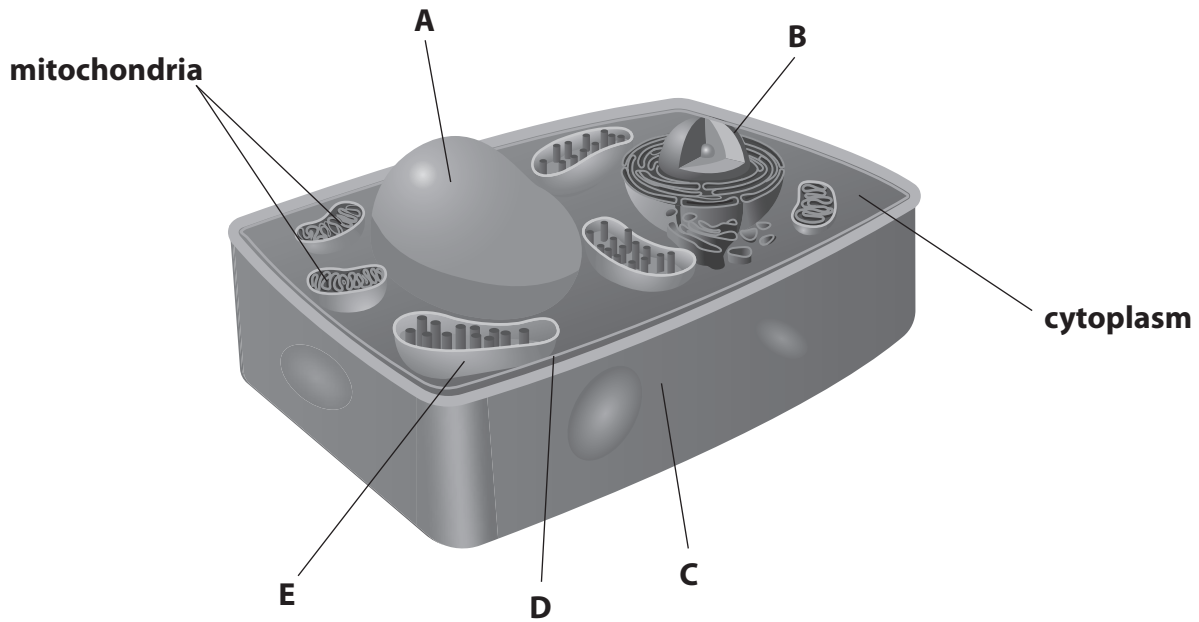

(a) Name the structures labelled A, B, C, and D.

(4)

A

B

C

D

(b) Structure E is a chloroplast.

Chloroplasts are not found in animal cells.

(i) Give the letter of another structure shown in the diagram but not found in animal cells.

(1)

.....

DO NOT WRITE IN THIS AREA

DO NOT WRITE IN THIS AREA

DO NOT WRITE IN THIS AREA

DO NOT WRITE IN THIS AREA

DO NOT WRITE IN THIS AREA

DO NOT WRITE IN THIS AREA





BLANK PAGE

DO NOT WRITE IN THIS AREA

DO NOT WRITE IN THIS AREA

DO NOT WRITE IN THIS AREA

DO NOT WRITE IN THIS AREA

DO NOT WRITE IN THIS AREA

DO NOT WRITE IN THIS AREA



2 The photograph shows a type of fish called a salmon.



(Source: © Alexander Rath/Shutterstock)

Some humans eat salmon as a source of protein.

Protein is a component of a balanced diet.

(a) Which statement describes what happens to salmon protein in the human stomach? (1)

- A it is digested into amino acids
- B its surface area is increased by bile
- C its pH is raised by hydrochloric acid
- D it is absorbed by villi

(b) The table lists other components of a balanced diet and their functions.

Complete the table by giving a function of each component.

The first one has been done for you.

(3)

Component	Function
lipid	store of energy
vitamin D	
iron	
fibre	



P 5 8 5 6 4 R A 0 5 3 2

- (c) A student investigates the effect of genetic modification on the growth of salmon.

The student measures the mass and length of one normal salmon and one genetically modified salmon when both salmon are 18 months old.

The table shows the student's results.

Type of salmon	Mass in g	Length in cm
normal	1250	33
genetically modified	3000	61

- (i) It is recommended that a 15-year-old person needs 50g of protein per day for a balanced diet.

A normal salmon contains 20% protein.

Calculate how many 15-year-olds can have their recommended daily allowance of protein supplied by the 18-month-old normal salmon.

(2)

number =

DO NOT WRITE IN THIS AREA

DO NOT WRITE IN THIS AREA

DO NOT WRITE IN THIS AREA

DO NOT WRITE IN THIS AREA

DO NOT WRITE IN THIS AREA

DO NOT WRITE IN THIS AREA



(ii) The student concludes that his results show that genetically modified (GM) salmon are useful in providing a balanced diet.

Discuss the student's conclusion.

(6)

Dotted lines for writing the answer to question (ii).

(d) The passage describes the role of enzymes involved in the genetic modification of salmon.

Complete the passage by writing a suitable word in each space.

(3)

All salmon contain a length of DNA called a, which controls the production of growth hormone. Another length of DNA, from a different species of fish, is cut out using a enzyme. This DNA is then joined to the salmon DNA using an enzyme called

This causes the salmon to produce growth hormone at all times.

(Total for Question 2 = 15 marks)

Blank space for writing the answer to question (d).

DO NOT WRITE IN THIS AREA

DO NOT WRITE IN THIS AREA

DO NOT WRITE IN THIS AREA

DO NOT WRITE IN THIS AREA

DO NOT WRITE IN THIS AREA

DO NOT WRITE IN THIS AREA



3 The diagram shows a food web.

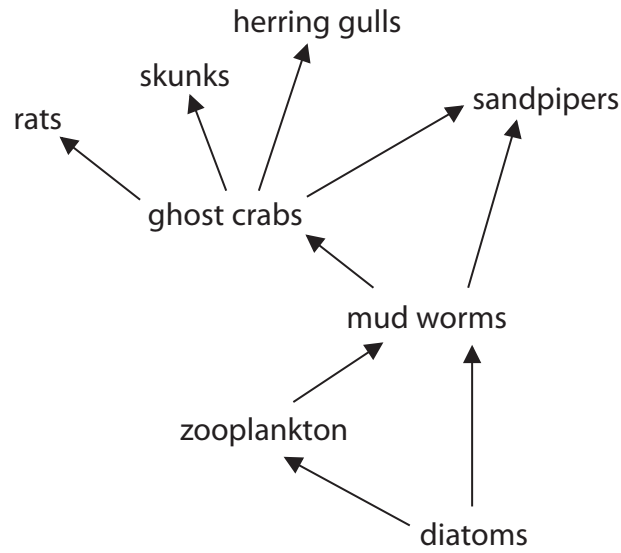

(a) Use information from the food web to complete the table.

The first one has been done for you.

(3)

number of organisms	8
number of producers	
number of primary consumers	
number of food chains	

(b) Explain why the energy in the mud worms is not all transferred to the organisms that eat them.

(4)

.....

.....

.....

.....

.....

.....

.....

.....

DO NOT WRITE IN THIS AREA

DO NOT WRITE IN THIS AREA

DO NOT WRITE IN THIS AREA

DO NOT WRITE IN THIS AREA

DO NOT WRITE IN THIS AREA

DO NOT WRITE IN THIS AREA



4 This apparatus can be used to show osmosis.

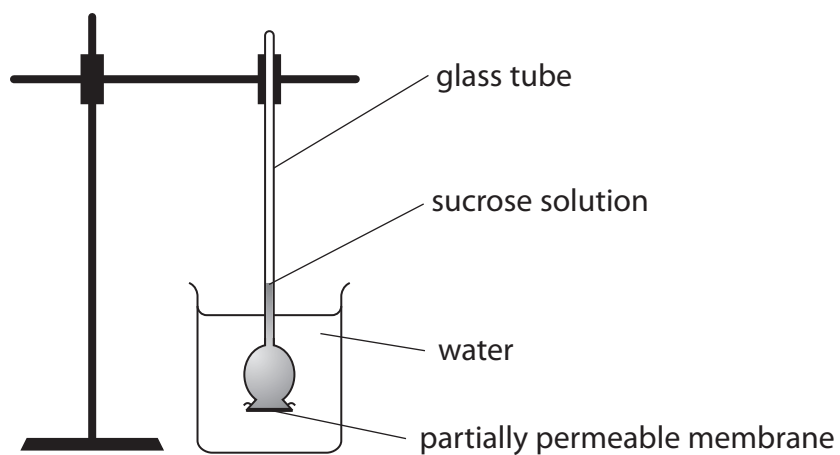

(a) Explain what happens to the level of the sucrose solution in the glass tube.

(3)

.....

.....

.....

.....

.....

.....

(b) Describe how this apparatus could be modified to measure the rate of osmosis at different temperatures.

(3)

.....

.....

.....

.....

.....

.....

.....

.....

.....

.....

(Total for Question 4 = 6 marks)



DO NOT WRITE IN THIS AREA

DO NOT WRITE IN THIS AREA

DO NOT WRITE IN THIS AREA

DO NOT WRITE IN THIS AREA

DO NOT WRITE IN THIS AREA

DO NOT WRITE IN THIS AREA



DO NOT WRITE IN THIS AREA

DO NOT WRITE IN THIS AREA

DO NOT WRITE IN THIS AREA

DO NOT WRITE IN THIS AREA

DO NOT WRITE IN THIS AREA

DO NOT WRITE IN THIS AREA

BLANK PAGE



P 5 8 5 6 4 R A 0 1 1 3 2



5 Wheat seeds contain stores of a large insoluble molecule.

This molecule is digested by amylase as the seeds germinate.

(a) What is the name of this large insoluble molecule?

(1)

- A glucose
- B lipid
- C protein
- D starch

(b) A student investigates the oxygen absorbed by germinating seeds at different temperatures.

The diagram shows some of the student's apparatus.

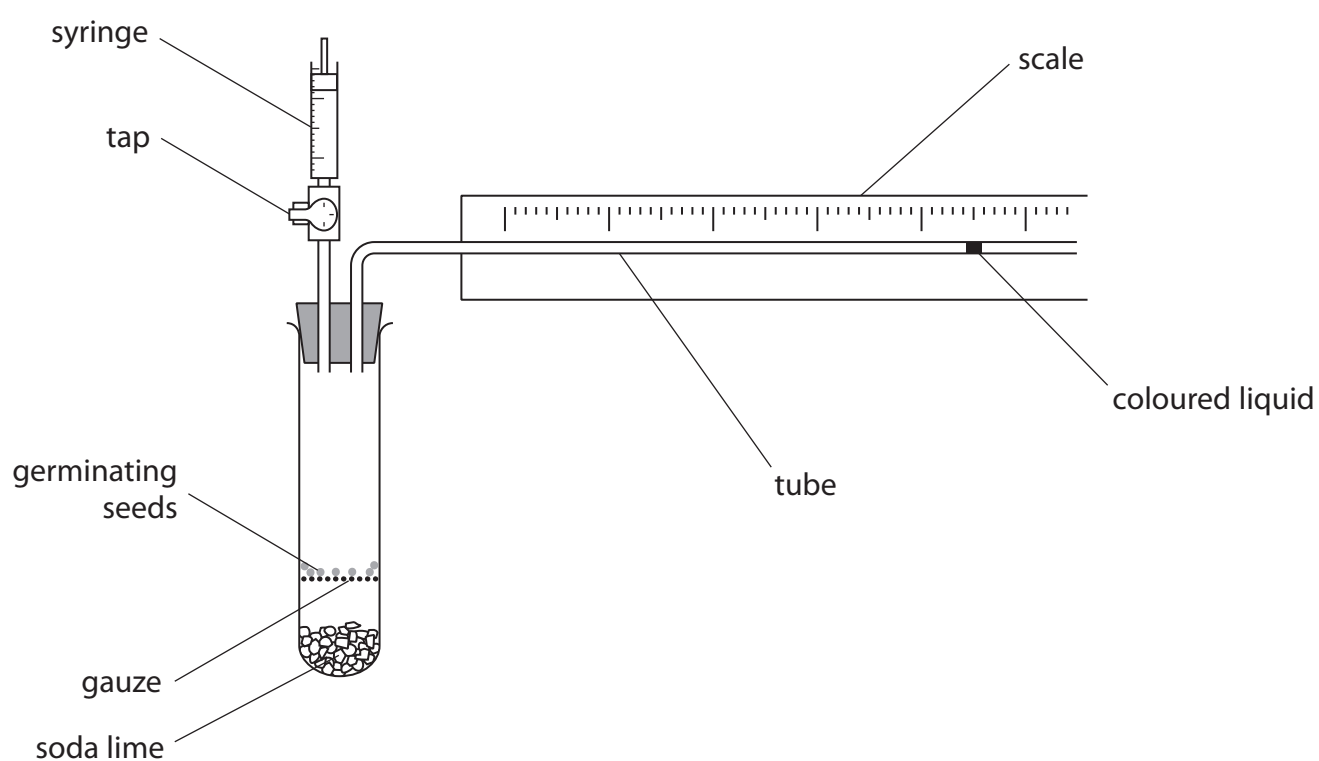

DO NOT WRITE IN THIS AREA

DO NOT WRITE IN THIS AREA

DO NOT WRITE IN THIS AREA

DO NOT WRITE IN THIS AREA

DO NOT WRITE IN THIS AREA

DO NOT WRITE IN THIS AREA



(i) Suggest why the student opens the tap after obtaining one set of results.

(2)

.....

.....

.....

.....

(ii) What is the function of the soda lime?

(1)

- A** it absorbs carbon dioxide
- B** it absorbs oxygen
- C** it releases carbon dioxide
- D** it releases oxygen

(iii) The student measures the distance moved by the coloured liquid and converts this to volume of oxygen absorbed.

The volume of oxygen absorbed can be calculated using the formula

$$\text{volume} = \pi \times \text{radius}^2 \times \text{distance}$$

Calculate the volume of oxygen absorbed when the coloured liquid moves a distance of 6.0 mm.

[diameter of tube = 1.0 mm]

(3)

volume = cm³



P 5 8 5 6 4 R A 0 1 3 3 2

(c) The graph shows the results of the student's investigation.

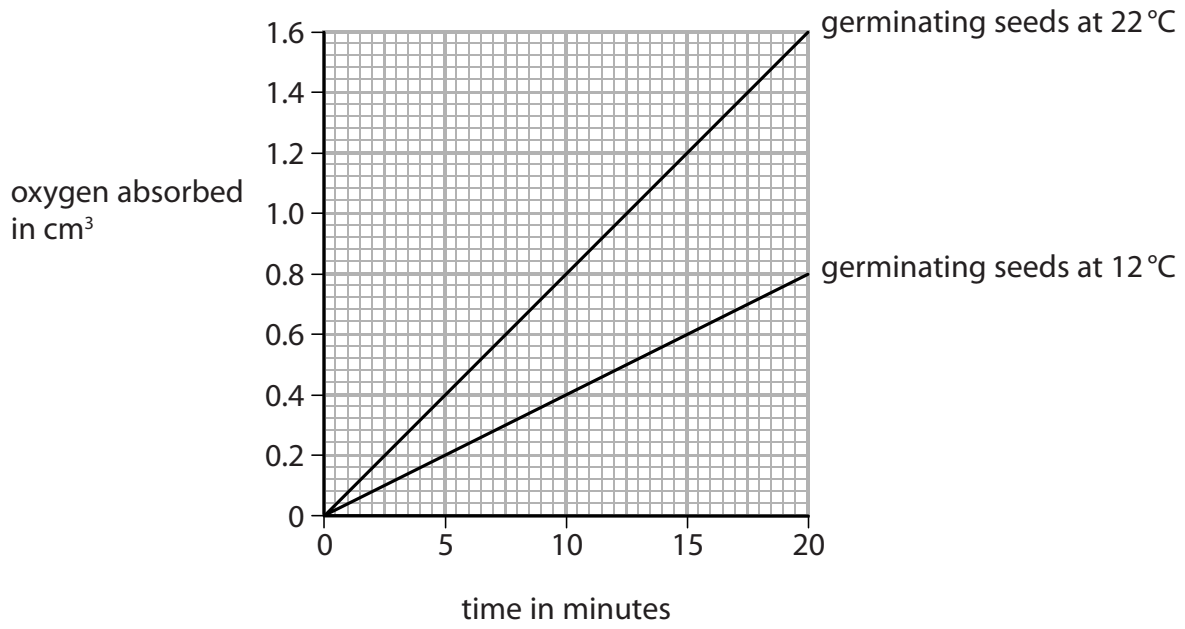

(i) Calculate the percentage increase in the rate of oxygen absorption at 22°C compared to the rate of oxygen absorption at 12°C.

(2)

percentage =

(ii) Suggest why the rate of oxygen absorption is greater at 22°C than at 12°C.

(2)

.....

.....

.....

.....

.....

.....

(Total for Question 5 = 11 marks)



DO NOT WRITE IN THIS AREA

DO NOT WRITE IN THIS AREA

DO NOT WRITE IN THIS AREA

DO NOT WRITE IN THIS AREA

DO NOT WRITE IN THIS AREA

DO NOT WRITE IN THIS AREA

6 The diagram shows a sperm cell from a rat.

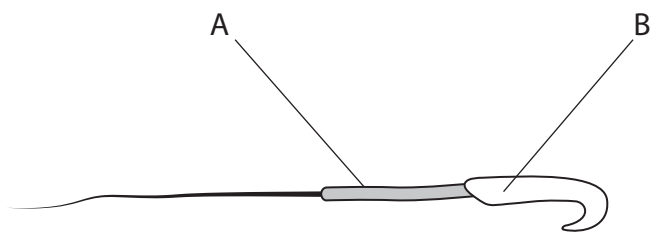

(a) (i) Describe the role of a sperm cell.

(1)

.....

.....

(ii) Describe the structures found in part B.

(2)

.....

.....

.....

(iii) Explain why part A contains many mitochondria.

(2)

.....

.....

.....



P 5 8 5 6 4 R A 0 1 5 3 2

(b) Nicotine is a chemical found in cigarettes.

A scientist investigates how nicotine affects sperm cells.

The scientist gives male rats different concentrations of nicotine.

He then calculates the percentage of damaged sperm cells in the semen produced by each rat.

The table shows his results.

Concentration of nicotine in mg per kg of rat	Percentage of damaged sperm cells (%)
0.0	6.4
0.5	16.8
1.0	24.8

(i) The sample of semen from a rat given a nicotine concentration of 1.0 mg per kg contains 5.8×10^7 sperm cells.

Calculate the number of damaged sperm cells in this sample.

(2)

number =

DO NOT WRITE IN THIS AREA

DO NOT WRITE IN THIS AREA

DO NOT WRITE IN THIS AREA

DO NOT WRITE IN THIS AREA

DO NOT WRITE IN THIS AREA

DO NOT WRITE IN THIS AREA



7 (a) A student investigates the sugar content of four different fruit juices.

This is the student's method.

- add 5 cm³ of fruit juice to a boiling tube
- add 5 cm³ of Benedict's solution to the boiling tube
- place the boiling tube in a water bath at 70 °C for three minutes
- remove the boiling tube and record the colour of the solution

The student uses this method for each of the four fruit juices.

The table shows the student's results.

Fruit juice	Colour of solution after heating for three minutes
A	blue
B	brick red
C	yellow
D	green

(i) Give two variables that the student controls in his investigation.

(2)

1

2

(ii) Give the juices A, B, C and D in order of sugar content, from highest to lowest.

(2)

highest

lowest

DO NOT WRITE IN THIS AREA

DO NOT WRITE IN THIS AREA

DO NOT WRITE IN THIS AREA

DO NOT WRITE IN THIS AREA

DO NOT WRITE IN THIS AREA

DO NOT WRITE IN THIS AREA



(iii) The student is now given sugar solutions with concentrations of 1%, 5%, 10% and 20%.

Explain how the student could use these solutions to estimate the concentration of sugar in the four fruit juices.

(3)

.....

.....

.....

.....

.....

.....

.....

.....

.....

.....

DO NOT WRITE IN THIS AREA

DO NOT WRITE IN THIS AREA

DO NOT WRITE IN THIS AREA

DO NOT WRITE IN THIS AREA

DO NOT WRITE IN THIS AREA

DO NOT WRITE IN THIS AREA





(b) Some fruit juices contain high concentrations of sugar.

These fruit juices increase the number of bacteria in the mouth.

This may lead to an increase in tooth decay.

(i) Suggest why high concentrations of sugar may increase tooth decay.

(2)

.....

.....

.....

.....

.....

.....

(ii) Explain another health risk to children who drink fruit juices with high concentrations of sugars.

(2)

.....

.....

.....

.....

.....

.....

(Total for Question 7 = 11 marks)

DO NOT WRITE IN THIS AREA

DO NOT WRITE IN THIS AREA

DO NOT WRITE IN THIS AREA

DO NOT WRITE IN THIS AREA

DO NOT WRITE IN THIS AREA

DO NOT WRITE IN THIS AREA





DO NOT WRITE IN THIS AREA

DO NOT WRITE IN THIS AREA

DO NOT WRITE IN THIS AREA

DO NOT WRITE IN THIS AREA

DO NOT WRITE IN THIS AREA

DO NOT WRITE IN THIS AREA

BLANK PAGE



P 5 8 5 6 4 R A 0 2 1 3 2



8 A scientist investigates the effect of exercise on breathing rate.

She measures the breathing rate in breaths per minute of two people, P and Q, every 5 minutes for 30 minutes.

This is her method.

- measure their breathing rate every 5 minutes while they exercise for 20 minutes
- measure their breathing rate every 5 minutes for a further 10 minutes while they recover from the exercise

The table shows her results.

Time in minutes	Breathing rate in breaths per minute	
	Person P	Person Q
0	12	15
5	20	24
10	22	24
15	25	23
20	24	20
25	16	19
30	12	15

DO NOT WRITE IN THIS AREA

DO NOT WRITE IN THIS AREA

DO NOT WRITE IN THIS AREA

DO NOT WRITE IN THIS AREA

DO NOT WRITE IN THIS AREA

DO NOT WRITE IN THIS AREA



(a) (i) Plot a line graph of the results for person P and person Q.

Use a ruler to join your points with straight lines.

(6)

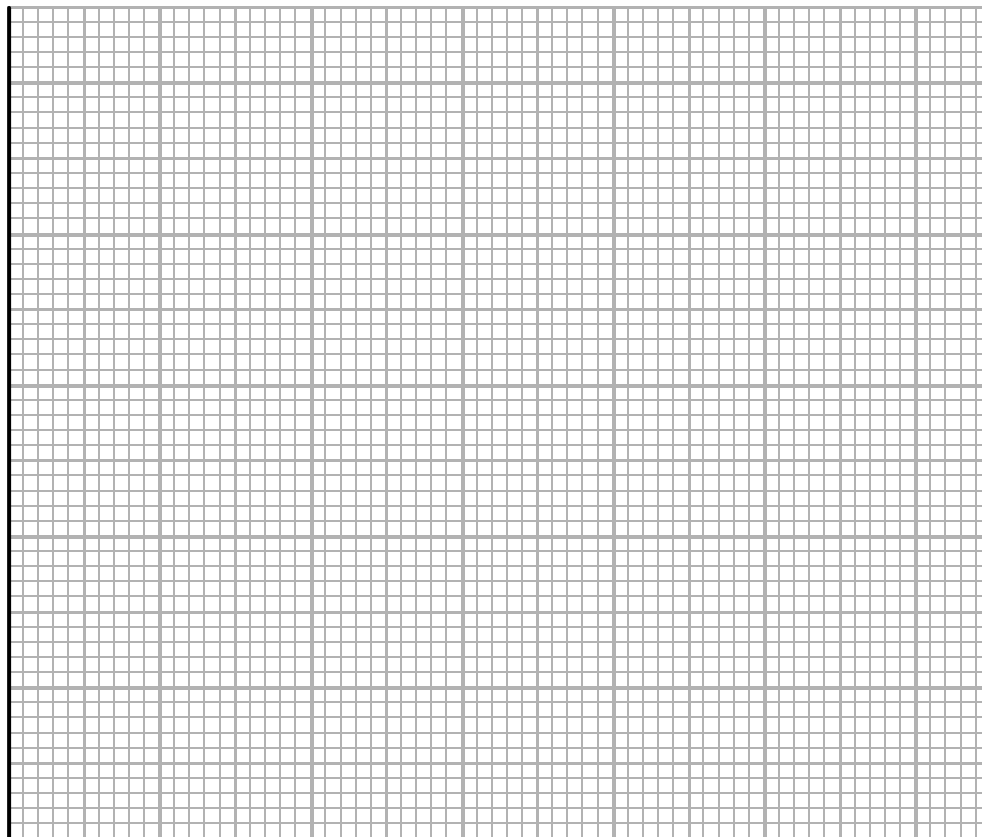

(ii) Explain the change in breathing rate during exercise.

(3)

.....

.....

.....

.....

.....

.....

.....

.....

.....

.....

DO NOT WRITE IN THIS AREA

DO NOT WRITE IN THIS AREA

DO NOT WRITE IN THIS AREA

DO NOT WRITE IN THIS AREA

DO NOT WRITE IN THIS AREA

DO NOT WRITE IN THIS AREA





DO NOT WRITE IN THIS AREA

DO NOT WRITE IN THIS AREA

DO NOT WRITE IN THIS AREA

DO NOT WRITE IN THIS AREA

DO NOT WRITE IN THIS AREA

DO NOT WRITE IN THIS AREA

BLANK PAGE



P 5 8 5 6 4 R A 0 2 5 3 2



9 Pollution can occur in the atmosphere and in rivers.

(a) Carbon monoxide can pollute the atmosphere.

Describe the effects of carbon monoxide pollution on humans.

(3)

.....

.....

.....

.....

.....

.....

DO NOT WRITE IN THIS AREA

DO NOT WRITE IN THIS AREA

DO NOT WRITE IN THIS AREA

DO NOT WRITE IN THIS AREA

DO NOT WRITE IN THIS AREA

DO NOT WRITE IN THIS AREA



(b) Water pollution can occur if sewage enters a river.

Explain the biological consequences of sewage pollution on a river ecosystem.

(6)

Area with horizontal dotted lines for writing the answer.

(Total for Question 9 = 9 marks)

DO NOT WRITE IN THIS AREA

DO NOT WRITE IN THIS AREA

DO NOT WRITE IN THIS AREA

DO NOT WRITE IN THIS AREA

DO NOT WRITE IN THIS AREA

DO NOT WRITE IN THIS AREA



10 (a) Animals produce hormones to communicate between cells.

(i) Which hormone causes the development of secondary sexual characteristics in girls? (1)

- A adrenaline
- B oestrogen
- C progesterone
- D testosterone

(ii) Which hormone causes an increased blood flow to the muscles during exercise? (1)

- A adrenaline
- B insulin
- C progesterone
- D testosterone

(iii) Which of these is a correct statement about hormones? (1)

- A they always produce short-term changes
- B they are carried by neurones
- C they are transported in the plasma
- D they always produce a rapid response

(b) Plants produce plant growth substances such as auxin.

Suggest why some biologists do not consider auxin to be a hormone. (2)

.....

.....

.....

.....

DO NOT WRITE IN THIS AREA

DO NOT WRITE IN THIS AREA

DO NOT WRITE IN THIS AREA

DO NOT WRITE IN THIS AREA

DO NOT WRITE IN THIS AREA

DO NOT WRITE IN THIS AREA





DO NOT WRITE IN THIS AREA

DO NOT WRITE IN THIS AREA

DO NOT WRITE IN THIS AREA

DO NOT WRITE IN THIS AREA

DO NOT WRITE IN THIS AREA

DO NOT WRITE IN THIS AREA

BLANK PAGE



DO NOT WRITE IN THIS AREA

DO NOT WRITE IN THIS AREA

DO NOT WRITE IN THIS AREA

DO NOT WRITE IN THIS AREA

DO NOT WRITE IN THIS AREA

DO NOT WRITE IN THIS AREA

BLANK PAGE



P 5 8 5 6 4 R A 0 3 1 3 2



DO NOT WRITE IN THIS AREA

DO NOT WRITE IN THIS AREA

DO NOT WRITE IN THIS AREA

BLANK PAGE

