



Cambridge International Examinations
Cambridge International General Certificate of Secondary Education

PHYSICS

0625/13

Paper 1 Multiple Choice (Core)

May/June 2016

45 minutes

Additional Materials: Multiple Choice Answer Sheet
Soft clean eraser
Soft pencil (type B or HB recommended)



READ THESE INSTRUCTIONS FIRST

Write in soft pencil.

Do not use staples, paper clips, glue or correction fluid.

Write your name, Centre number and candidate number on the Answer Sheet in the spaces provided unless this has been done for you.

DO NOT WRITE IN ANY BARCODES.

There are **forty** questions on this paper. Answer **all** questions. For each question there are four possible answers **A, B, C** and **D**.

Choose the **one** you consider correct and record your choice in **soft pencil** on the separate Answer Sheet.

Read the instructions on the Answer Sheet very carefully.

Each correct answer will score one mark. A mark will not be deducted for a wrong answer.

Any rough working should be done in this booklet.

Electronic calculators may be used.

Take the weight of 1.0 kg to be 10 N (acceleration of free fall = 10 m/s^2).

The syllabus is approved for use in England, Wales and Northern Ireland as a Cambridge International Level 1/Level 2 Certificate.

This document consists of **17** printed pages and **3** blank pages.

2

- 1 The diagram shows an enlarged drawing of the end of a metre rule. It is being used to measure the length of a small feather.

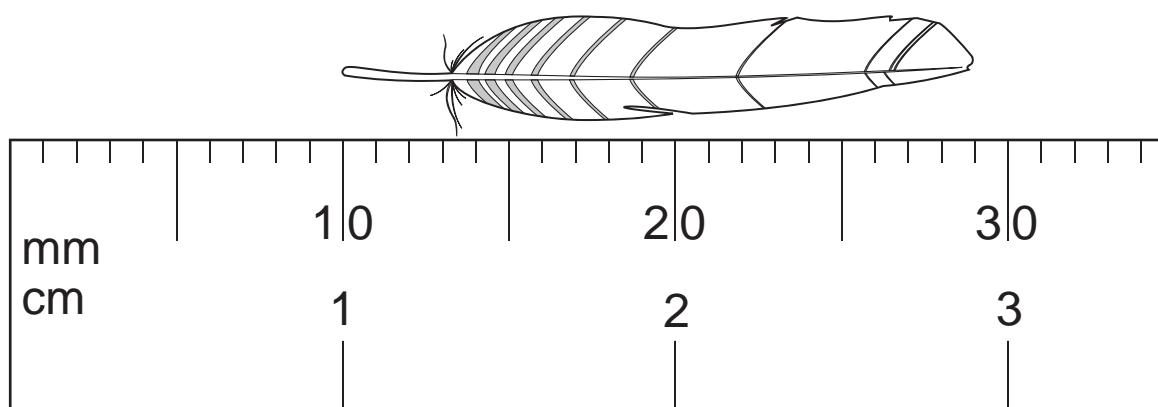

What is the length of the feather?

- A** 19 mm **B** 29 mm **C** 19 cm **D** 29 cm
- 2 An object moves at a constant speed for some time, then begins to accelerate.

Which distance-time graph shows this motion?

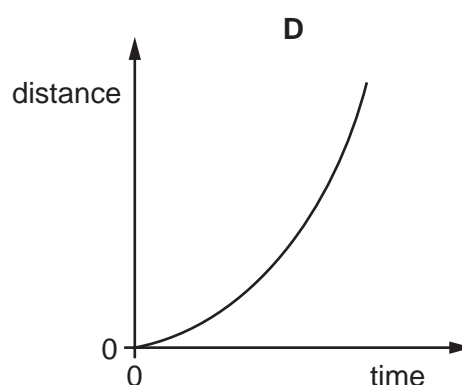
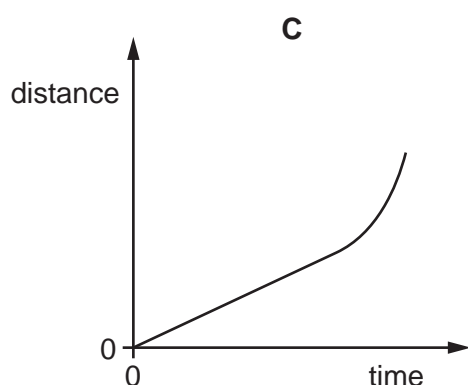
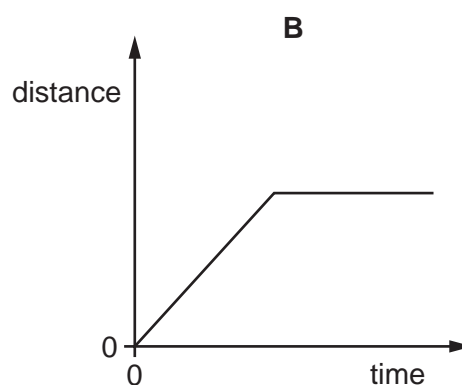
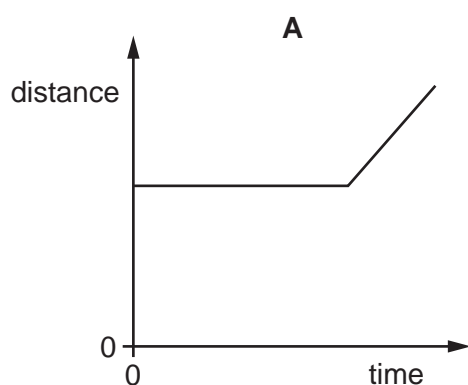

3

- 3 A car travels at an average speed of 60 km/h for 15 minutes.

How far does the car travel in this time?

- A 4.0 km B 15 km C 240 km D 900 km

- 4 A heavy object is released near the surface of the Earth and falls freely. Air resistance can be ignored.

Which statement about the acceleration of the object due to gravity is correct?

- A The acceleration depends on the mass of the object.
B The acceleration depends on the volume of the object.
C The acceleration is constant.
D The acceleration is initially zero and increases as the object falls.

- 5 A cup contains hot liquid.

Some of the liquid evaporates.

What happens to the mass and what happens to the weight of the liquid in the cup?

	mass	weight
A	decreases	decreases
B	decreases	stays the same
C	stays the same	decreases
D	stays the same	stays the same

6 Diagram 1 shows a measuring cylinder containing water.

Diagram 2 shows the same measuring cylinder and water after 10 identical solid glass spheres have been added.

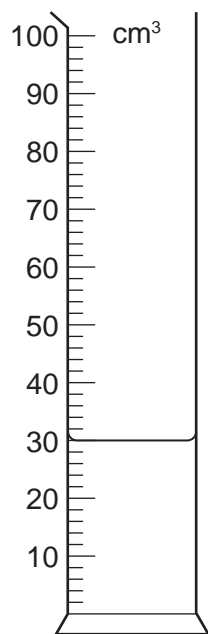

diagram 1

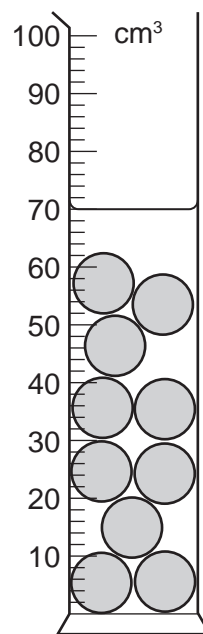

diagram 2

The mass of one of the spheres is 10 g.

What is the density of the glass from which the spheres are made?

- A** 0.25 g/cm^3 **B** 0.40 g/cm^3 **C** 2.5 g/cm^3 **D** 4.0 g/cm^3

7 A feather falls through the air. Its downward speed is constant.

Which statement about the feather is correct?

- A** No energy is lost to the air as the feather falls.
B The air resistance acting on the feather is greater than its weight.
C The feather experiences no resultant vertical force.
D There is a resultant downward force on the feather.

5

- 8 The diagram shows an L-shaped piece of card suspended freely from a pin at **B**.
When the card is pushed, it swings and then comes to a stop in the position shown.
At which labelled point is the centre of mass of the card?

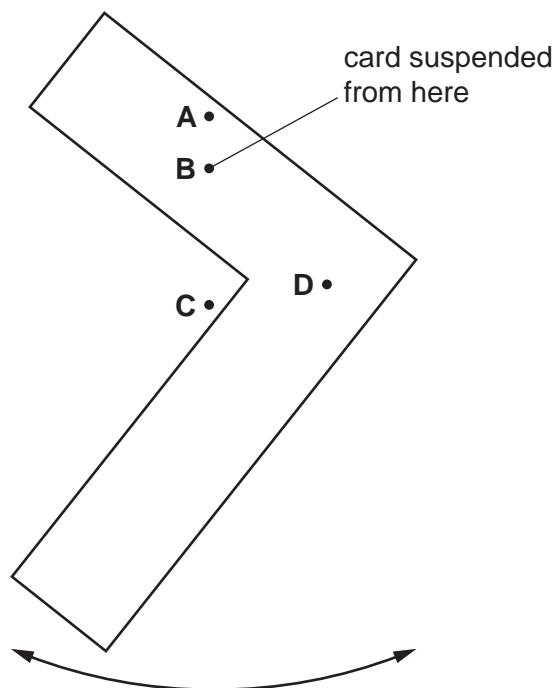

- 9 A skier walks from the bottom of a ski slope to the top and gains 10 000 J of gravitational potential energy.

She skis down the slope. At the bottom of the slope, her kinetic energy is 2000 J.

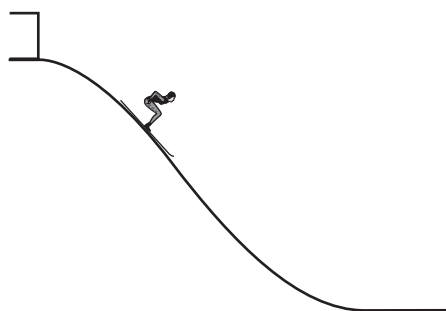

How much energy is dissipated in overcoming friction and air resistance as the skier moves down the slope?

- A** 2000 J **B** 8000 J **C** 10 000 J **D** 12 000 J

10 Which energy source is renewable and reliably available at all times?

- A coal
- B geothermal
- C nuclear
- D wind

11 Two workers are stacking cans on to a shelf in a shop. The workers lift the same number of identical cans on to the same shelf from the same level.

Worker P takes 3.0 minutes to lift the cans. Worker Q takes 4.0 minutes to lift the cans.

Which statement about the workers is correct?

- A Worker P develops less useful power than worker Q.
- B Worker P develops more useful power than worker Q.
- C Worker P does less useful work than worker Q.
- D Worker P does more useful work than worker Q.

12 The diagram shows four solid pieces of the same metal. Each piece has the same thickness and stands on a bench as shown.

Which piece of metal produces the greatest pressure on the bench?

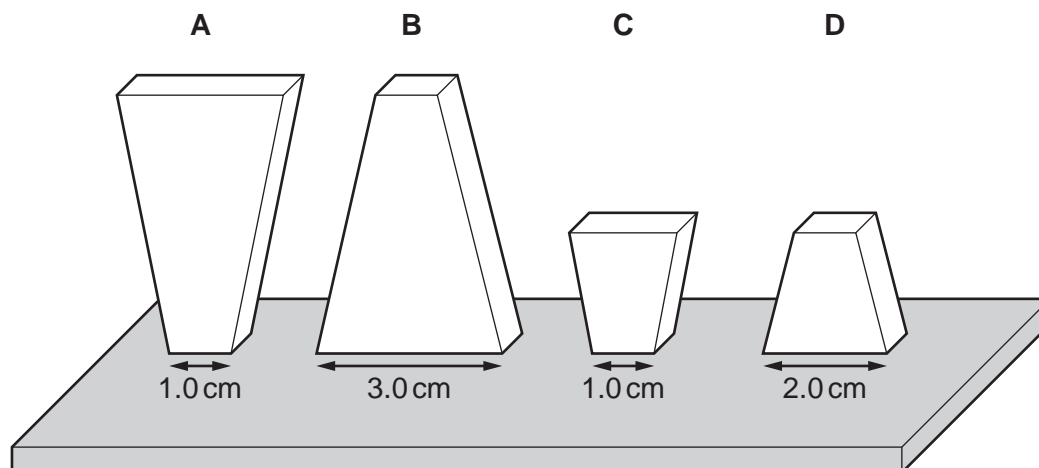

13 The diagram shows a simple mercury barometer.

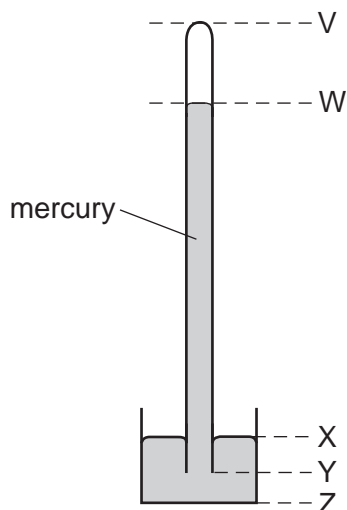

The atmospheric pressure increases.

Which distance increases?

- A** VW **B** WY **C** XY **D** XZ

14 What causes the random, zig-zag movement (Brownian motion) of smoke particles suspended in air?

- A** air molecules colliding with smoke particles
B convection currents as the hot smoke rises
C smoke particles colliding with each other
D smoke particles reacting with oxygen molecules in the air

15 A sealed bottle of constant volume contains air.

The air in the bottle is heated by the Sun.

What is the effect on the average speed of the air molecules in the bottle, and the average distance between them?

	average speed of air molecules	average distance between air molecules
A	decreases	decreases
B	decreases	stays the same
C	increases	increases
D	increases	stays the same

16 The melting points of ethanol and mercury are shown.

	melting point/ $^{\circ}\text{C}$
ethanol	-114
mercury	-39

Which of these two liquids is/are suitable to use in a liquid-in-glass thermometer to measure temperatures of -50°C and -120°C ?

- A ethanol only
- B ethanol and mercury
- C mercury only
- D neither ethanol nor mercury

17 A jug of water is at room temperature.

Several ice cubes at a temperature of 0°C are dropped into the water and they begin to melt immediately.

What happens to the temperature of the water and what happens to the temperature of the ice cubes while they are melting?

	temperature of the water	temperature of the ice cubes
A	decreases	increases
B	decreases	stays constant
C	stays constant	increases
D	stays constant	stays constant

18 Which quantity gives the *thermal capacity* of a beaker?

- A the thermal energy required to change the state of the beaker at constant temperature
- B the thermal energy required to raise the temperature of the beaker by 1°C
- C the total mass of hot liquid that the beaker can hold
- D the total volume of hot liquid that the beaker can hold

- 19 A student suggests some uses for containers made from good thermal conductors and for containers made from poor thermal conductors.

In which row are both suggested uses correct?

	good thermal conductor	poor thermal conductor
A	keeping a cold liquid at a low temperature	transferring thermal energy quickly from a hot liquid
B	keeping a hot liquid at a high temperature	keeping a cold liquid at a low temperature
C	transferring thermal energy quickly from a hot liquid	transferring thermal energy quickly to a cold liquid
D	transferring thermal energy quickly to a cold liquid	keeping a hot liquid at a high temperature

- 20 A rod is made half of glass and half of copper. Four pins **A**, **B**, **C** and **D** are attached to the rod by wax. The rod is heated in the centre as shown.

The pins fall off when the wax melts.

Which pin falls off first?

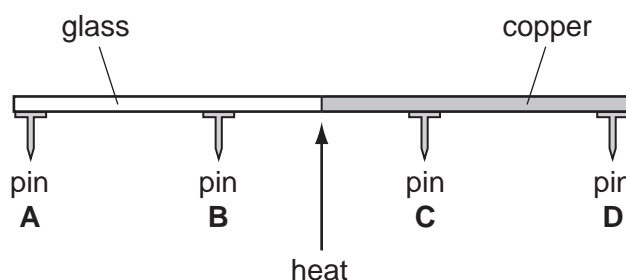

- 21 Which row shows the natures of light waves, sound waves and X-rays?

	light waves	sound waves	X-rays
A	longitudinal	longitudinal	transverse
B	longitudinal	transverse	longitudinal
C	transverse	longitudinal	transverse
D	transverse	transverse	longitudinal

22 Radio waves are received at a house at the bottom of a hill.

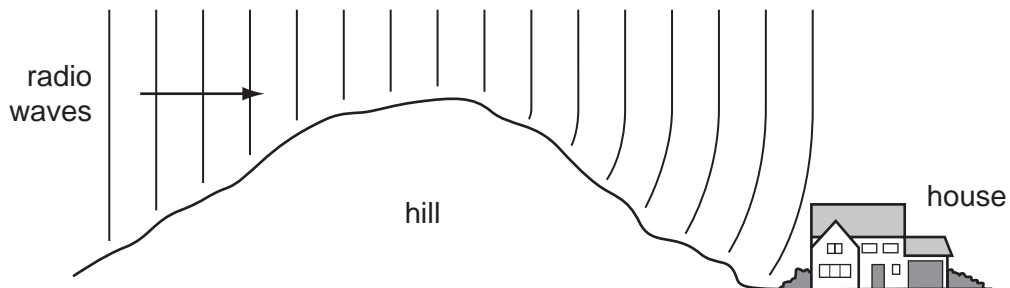

The waves reach the house because the hill has caused them to be

- A diffracted.
- B radiated.
- C reflected.
- D refracted.

23 The diagram shows an object in front of a plane mirror.

At which labelled position is the image of the object formed?

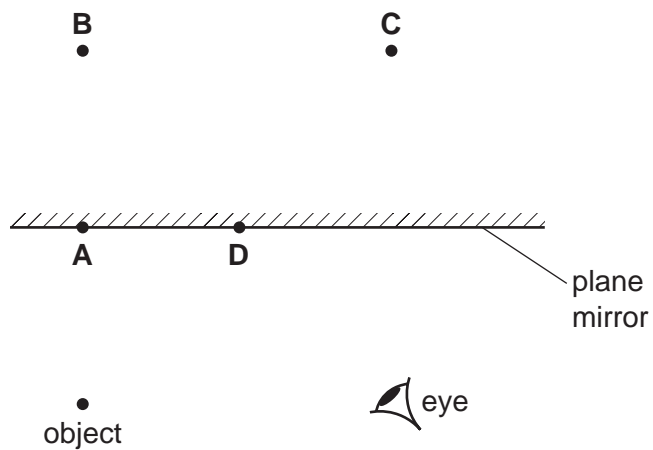

- 24 White light enters a glass prism. The light leaving the other side of the prism is separated into colours.

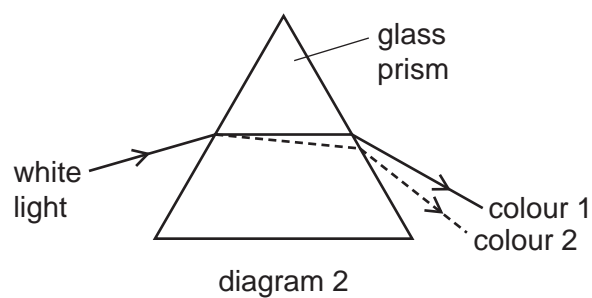
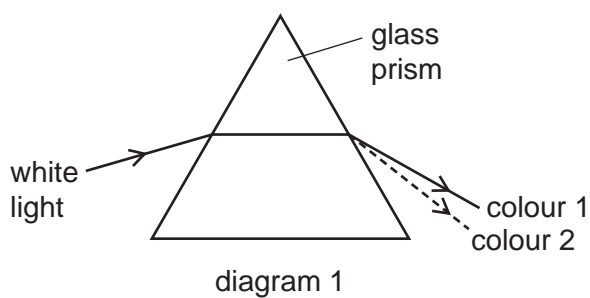

Which row correctly describes what happens?

	path taken by the light	colour 1	colour 2
A	diagram 1	red	violet
B	diagram 1	violet	red
C	diagram 2	red	violet
D	diagram 2	violet	red

- 25 Which range of wave frequencies includes only sounds that can be heard by a human with normal hearing?

- A** 3.0 Hz to 300 Hz
- B** 30 Hz to 3000 Hz
- C** 300 Hz to 30 000 Hz
- D** 3000 Hz to 300 000 Hz

26 A candle flame is placed in front of a loudspeaker.

The loudspeaker produces a sound wave that causes air particles to vibrate. The vibrating air particles make the candle flame vibrate in the same direction as the air particles.

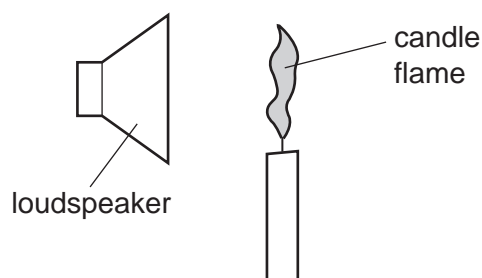

Which row shows the direction of vibration of the candle flame, and the nature of sound waves?

	direction of vibration	nature of sound waves
A	↑ ↓	longitudinal
B	↑ ↓	transverse
C	← →	longitudinal
D	← →	transverse

27 Which statement about magnetism is correct?

- A** An unmagnetised iron bar becomes magnetised when it is placed near a magnet.
- B** An unmagnetised steel bar can be magnetised by passing a current through it.
- C** The direction of magnetic field lines is from an S-pole to an N-pole.
- D** The N-poles of two magnets attract each other.

28 A student wishes to make a permanent magnet. She has an iron rod and a steel rod.

Which rod should she use to make the permanent magnet, and is this rod a hard magnetic material or a soft magnetic material?

	rod	type of magnetic material
A	iron	hard
B	iron	soft
C	steel	hard
D	steel	soft

- 29 A flexible electrical cable consists of a central conductor and outer insulation.

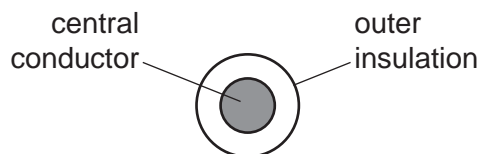

Which pair of materials is suitable for the cable?

	central conductor	outer insulation
A	copper	plastic
B	lead	wood
C	plastic	copper
D	wood	lead

- 30 The diagram shows a battery connected to two resistors.

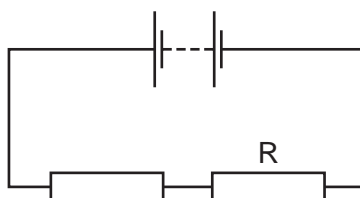

Four students separately measure the electromotive force (e.m.f.) of the battery, the current in the resistors, and the potential difference (p.d.) across resistor R.

Their results are shown in the table below.

Which row shows values with their correct units?

	e.m.f.	current	p.d.
A	3.0 A	0.30 V	1.5 A
B	3.0 A	0.30 A	1.5 V
C	3.0 V	0.30 V	1.5 A
D	3.0 V	0.30 A	1.5 V

- 31 Why are lamps in a house lighting circuit connected in parallel rather than in series?

- A** If one lamp stops working, the remaining lamps become brighter.
- B** Less current is taken from the power supply.
- C** The lamps can be turned off independently using switches.
- D** When more lamps are added, their brightness decreases.

- 32 The diagram shows a cell connected to two 6.0Ω resistors. Three currents, I_1 , I_2 and I_3 , are labelled.

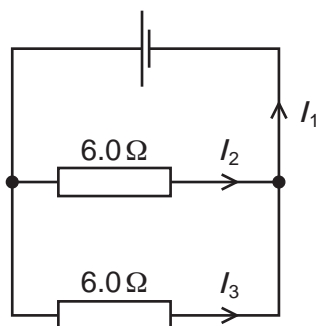

Which row correctly compares I_2 and I_3 with I_1 ?

	I_2	I_3
A	same as I_1	same as I_1
B	same as I_1	smaller than I_1
C	smaller than I_1	same as I_1
D	smaller than I_1	smaller than I_1

- 33 The diagram shows part of a circuit used to switch street lamps on and off automatically.

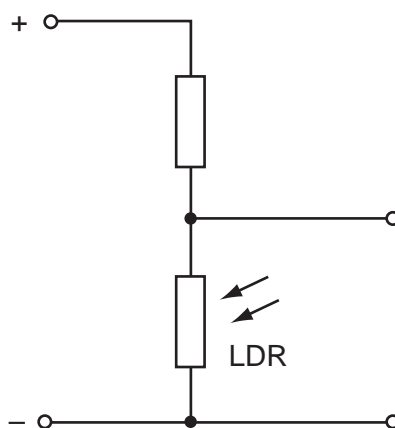

In the evening it gets dark.

Which row shows the effect on the resistance of the light-dependent resistor (LDR) and on the potential difference (p.d.) across it?

	resistance of LDR	p.d. across LDR
A	decreases	decreases
B	decreases	increases
C	increases	decreases
D	increases	increases

- 34** A domestic circuit includes a 30 A fuse. This protects the wiring if there is too much current in the circuit.

In which wire is the 30 A fuse positioned, and what does it do when it operates?

	position	operation
A	live wire	disconnects the circuit
B	live wire	reduces the current to 30 A
C	neutral wire	disconnects the circuit
D	neutral wire	reduces the current to 30 A

- 35** A strong electromagnet is used to attract pins.

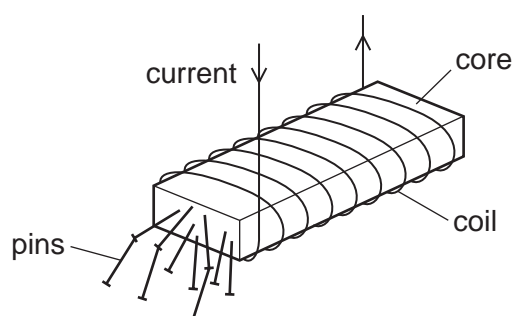

What happens when the current in the coil is halved?

- A** No pins are attracted.
- B** Some pins are attracted, but not as many.
- C** The same number of pins is attracted.
- D** More pins are attracted.

36 The diagram shows a transformer.

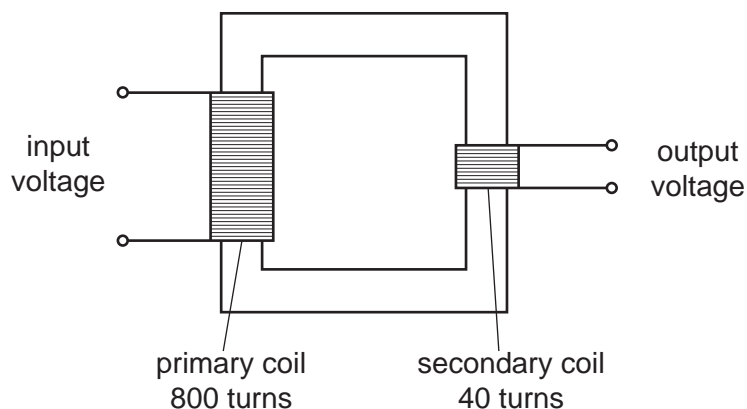

The input voltage is 240 V.

What is the output voltage?

- A** 6.0 V **B** 12 V **C** 20 V **D** 40 V

37 A proton and a neutron are each close to a positive nucleus.



How does the charge on the nucleus affect the proton and the neutron, if at all?

- A** The neutron is attracted; the proton is repelled.
B The neutron is not affected; the proton is repelled.
C The proton is attracted; the neutron is repelled.
D The proton is not affected; the neutron is repelled.

38 Below are four statements about isotopes of a certain element.

Which statement about the isotopes **must** be correct?

- A** They are radioactive.
B They are unstable.
C They have the same number of neutrons.
D They have the same number of protons.

39 Radioactive materials should be handled carefully.

Which safety precaution does **not** reduce the risk to people using a radioactive material?

- A keeping the material a long distance from people
- B keeping the material at a low temperature
- C using lead screening between the material and people
- D using the material for only a short time

40 A sample of a radioactive isotope has an initial rate of emission of 128 counts per minute and a half-life of 4 days.

How long will it take for the rate of emission to fall to 32 counts per minute?

- A 2 days B 4 days C 8 days D 12 days

BLANK PAGE

BLANK PAGE

BLANK PAGE

Permission to reproduce items where third-party owned material protected by copyright is included has been sought and cleared where possible. Every reasonable effort has been made by the publisher (UCLES) to trace copyright holders, but if any items requiring clearance have unwittingly been included, the publisher will be pleased to make amends at the earliest possible opportunity.

To avoid the issue of disclosure of answer-related information to candidates, all copyright acknowledgements are reproduced online in the Cambridge International Examinations Copyright Acknowledgements Booklet. This is produced for each series of examinations and is freely available to download at www.cie.org.uk after the live examination series.

Cambridge International Examinations is part of the Cambridge Assessment Group. Cambridge Assessment is the brand name of University of Cambridge Local Examinations Syndicate (UCLES), which is itself a department of the University of Cambridge.