

OCR

Oxford Cambridge and RSA

F

Wednesday 22 June 2016 – Morning

**GCSE GATEWAY SCIENCE
PHYSICS B****B752/01** Physics modules P4, P5, P6 (Foundation Tier)Candidates answer on the Question Paper.
A calculator may be used for this paper.**OCR supplied materials:**

None

Other materials required:

- Pencil
- Ruler (cm/mm)

Duration: 1 hour 30 minutes

Candidate forename		Candidate surname	
-----------------------	--	----------------------	--

Centre number						Candidate number				
---------------	--	--	--	--	--	------------------	--	--	--	--

INSTRUCTIONS TO CANDIDATES

- Write your name, centre number and candidate number in the boxes above. Please write clearly and in capital letters.
- Use black ink. HB pencil may be used for graphs and diagrams only.
- Answer **all** the questions.
- Read each question carefully. Make sure you know what you have to do before starting your answer.
- Write your answer to each question in the space provided. If additional space is required, you should use the lined page(s) at the end of this booklet. The question number(s) must be clearly shown.
- Do **not** write in the bar codes.

INFORMATION FOR CANDIDATES

- The quality of written communication is assessed in questions marked with a pencil (✎).
- A list of equations can be found on page 2.
- The number of marks is given in brackets [] at the end of each question or part question.
- The total number of marks for this paper is **85**.
- This document consists of **28** pages. Any blank pages are indicated.

2

EQUATIONS

$$\text{energy} = \text{mass} \times \text{specific heat capacity} \times \text{temperature change}$$

$$\text{energy} = \text{mass} \times \text{specific latent heat}$$

$$\text{efficiency} = \frac{\text{useful energy output} (\times 100\%)}{\text{total energy input}}$$

$$\text{wave speed} = \text{frequency} \times \text{wavelength}$$

$$\text{power} = \text{voltage} \times \text{current}$$

$$\text{energy supplied} = \text{power} \times \text{time}$$

$$\text{average speed} = \frac{\text{distance}}{\text{time}}$$

$$\text{distance} = \text{average speed} \times \text{time}$$

$$s = \frac{(u + v)}{2} \times t$$

$$\text{acceleration} = \frac{\text{change in speed}}{\text{time taken}}$$

$$\text{force} = \text{mass} \times \text{acceleration}$$

$$\text{weight} = \text{mass} \times \text{gravitational field strength}$$

$$\text{work done} = \text{force} \times \text{distance}$$

$$\text{power} = \frac{\text{work done}}{\text{time}}$$

$$\text{power} = \text{force} \times \text{speed}$$

$$\text{KE} = \frac{1}{2}mv^2$$

$$\text{momentum} = \text{mass} \times \text{velocity}$$

$$\text{force} = \frac{\text{change in momentum}}{\text{time}}$$

$$\text{GPE} = mgh$$

$$\text{resistance} = \frac{\text{voltage}}{\text{current}}$$

$$v = u + at$$

$$v^2 = u^2 + 2as$$

$$s = ut + \frac{1}{2}at^2$$

$$m_1u_1 + m_2u_2 = (m_1 + m_2)v$$

$$\text{refractive index} = \frac{\text{speed of light in vacuum}}{\text{speed of light in medium}}$$

$$\text{magnification} = \frac{\text{image size}}{\text{object size}}$$

$$l_e = l_b + l_c$$

$$\frac{\text{voltage across primary coil}}{\text{voltage across secondary coil}} =$$

$$\frac{\text{number of primary turns}}{\text{number of secondary turns}}$$

$$\text{power loss} = (\text{current})^2 \times \text{resistance}$$

$$V_p I_p = V_s I_s$$

Answer **all** the questions.

SECTION A – Module P4

1 Nuclear radiation is used in hospitals.

(a) Radioactive sources emit nuclear radiation.

They are used as tracers in the body.

Write down **one** other use of nuclear radiation in hospitals.

..... [1]

(b) The radiation from tracers needs to be detected outside the body.

Only two types of **nuclear** radiation can pass through the skin.

Which **two** types?

Choose your answers from:

alpha

beta

gamma

ultrasound

ultraviolet

answer and [2]

(c) Radiographers use nuclear radiation in hospitals.

Look at the radiographer. She is preparing a patient for treatment.



Suggest **two** different ways the radiographer can remain safe when the radiation is being emitted.

.....
.....
..... [2]

[Total: 5]

Turn over

2 Carly needs to attach a new mains plug to her hair dryer.



The hair dryer is a **double insulated** appliance.

She puts a 13 amp fuse in this plug.

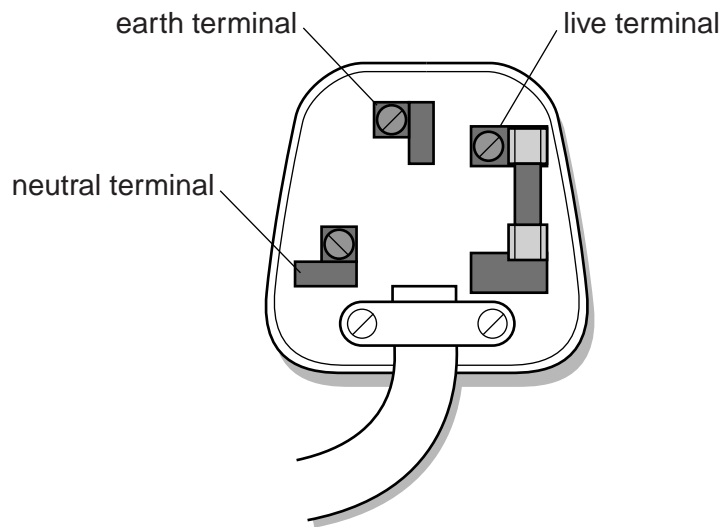

Write instructions for connecting the **two** different coloured wires needed in the plug.

Describe why it is important to use a 13 amp fuse.

You may draw on the diagram of the plug to help your answer.



The quality of written communication will be assessed in your answer to this question.

.....

.....

.....

.....

.....

.....

.....

.....

.....

5

.....

.....

..... [6]

[Total: 6]

3 This question is about static electricity.

(a) Bruno rubs a balloon on a piece of material.

He puts the balloon next to a water tap.

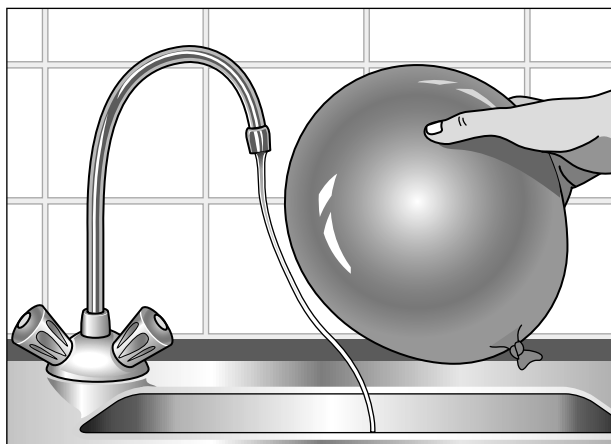

The stream of water bends towards the balloon.

Use ideas about static electricity to explain why.

.....

.....

.....

.....

..... [3]

(b) Designers are working on a pump that allows petrol to leave the pump quickly.



Static electricity can be dangerous when putting petrol in a car.

Suggest a **benefit** of this pump and a **risk** that needs to be considered by the designers.

.....

.....

..... [2]

4 Power stations are used to generate electricity.

(a) Look at the diagram of a power station that uses coal.

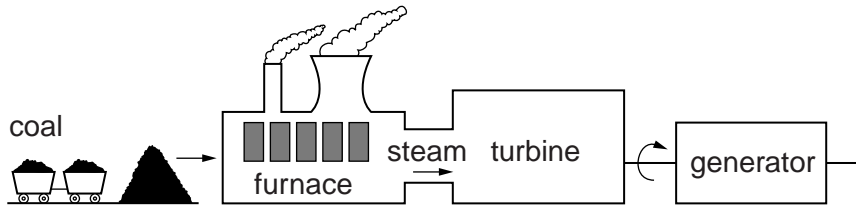

(i) Nuclear power stations have some **similarities** to coal power stations.

They both use a fuel.

Describe **one** other way they are similar.

..... [1]

(ii) Nuclear power stations have some **differences** to coal power stations.

Describe **one** way they are different.

..... [1]

(b) Complete the sentences.

Choose the best words from the list.

fission

fusion

joining

splitting

waste

The process that gives out energy in a nuclear power station is called nuclear

This involves the of nuclei. [2]

[Total: 4]

8

5 Victoria lives in the UK.

(a) She buys a new computer.

Look at the label on the adapter for the computer.

input voltage 230 V
output voltage 20 V
output current 4.7 A

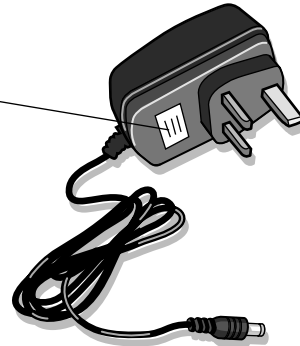

Calculate the **output power** of the adapter.

.....

.....

Output power W [2]

- (b) Victoria notices that different countries have different **input voltages** for home appliances.

Look at the information she finds on the internet.

Country	Input voltage in V
Bermuda	120
Kenya	240
Japan	100
Mexico	127
UK	230

Victoria has a travel iron.

The input voltage to the iron varies for different countries.

The iron is designed to keep the current the same in each country.

- (i) In which country does the iron have the most electrical power?

.....

Explain your answer.

.....

..... [1]

- (ii) The travel iron is not very good at getting the creases out of clothes when used in Japan. Use the information in the table to explain why.

.....

.....

..... [2]

[Total: 5]

SECTION B – Module P5

6 Scientists check the safety of cars by doing crash tests with crash dummies.

They use sensors to make measurements.

They put the sensors in the car and on the crash dummy.

Look at the diagram of a car crashing into a wall.

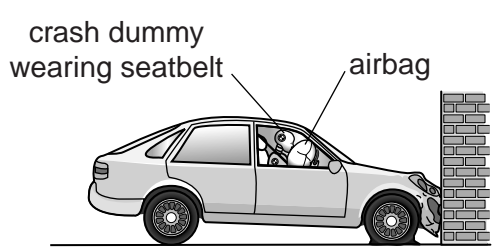

The crash dummy wears a seatbelt.

(a) Just after the crash the dummy moves forward. A force then acts on the dummy.

What produces this force and what does the force do to the dummy's motion?

.....
..... [1]

(b) On impact the airbag quickly inflates with gas.

Explain how the gas particles produce a pressure to inflate the airbag.

.....
.....
..... [2]

[Total: 3]

- 7 Some waves in the electromagnetic spectrum are used for communication.

Look at the table. It shows how waves of different wavelengths are used.

Typical wavelength in metres	Uses
100 000	Signals for shipping
10 000	Navigation
1 000	Long wave radio
10	Short wave radio
1	FM radio
0.1	Mobile phone
0.01	Satellite communications
0.001	Radio astronomy

- (a) Complete the sentence.

Choose from:

longitudinal sound transverse ultrasound

Waves in the electromagnetic spectrum are all waves. [1]

- (b) Some waves **in the table** above are reflected by the upper atmosphere.

- (i) Suggest a typical wavelength of waves that are reflected by the upper atmosphere.

..... metres [1]

- (ii) Suggest why this reflection is useful.

.....
 [1]

- (c) Waves of wavelength 0.01 m are used for satellite communication.

Suggest why.

.....
 [1]

12

(d) Two waves may produce **interference**.

Explain how interference of waves produces strong signals and weak signals.

.....

.....

..... [2]

[Total: 6]

8 Scientists have done experiments to find out about light.

(a) One idea about light is, 'light travels in straight lines'.

Write down **two** observations from the world around us that support this idea.

.....

.....

.....

..... [2]

(b) Look at the diagram. It shows white light entering a glass prism.

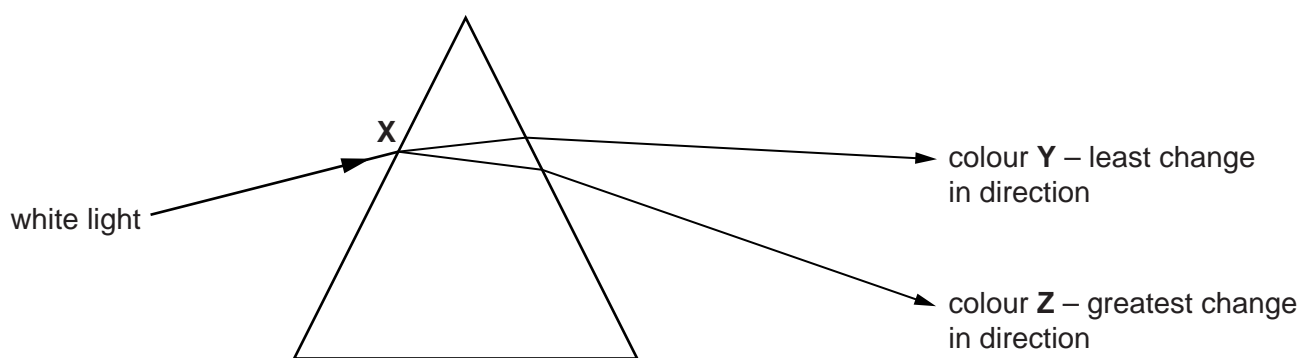

Dispersion happens and different colours are produced.

Complete the sentences.

Choose from:

- | | | |
|------------------|-----------------|--------------|
| diffracts | longest | red |
| reflects | refracts | same |
| shortest | violet | white |

When the light enters the prism at **X**, it

Colour **Z** is

Colour **Z** has the greatest change in direction because it has the wavelength.

[3]

[Total: 5]

- 9 Look at the diagrams, **V**, **W**, **X** and **Y**, each showing a rowing boat on different parts of a flowing river.

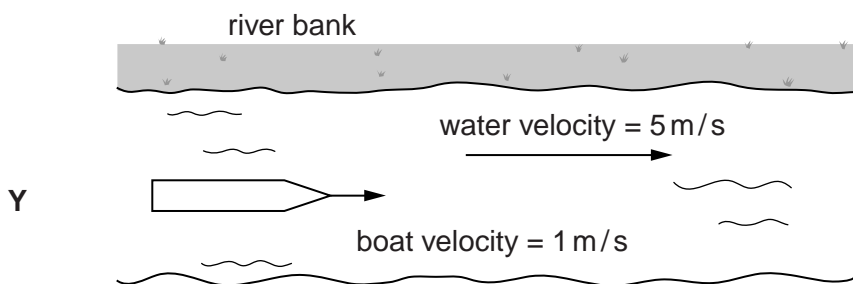
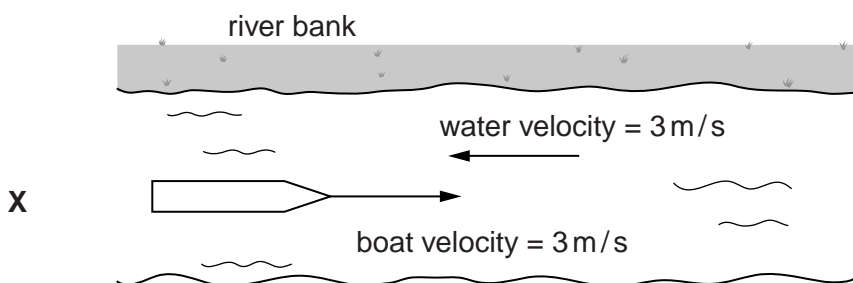
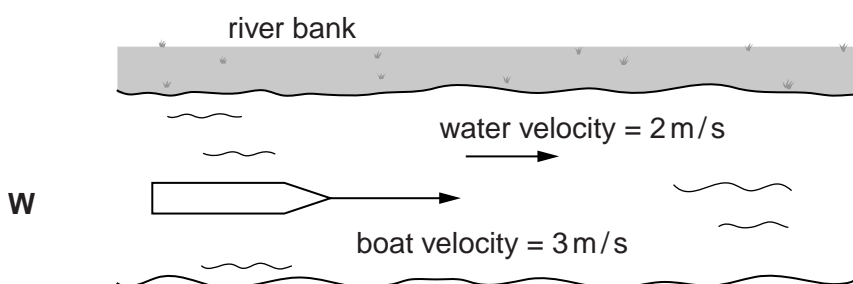
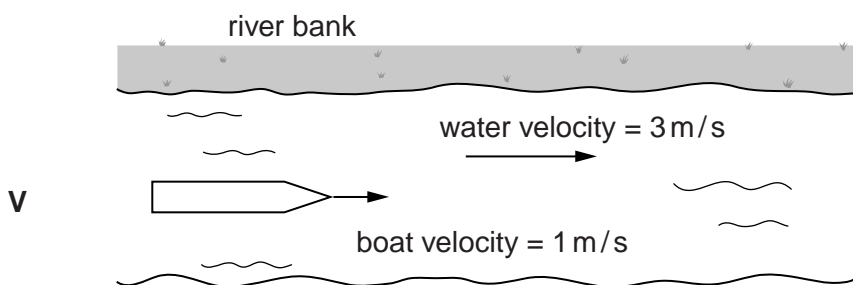

(a) The diagrams show the **velocities** of the boat and the water flow.

(i) What is the **difference** between speed and velocity?

.....
 [1]

(ii) Which boat has the largest **resultant** velocity as seen from the river bank?

Choose from **V, W, X** or **Y**.

.....
 Explain your answer.

 [2]

(b) A horse and rider are training for a race in a field.

The horse accelerates steadily from 2 m/s to 6 m/s.



It takes 7 s for the horse to accelerate.

Calculate the distance travelled by the horse for this acceleration.

.....

answer m [2]

[Total: 5]
 Turn over

SECTION C – Module P6

11 (a) Logic gates are used in many electronic devices.

(i) Draw the symbol for a NOT gate.

[1]

(ii) Complete the truth table for a NOT gate.

INPUT
0
1

[1]

(b) An LED can be used at the output of this logic gate.

A relay would be needed to switch on a large filament bulb.

(i) Explain why the LED can be used directly but the large filament bulb needs a relay.

.....

 [2]

(ii) Ahmed uses a logic gate in a warning device in a noisy factory.

Suggest an **advantage** and a **disadvantage** of using an LED for the output of the warning device.

.....

 [2]

[Total: 6]

18

12 Kevin connects a circuit with two resistors in series.

Look at the diagram.

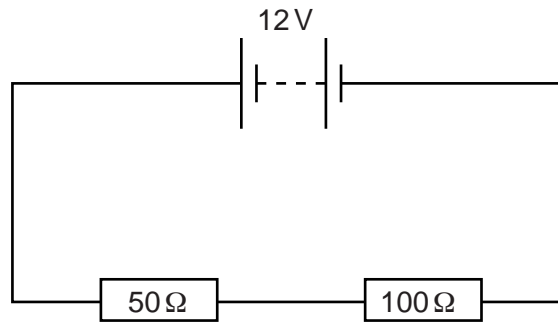

Jean says that Kevin could replace the two resistors with one resistor.

(a) What value of resistor could Kevin use to give the same total resistance?

.....

answer ohms [1]

(b) Kevin needs to split the output of the 12V battery between resistor R1 and resistor R2.

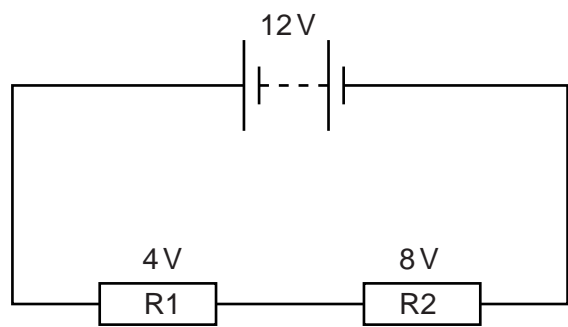

He needs 4V across R1 and 8V across R2.

He has four different pairs of resistors, **A**, **B**, **C** and **D** to choose from.

Pairs of resistors	R1 in Ω	R2 in Ω
A	50	200
B	50	100
C	50	50
D	50	25

Which pair of resistors, **A**, **B**, **C** or **D**, should he use?

.....

Explain your answer.

.....

.....

..... [2]

20

(c) Kevin needs a resistor of at least 5 ohms.

He finds a resistor without a value on it.

He decides to connect another circuit so that he can calculate the value of the resistor.

Look at the diagram.

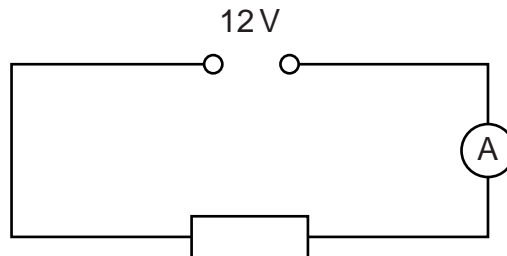

The ammeter shows a current of 3 A.

Use a calculation to find out if this resistor is suitable.

.....
.....

resistance = ohms

Is this resistor suitable?

[2]

[Total: 5]

21

13 Draw a line from each **circuit symbol** below to its correct **name**.

circuit symbol

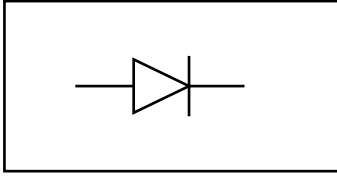

name

capacitor

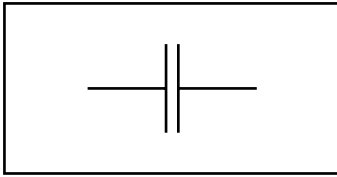

diode

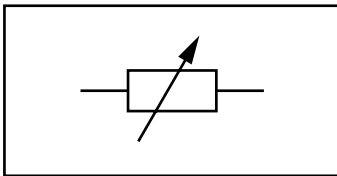

variable resistor

[2]

[Total: 2]

14 Filament bulbs are used to provide light in some homes and factories.

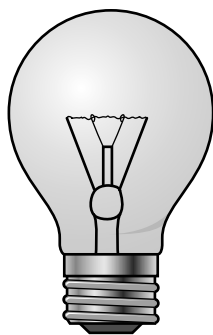

When the bulb is switched on, the resistance of the filament changes.

Explain how the resistance of the filament changes when a current passes through it.

Use ideas about atoms and electrical current to explain why this happens.



The quality of written communication will be assessed in your answer to this question.

.....

.....

.....

.....

.....

.....

.....

.....

.....

.....

.....

.....

.....

.....

.....

.....

.....

.....

.....

.....

..... [6]

[Total: 6]

15 This question is about alternating current (AC).

(a) What is the frequency of the mains electricity supply in the UK?

Tick (✓) the correct box.

5 Hz	<input type="checkbox"/>	50 Hz	<input type="checkbox"/>
10 Hz	<input type="checkbox"/>	100 Hz	<input type="checkbox"/>

[1]

(b) Look at the graph.

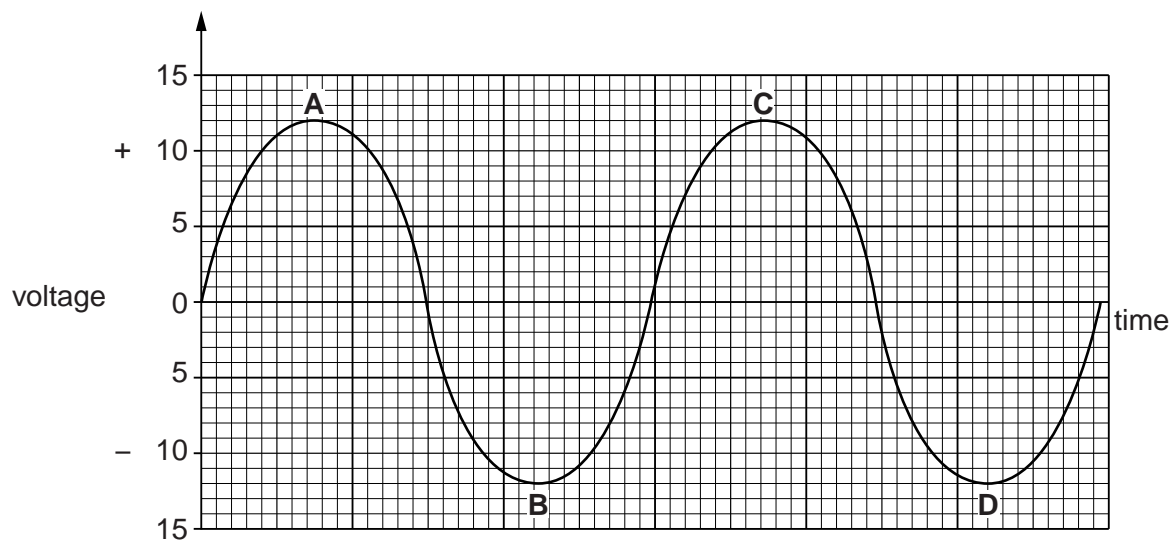

(i) State the maximum (peak) voltage of this AC supply.

..... V [1]

(ii) A diode can be used to produce half-wave rectification of this AC supply.

Explain how a diode produces half-wave rectification.

Use the letters, **A**, **B**, **C** and **D** on the graph to help you answer.

.....

.....

.....

..... [2]

[Total: 4]

16 This question is about transformers.

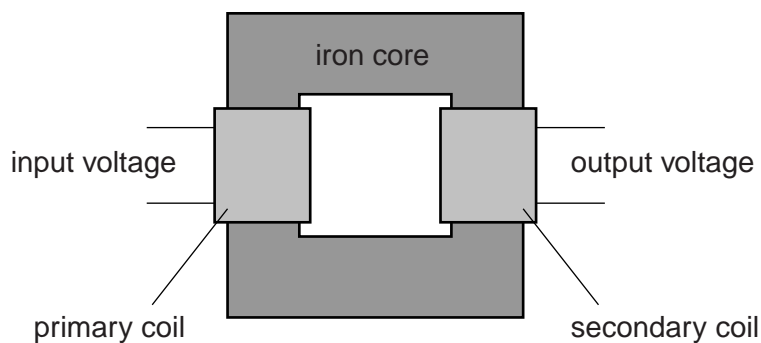

Transformers are used to change the voltage of an AC supply.

Susan has completed her homework on identifying step-up and step-down transformers.

	Input voltage in V	Output voltage in V	Step-up or step-down
A	10	20	Step-up
B	40	100	Step-down
C	25	50	Step-down
D	50	10	Step-down

Susan spots **two** mistakes in her work.

Which two rows, **A**, **B**, **C** or **D** are incorrect?

..... and

Explain your choices.

.....

.....

..... [2]

[Total: 2]

SECTION D

17 We use electricity to provide energy in our everyday activities.

(a) Look at the table.

It shows the average electrical energy in kWh used per person each day in different countries.

Country	Average electrical energy used per person each day in kWh
Austria	4.3
Belgium	6.2
Denmark	5.2
Finland	9.7
France	5.8
Germany	4.3
Ireland	4.6
Luxembourg	4.4
Norway	20.5
Sweden	12.9
Switzerland	5.8
UK	5.0

- (i) In the UK a person uses an average of 5.0 kWh of electrical energy each day.
How much would a family of 4 people use on average in 7 days?

.....
.....

answer kWh [2]

- (ii) Which countries in the table use the lowest amount of electrical energy per person each day?

.....
..... [2]

(iii) In Norway some people only use about 7 kWh of electrical energy each day. This is much less than the average amount of electrical energy used, which is 20.5 kWh. Suggest how these two figures can both be correct.

.....
 [1]

(iv) The average electrical energy use **per person** each day in the UK is less than that in Belgium. However, as a country, Belgium uses less electrical energy than the UK. Suggest a reason why.

.....
 [1]

(b) Energy can be lost through the walls of houses.

Different types of wall have different **U-values**. This is a measure of how much energy is lost through the wall.

Jenny's house has a single brick wall which has a U-value of $2.0 \text{ W/m}^2\text{ }^\circ\text{C}$. This means that every 1 m^2 of the wall, with a temperature difference of $1 \text{ }^\circ\text{C}$ across it, will lose 2.0 J of energy every second.

The side wall of Jenny's house has an area of 50 m^2 . In the winter, the average temperature difference between the inside of the house and the outside is $12 \text{ }^\circ\text{C}$.

(i) Calculate the energy lost through the wall each second for this temperature difference.

.....

 energy lost = unit = [3]

(ii) In a cold winter, the average temperature difference is greater than $12 \text{ }^\circ\text{C}$. How will this affect the energy lost each second through the wall?

.....
 [1]

[Total: 10]

END OF QUESTION PAPER

ADDITIONAL ANSWER SPACE

If additional space is required, you should use the following lined page(s). The question number(s) must be clearly shown in the margins.

A large area of the page is reserved for writing, consisting of 25 horizontal dotted lines. A solid vertical line runs down the left side of this area, creating a margin for writing the question number(s).

A large area of the page is reserved for writing, featuring a vertical solid line on the left side and horizontal dotted lines extending across the page.



Copyright Information

OCR is committed to seeking permission to reproduce all third-party content that it uses in its assessment materials. OCR has attempted to identify and contact all copyright holders whose work is used in this paper. To avoid the issue of disclosure of answer-related information to candidates, all copyright acknowledgements are reproduced in the OCR Copyright Acknowledgements Booklet. This is produced for each series of examinations and is freely available to download from our public website (www.ocr.org.uk) after the live examination series.

If OCR has unwittingly failed to correctly acknowledge or clear any third-party content in this assessment material, OCR will be happy to correct its mistake at the earliest possible opportunity.

For queries or further information please contact the Copyright Team, First Floor, 9 Hills Road, Cambridge CB2 1GE.

OCR is part of the Cambridge Assessment Group; Cambridge Assessment is the brand name of University of Cambridge Local Examinations Syndicate (UCLES), which is itself a department of the University of Cambridge.