

Centre Number	Candidate Number	Name
---------------	------------------	------

UNIVERSITY OF CAMBRIDGE INTERNATIONAL EXAMINATIONS
International General Certificate of Secondary Education

CHEMISTRY

0620/05

Paper 5 Practical Test

May/June 2004

1 hour 15 minutes

Candidates answer on the Question Paper.

Additional Materials: As listed in Instructions to Supervisors

READ THESE INSTRUCTIONS FIRST

Write your name, Centre number and candidate number in the spaces at the top of this page.

Write in dark blue or black pen in the spaces provided on the Question Paper.

You may use a pencil for any diagrams, graphs or rough working.

Do not use staples, paper clips, highlighters, glue or correction fluid.

You may use a calculator.

Answer **all** questions.

The number of marks is given in brackets [] at the end of each question or part questions.

Practical notes are provided on page 8.

If you have been given a label, look at the details. If any details are incorrect or missing, please fill in your correct details in the space given at the top of this page.

Stick your personal label here, if provided.

FOR EXAMINER'S USE

1

2

TOTAL

This document consists of **8** printed pages.



- 1 You are going to investigate the temperature changes that occur when two compounds, **A** and **B**, react with hydrochloric acid.

Read **all** the instructions below carefully before starting the experiments.

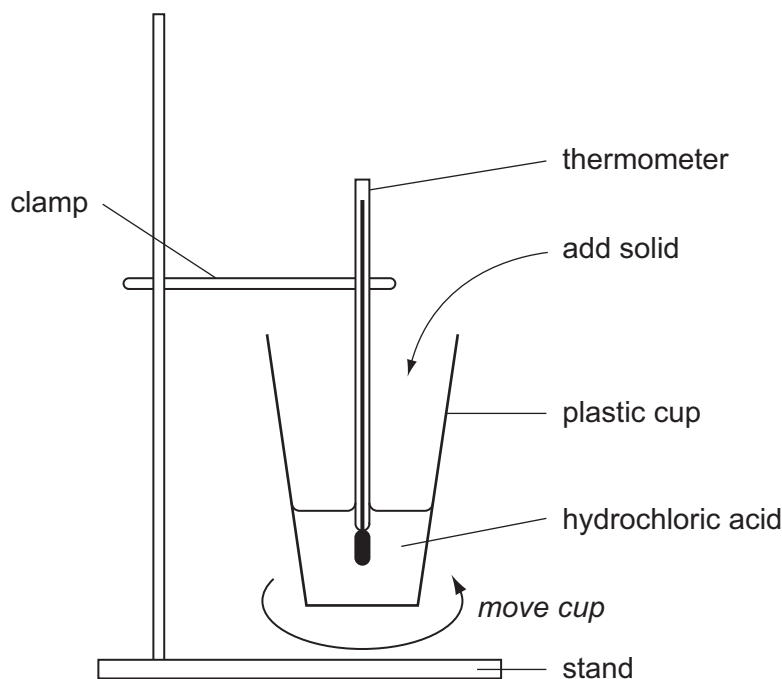

Instructions

Experiment 1

Using a measuring cylinder, add 30 cm^3 of the hydrochloric acid provided to the plastic cup.

In the table record the initial temperature of the acid.

Start the timer, and using a spatula, add some of the solid **A** to the cup. Stir the mixture by moving the cup (not the thermometer) until the fizzing stops (see diagram above). Now add some more of **A**. Continue adding **A** in this way until all of solid **A** has been added.

During the addition of **A**, record the temperature of the mixture every 30 seconds/half minute. It should take less than five minutes to add all of the solid. Continue taking temperature readings for the full five minutes.

Experiment 2

Using the second plastic cup provided, a fresh supply of hydrochloric acid and solid **B** (instead of **A**), repeat experiment 1.

*Table of results**Experiment 1*

time/minutes	0	0.5	1	1.5	2	2.5	3	3.5	4	4.5	5
temperature/°C											

[3]

Experiment 2

time/minutes	0	0.5	1	1.5	2	2.5	3	3.5	4	4.5	5
temperature/°C											

[3]

4

For
Examiner's
Use

- (a) Plot your results for both experiments on the grid below. For each set of results draw a smooth line graph. Indicate clearly which line represents Experiment 1 and which line Experiment 2.

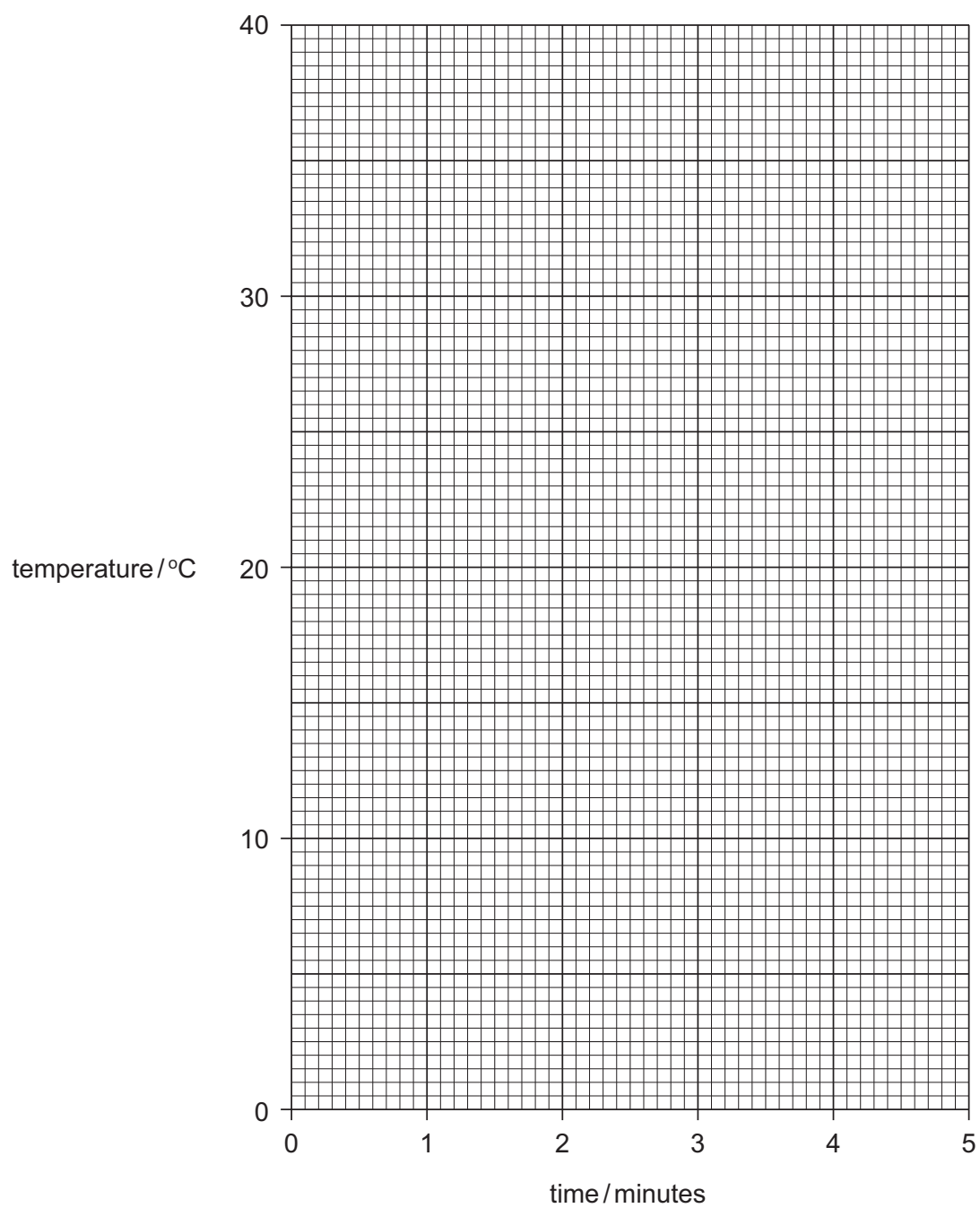

[7]

(b) From your graphs,

- (i) Find the temperature of the reaction mixture after the hydrochloric acid had reacted for 2 minutes 15 seconds with

solid **A**,

solid **B**. [2]

- (ii) What type of chemical reaction occurs when

solid **A**,

solid **B**. [2]

reacts with hydrochloric acid?

(c) Give two observations in Experiment 1, apart from temperature change.

1

2 [2]

(d) Suggest what type of compound solids **A** and **B** are. Explain your answer.

.....

..... [2]

(e) If the plastic cup and final reaction mixture were left for one hour, predict the temperature at this time for

- (i) solid **A** and hydrochloric acid,

.....

- (ii) solid **B** and hydrochloric acid.

.....

Explain your answers.

.....

..... [3]

- 2 You are provided with a mixture of two solid compounds **C** and **D**, containing the same metal cation.

C is partially soluble in water and **D** is soluble.

Carry out the following tests on **C** and **D**, recording **all** of your observations in the table. Do **not** write any conclusions in the table.

tests	observations
(a) Note the appearance of the mixture of C and D [1]
(b) Add the mixture of C and D to 10 cm ³ of distilled water in a boiling-tube. Stopper the tube and shake for 1 minute. Filter the mixture. Keep the filtrate.
(c) Divide the filtrate from (b) into five approximately equal portions.	
(i) To the first portion add drops of aqueous sodium hydroxide, a little at a time, with shaking. [2]
Add excess aqueous sodium hydroxide. [1]
(ii) To the second portion add excess aqueous ammonia, a little at a time. [1]
(iii) To the third portion add about 1 cm ³ of dilute sodium hydroxide and aluminium powder. Carefully boil the mixture and test the gas with damp indicator paper. [3]
(iv) Test the pH of the fourth portion with Indicator paper. [1]
(v) Using a straw blow into the fifth portion. [1]

(d) What conclusions can you draw about the identity of the metal cation in **C** and **D**?

.....
..... [1]

(e) Name the gas given off in (c)(iii).

..... [1]

(f) Suggest an explanation for the observation in (c)(v).

.....
..... [2]

(g) What conclusions can you draw about the identity of the anions in solid **C** and **D**?

.....
..... [2]

NOTES FOR USE IN QUALITATIVE ANALYSIS

Test for anions

<i>anion</i>	<i>test</i>	<i>test result</i>
carbonate (CO_3^{2-})	add dilute acid	effervescence, carbon dioxide produced
chloride (Cl^-) [in solution]	acidify with dilute nitric acid, then add aqueous silver nitrate	white ppt.
iodide (I^-) [in solution]	acidify with dilute nitric acid, then aqueous lead(II) nitrate	yellow ppt.
nitrate (NO_3^-) [in solution]	add aqueous sodium hydroxide then aluminium foil; warm carefully	ammonia produced
sulphate (SO_4^{2-}) [in solution]	acidify with dilute nitric acid, then aqueous barium nitrate	white ppt.

Test for aqueous cations

<i>cation</i>	<i>effect of aqueous sodium hydroxide</i>	<i>effect of aqueous ammonia</i>
aluminium (Al^{3+})	white ppt., soluble in excess giving a colourless solution	white ppt., insoluble in excess
ammonium (NH_4^+)	ammonia produced on warming	-
calcium (Ca^{2+})	white., insoluble in excess	no ppt., or very slight white ppt.
copper(Cu^{2+})	light blue ppt., insoluble in excess	light blue ppt., soluble in excess giving a dark blue solution
iron(II) (Fe^{2+})	green ppt., insoluble in excess	green ppt., insoluble in excess
iron(III) (Fe^{3+})	red-brown ppt., insoluble in excess	red-brown ppt., insoluble in excess
zinc (Zn^{2+})	white ppt., soluble in excess giving a colourless solution	white ppt., soluble in excess giving a colourless solution

Test for gases

<i>gas</i>	<i>test and test results</i>
ammonia (NH_3)	turns damp red litmus paper blue
carbon dioxide (CO_2)	turns limewater milky
chlorine (Cl_2)	bleaches damp litmus paper
hydrogen (H_2)	"pops" with a lighted splint
oxygen (O_2)	relights a glowing splint