

Please check the examination details below before entering your candidate information

Candidate surname					Other names			
Centre Number					Candidate Number			
Pearson Edexcel International GCSE (9–1)					<input type="text"/> <input type="text"/> <input type="text"/> <input type="text"/> <input type="text"/>			
Monday 11 January 2021								
Morning (Time: 2 hours)					Paper Reference 4CH1/1CR 4SD0/1CR			
Chemistry Unit: 4CH1 Science (Double Award) 4SD0 Paper: 1CR								
You must have: Calculator, ruler							Total Marks	

Instructions

- Use **black** ink or ball-point pen.
- **Fill in the boxes** at the top of this page with your name, centre number and candidate number.
- Answer **all** questions.
- Answer the questions in the spaces provided
– *there may be more space than you need.*
- Show all the steps in any calculations and state the units.
- Some questions must be answered with a cross in a box ☒. If you change your mind about an answer, put a line through the box ☒ and then mark your new answer with a cross ☒.

Information

- The total mark for this paper is 110.
- The marks for **each** question are shown in brackets
– *use this as a guide as to how much time to spend on each question.*

Advice

- Read each question carefully before you start to answer it.
- Write your answers neatly and in good English.
- Try to answer every question.
- Check your answers if you have time at the end.

Turn over ►

P67080A

©2021 Pearson Education Ltd.

1/1/1/



Pearson

The Periodic Table of the Elements

1	2	3	4	5	6	7	0										
7 Li lithium 3	9 Be beryllium 4	11 Na sodium 11	12 C carbon 6	13 Al aluminium 13	14 N nitrogen 7	15 O oxygen 8	16 F fluorine 9	17 Ne neon 10									
19 K potassium 19	20 Ca calcium 20	23 Na sodium 11	24 Mg magnesium 12	27 Al aluminium 13	28 Si silicon 14	31 P phosphorus 15	32 S sulfur 16	35.5 Cl chlorine 17	40 Ar argon 18								
39 K potassium 19	40 Ca calcium 20	45 Sc scandium 21	48 Ti titanium 22	51 V vanadium 23	52 Cr chromium 24	55 Mn manganese 25	56 Fe iron 26	59 Co cobalt 27	59 Ni nickel 28	63.5 Cu copper 29	65 Zn zinc 30	70 Ga gallium 31	73 Ge germanium 32	75 As arsenic 33	79 Se selenium 34	80 Br bromine 35	84 Kr krypton 36
85 Rb rubidium 37	88 Sr strontium 38	89 Y yttrium 39	91 Zr zirconium 40	93 Nb niobium 41	96 Mo molybdenum 42	[98] Tc technetium 43	101 Ru ruthenium 44	103 Rh rhodium 45	106 Pd palladium 46	108 Ag silver 47	112 Cd cadmium 48	115 In indium 49	119 Sn tin 50	122 Sb antimony 51	127 I iodine 53	131 Xe xenon 54	[222] Rn radon 86
133 Cs caesium 55	137 Ba barium 56	139 La* lanthanum 57	178 Hf hafnium 72	181 Ta tantalum 73	184 W tungsten 74	186 Re rhenium 75	190 Os osmium 76	192 Ir iridium 77	195 Pt platinum 78	197 Au gold 79	201 Hg mercury 80	204 Tl thallium 81	207 Pb lead 82	209 Bi bismuth 83	[210] At astatine 85	[209] Po polonium 84	[222] Rn radon 86
[223] Fr francium 87	[226] Ra radium 88	[227] Ac* actinium 89	[261] Rf rutherfordium 104	[262] Db dubnium 105	[266] Sg seaborgium 106	[264] Bh bohrium 107	[277] Hs hassium 108	[268] Mt meitnerium 109	[271] Ds darmstadtium 110	[272] Rg roentgenium 111	Elements with atomic numbers 112–116 have been reported but not fully authenticated						

1	H hydrogen 1
---	---------------------------

relative atomic mass
atomic symbol
name
atomic (proton) number

* The lanthanoids (atomic numbers 58–71) and the actinoids (atomic numbers 90–103) have been omitted.

The relative atomic masses of copper and chlorine have not been rounded to the nearest whole number.

DO NOT WRITE IN THIS AREA

DO NOT WRITE IN THIS AREA

DO NOT WRITE IN THIS AREA



Answer ALL questions.

1 The box lists some substances.

air	bromine	carbon	copper	glucose
nitrogen	oxygen	sulfur	water	

Choose substances from the box to answer these questions.

Each substance may be used once, more than once or not at all.

(a) Name a metallic element. (1)

(b) Name a compound. (1)

(c) Name a mixture. (1)

(d) Name an element that is a gas at room temperature. (1)

(e) Name an element that forms a basic oxide. (1)

(f) Name two elements that are in the same group of the Periodic Table. (1)

(Total for Question 1 = 6 marks)

DO NOT WRITE IN THIS AREA

DO NOT WRITE IN THIS AREA

DO NOT WRITE IN THIS AREA



2 A student does a chromatography experiment using ink 1, ink 2, and three known dyes A, B and C. The student uses water as the solvent.

The diagram shows the student's chromatogram.

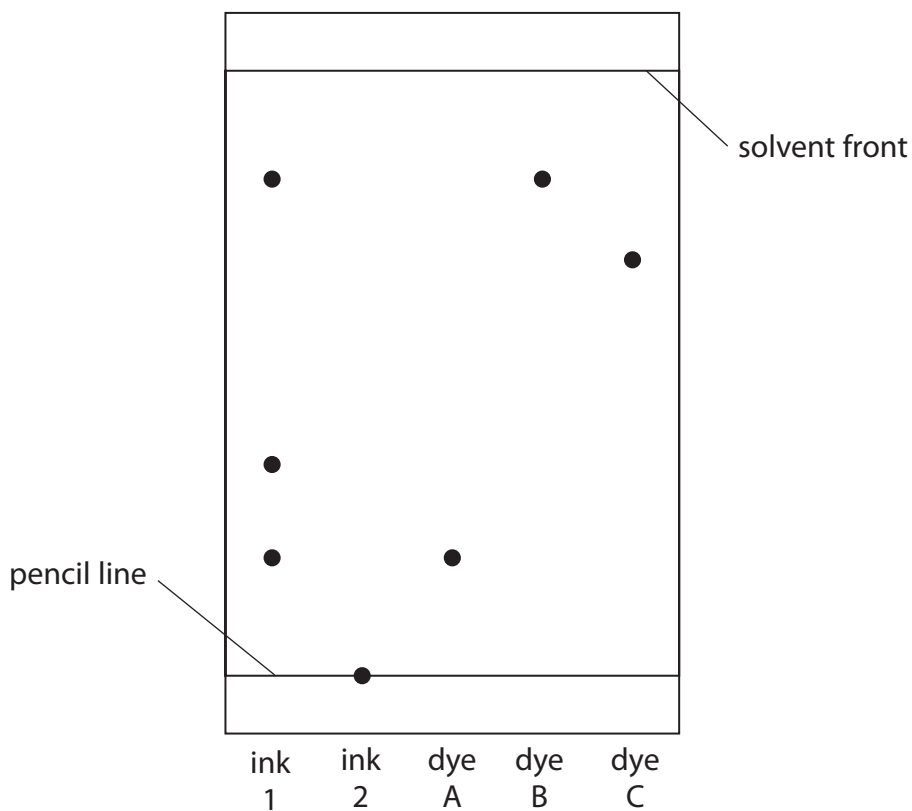

(a) Deduce what conclusions can be made about the composition of ink 1.

(2)

.....

.....

.....

.....

(b) (i) Give one conclusion that can be made about ink 2.

(1)

.....

.....

DO NOT WRITE IN THIS AREA

DO NOT WRITE IN THIS AREA

DO NOT WRITE IN THIS AREA



(ii) Suggest how the student could change the experiment to find the composition of ink 2.

(1)

(c) Calculate the R_f value of dye C, giving your answer to 2 significant figures.

(3)

R_f value =

(Total for Question 2 = 7 marks)

DO NOT WRITE IN THIS AREA

DO NOT WRITE IN THIS AREA

DO NOT WRITE IN THIS AREA



P 6 7 0 8 0 A 0 5 3 2

3 Crude oil is a mixture of organic compounds.

Most of these compounds are members of the same homologous series.

(a) State the name of this homologous series.

(1)

(b) An industrial process is used to separate crude oil into fractions.

(i) The process depends on a difference in a property of the fractions.

What is this property?

(1)

- A boiling point
- B density
- C melting point
- D solubility

(ii) The boxes give some uses of fractions and some names of fractions.

Draw one straight line from each use to its correct fraction.

(3)

Use	Fraction
fuel for aeroplanes	bitumen
fuel for ships	diesel
surfacing roads	fuel oil
	gasoline
	kerosene

DO NOT WRITE IN THIS AREA

DO NOT WRITE IN THIS AREA

DO NOT WRITE IN THIS AREA



(c) Fuels obtained from the fractions may contain impurities.

Explain how the combustion of a common impurity in fuels may cause an environmental problem.

(3)

.....

.....

.....

.....

.....

.....

(d) Some of the fractions contain long-chain molecules which are not very useful.

(i) Give the name of the process used to convert long-chain molecules into more useful shorter-chain molecules.

(1)

.....

(ii) Give the catalyst and temperature used in the industrial process to convert long-chain molecules into shorter-chain molecules.

(2)

catalyst

temperature

(iii) When $C_{13}H_{28}$ is used in this process, three different molecules are formed.

Complete the equation for this reaction.

(2)



(Total for Question 3 = 13 marks)

DO NOT WRITE IN THIS AREA

DO NOT WRITE IN THIS AREA

DO NOT WRITE IN THIS AREA



4 When iron is left in damp air, rust forms on its surface.

(a) (i) State the chemical name for rust.

(1)

(ii) Explain how a barrier method prevents rusting.

(2)

DO NOT WRITE IN THIS AREA

DO NOT WRITE IN THIS AREA

DO NOT WRITE IN THIS AREA

(b) A student uses this apparatus to find the approximate percentage by volume of oxygen in air.

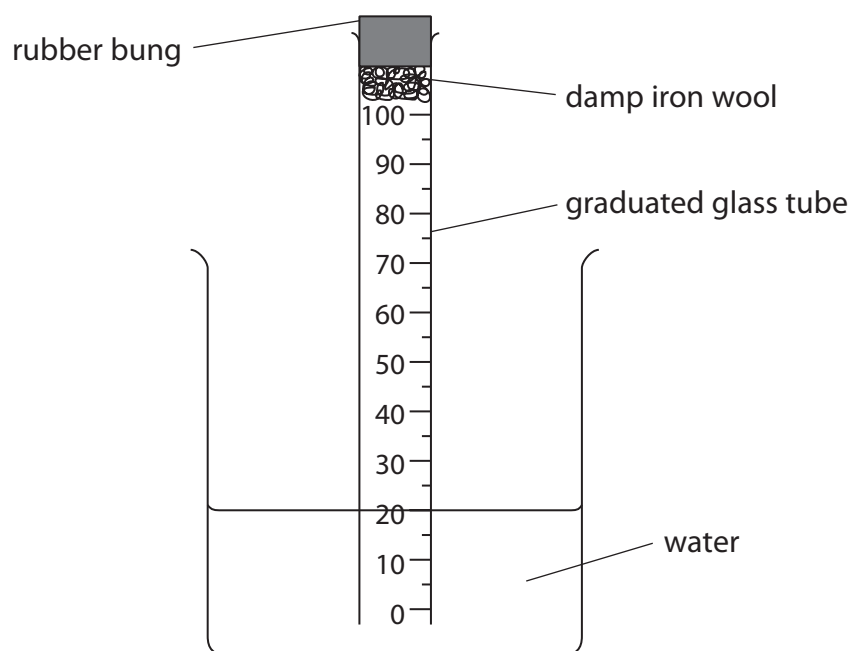

This is the student's method.

- place a graduated glass tube in a beaker of water
- place some damp iron wool and a rubber bung in the top of the tube
- record the reading of the water level in the tube
- leave the apparatus for a few days
- record the reading of the water level again

The diagram shows the readings at the start and at the end of the experiment.

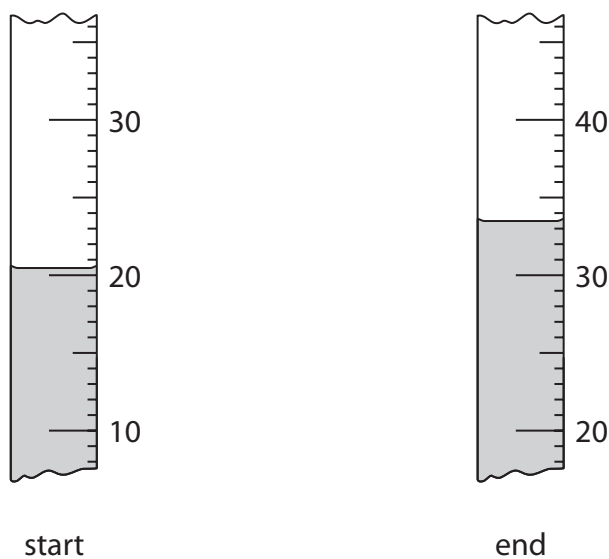

- (i) Use the readings to complete the table, giving all values to the nearest 0.5 cm³.

(2)

reading at start in cm ³	20.5
reading at end in cm ³	
volume of oxygen used in cm ³	

- (ii) The student uses these results to calculate the percentage by volume of oxygen in air.

Suggest why her calculated value is lower than the expected value.

(1)

.....

.....

.....



(c) The student repeats the experiment using the same apparatus.

These are her results for the second experiment.

volume of air in tube at start = 80.0 cm^3

reading at start = 20.0

reading at end = 35.5

Use the results to calculate the percentage by volume of oxygen in air.

(3)

percentage = %

(Total for Question 4 = 9 marks)



DO NOT WRITE IN THIS AREA

DO NOT WRITE IN THIS AREA

DO NOT WRITE IN THIS AREA

BLANK PAGE



- 5 A student uses this apparatus to investigate the effect of heat on different solid metal carbonates.

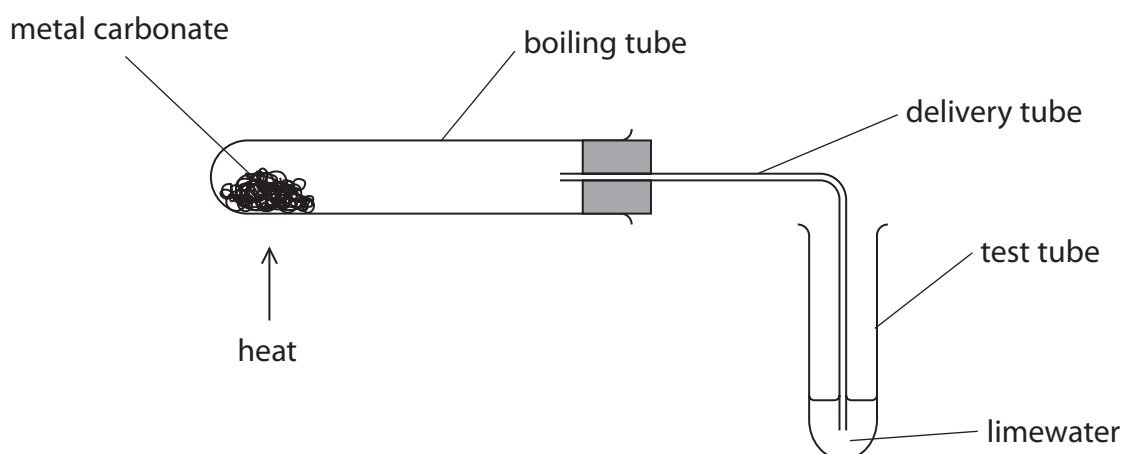

This is the student's method.

- use a spatula to put some metal carbonate in the boiling tube
- fit the delivery tube into position
- pour some limewater into the test tube
- start a timer and immediately begin to heat the metal carbonate
- record the time when a change first occurs in the limewater

The student repeats the method using different metal carbonates.

When a metal carbonate is heated a reaction sometimes occurs.

The equation for the reaction is



DO NOT WRITE IN THIS AREA

DO NOT WRITE IN THIS AREA

DO NOT WRITE IN THIS AREA



(a) State the name given to this type of reaction.

(1)

(b) State two variables that the student should control in this investigation.

(2)

1

2

(c) Suggest why bubbles appear in the limewater immediately after heating has started but before there is any change to the metal carbonate.

(1)

(d) Explain the purpose of limewater in this investigation.

(2)

DO NOT WRITE IN THIS AREA

DO NOT WRITE IN THIS AREA

DO NOT WRITE IN THIS AREA



P 6 7 0 8 0 A 0 1 3 3 2

(e) The table shows some of the results for the student's investigation.

Metal carbonate	Colour change of solid	Time taken for any change in limewater
calcium carbonate	remains white	90 seconds
sodium carbonate	remains white	no change
copper(II) carbonate		50 seconds

(i) State the colour change that occurs for copper(II) carbonate. (2)

from to

(ii) Give a chemical equation for this reaction of copper(II) carbonate. (1)

(f) (i) There is a relationship between the position of a metal in the reactivity series and how easily the metal carbonate reacts when heated.

Use the student's results and your own knowledge to deduce this relationship. (2)

(ii) State how you should extend the investigation to see if your deduction is correct. (1)

(Total for Question 5 = 12 marks)



DO NOT WRITE IN THIS AREA

DO NOT WRITE IN THIS AREA

DO NOT WRITE IN THIS AREA

BLANK PAGE



6 Zinc reacts with dilute hydrochloric acid to form hydrogen.

(a) (i) Give a chemical equation for this reaction.

(2)

(ii) Give a test for hydrogen gas.

(1)

(b) A student investigates the reaction between pieces of zinc and dilute hydrochloric acid.

In each experiment, he uses the same mass of zinc but a different volume of the acid.

He collects the hydrogen and measures its volume in each experiment.

The graph shows the student's results.

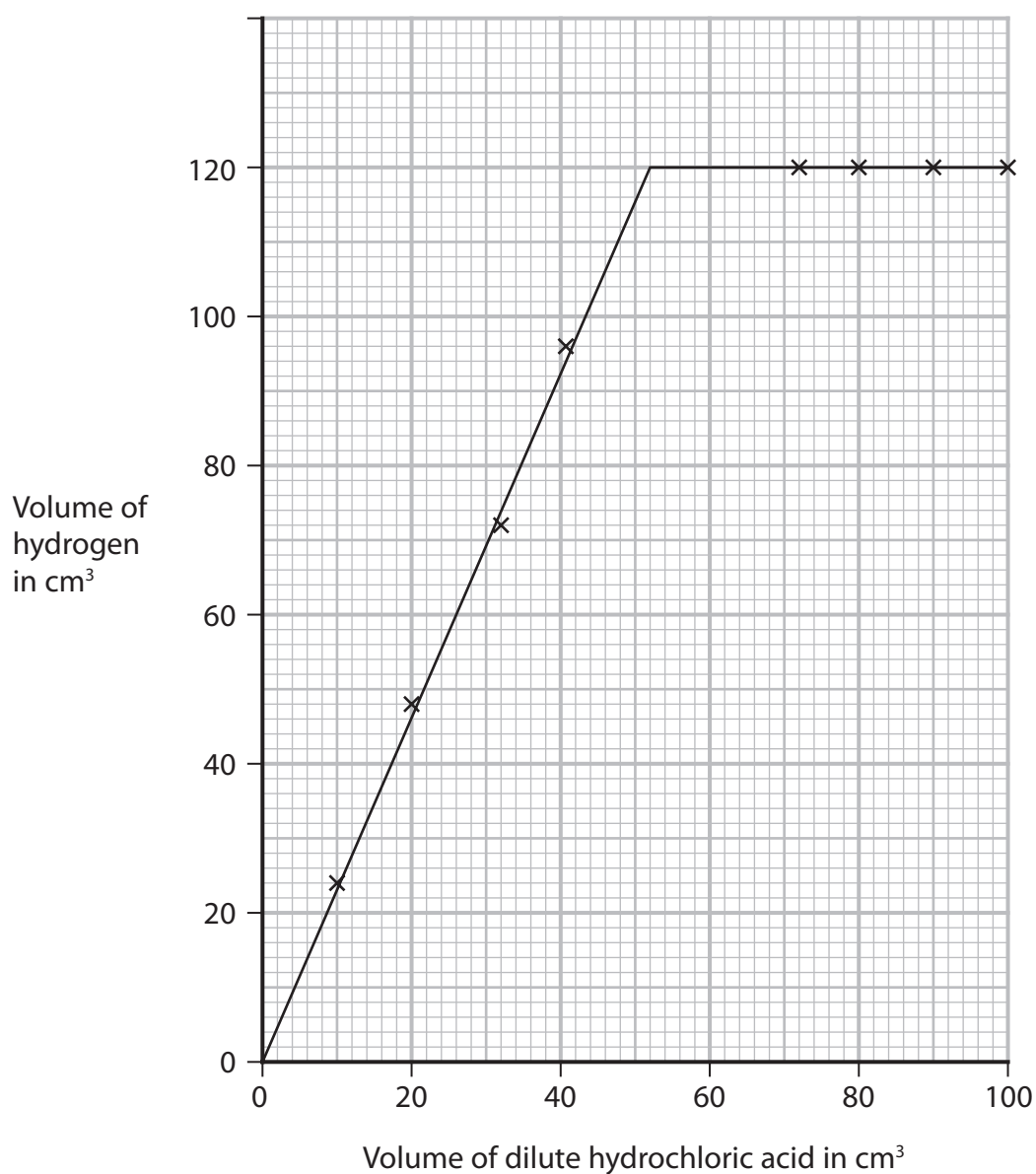

DO NOT WRITE IN THIS AREA

DO NOT WRITE IN THIS AREA

DO NOT WRITE IN THIS AREA



DO NOT WRITE IN THIS AREA

DO NOT WRITE IN THIS AREA

DO NOT WRITE IN THIS AREA

(i) Use the graph to find the minimum volume of acid needed to react with all of the zinc.

(1)

(ii) The student repeats the investigation, using hydrochloric acid of double the original concentration.

Determine the volume of hydrogen that would be collected using 15 cm³ of this acid.

Show your working on the graph.

(2)

volume = cm³

(c) Explain how increasing the concentration of the hydrochloric acid affects the rate of reaction.

(3)

.....

.....

.....

.....

.....

.....

.....

.....

.....

.....



(d) The rate of reaction could also be affected by changing the temperature of the hydrochloric acid, or by using a catalyst.

Explain one other way in which the rate of reaction between zinc and hydrochloric acid can be affected.

(3)

.....

.....

.....

.....

.....

.....

.....

.....

.....

.....

.....

.....

.....

.....

.....

(Total for Question 6 = 12 marks)

DO NOT WRITE IN THIS AREA

DO NOT WRITE IN THIS AREA

DO NOT WRITE IN THIS AREA



DO NOT WRITE IN THIS AREA

DO NOT WRITE IN THIS AREA

DO NOT WRITE IN THIS AREA

BLANK PAGE



7 The formation of ions and covalent bonds involves electrons.

The table gives the electronic configurations of atoms of hydrogen, lithium and chlorine.

Element	Electronic configuration of atom
hydrogen	1
lithium	2.1
chlorine	2.8.7

(a) Describe the different roles of electrons in the formation of

- ions in lithium chloride
- covalent bonds in hydrogen chloride

(3)

.....

.....

.....

.....

.....

.....

.....

.....

.....

.....

DO NOT WRITE IN THIS AREA

DO NOT WRITE IN THIS AREA

DO NOT WRITE IN THIS AREA



- 8 (a) (i) Organic compounds can exist as isomers.

Explain what is meant by the term **isomers**.

(2)

.....

.....

.....

- (ii) Organic compound Q reacts with bromine, without the presence of ultraviolet radiation, to form the compound $C_4H_8Br_2$

Draw the displayed formulae of two isomers of Q.

(2)

--	--

- (b) An acrylic polymer can be formed from molecules with this structure.

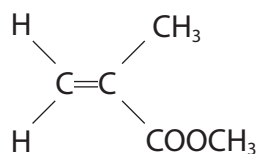

- (i) A student describes the molecule as an unsaturated hydrocarbon.

Explain whether this is a correct description.

(2)

.....

.....

.....

- (ii) Name the type of polymerisation that occurs in the formation of the polymer.

(1)

.....



(iii) Complete the equation for the polymerisation reaction.

(2)

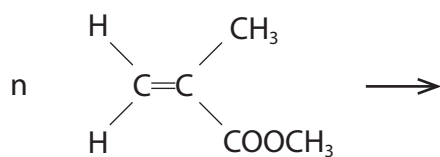

(c) Octane is a compound in petrol.

The equation for the complete combustion of octane is

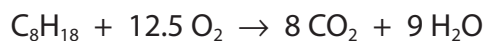

(i) The fuel tank of a car contains 50.0 dm³ of octane.

Calculate the mass, in kg, of carbon dioxide formed if all the octane in the fuel tank undergoes complete combustion.

[mass of 1 dm³ of octane = 700 g]

(5)

mass =kg

(ii) State an environmental problem caused by carbon dioxide.

(1)

(Total for Question 8 = 15 marks)



DO NOT WRITE IN THIS AREA

DO NOT WRITE IN THIS AREA

DO NOT WRITE IN THIS AREA

BLANK PAGE



9 Lithium, sodium and potassium are the first three elements in Group 1 of the Periodic Table.

(a) Suggest why these three elements are all stored in paraffin oil.

(1)

.....

.....

.....

(b) Caesium, Cs, is below potassium in Group 1.

(i) Give a similarity and a difference between the reactions of potassium with water and caesium with water.

(2)

similarity.....

.....

difference.....

.....

(ii) Give the chemical equation for the reaction between caesium and water.

(2)

.....

DO NOT WRITE IN THIS AREA

DO NOT WRITE IN THIS AREA

DO NOT WRITE IN THIS AREA



- (c) A student investigates the temperature change in the reaction between dilute acids and solutions of Group 1 hydroxides.

He uses this apparatus.

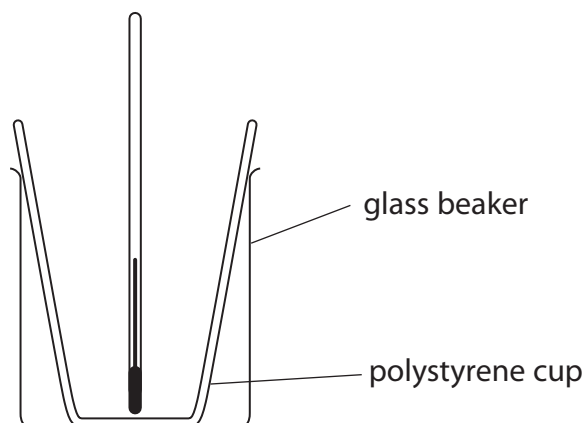

This is the student's method.

- measure the temperature of 50 cm^3 of hydrochloric acid
- pour the acid into a polystyrene cup
- add 50 cm^3 of sodium hydroxide solution to the acid
- measure the maximum temperature of the mixture

- (i) Suggest what could be added to the apparatus to improve the experiment.

(1)

- (ii) Explain a change to the method that would improve the accuracy of the experiment.

(2)



(d) These are the student's results.

temperature of hydrochloric acid = 19.9 °C

maximum temperature of mixture = 26.5 °C

(i) Calculate the energy change, Q , in joules for this reaction.

[mass of 1.0 cm³ of mixture = 1.0 g]

[for the mixture, $c = 4.2 \text{ J/g/}^\circ\text{C}$]

(3)

$Q = \dots\dots\dots \text{ J}$

(ii) In the student's reaction between hydrochloric acid and sodium hydroxide, 0.050 mol of water forms.

Calculate the molar enthalpy change, ΔH , in kJ/mol for this reaction.

(2)

$\Delta H = \dots\dots\dots \text{ kJ/mol}$

(Total for Question 9 = 13 marks)

DO NOT WRITE IN THIS AREA

DO NOT WRITE IN THIS AREA

DO NOT WRITE IN THIS AREA



10 This question is about salts.

(a) Soluble salts can be prepared by the reaction between a metal oxide and an acid.

The equation for this type of reaction is



(i) State the name given to this type of reaction.

(1)

(ii) State, in terms of protons, what happens in this reaction.

(1)

(b) (i) A student is given 50 cm³ of dilute sulfuric acid and a bottle of solid copper(II) carbonate.

Describe the method that the student should use to prepare a saturated solution of copper(II) sulfate.

In your answer, refer to the pieces of apparatus that the student should use.

(5)

DO NOT WRITE IN THIS AREA

DO NOT WRITE IN THIS AREA

DO NOT WRITE IN THIS AREA



- (ii) The student produces dry crystals of hydrated copper(II) sulfate from the saturated solution.

He calculates that 6.40 g of dry crystals should be formed.

The mass of dry crystals he actually obtains is 1.80 g less than he calculated.

Calculate the student's percentage yield.

Give your answer to one decimal place.

(3)

percentage yield = %

DO NOT WRITE IN THIS AREA

DO NOT WRITE IN THIS AREA

DO NOT WRITE IN THIS AREA



P 6 7 0 8 0 A 0 2 9 3 2

(c) (i) Gypsum is hydrated calcium sulfate.

A sample of gypsum contains 79% of calcium sulfate by mass.

Calculate the value of x in $\text{CaSO}_4 \cdot x\text{H}_2\text{O}$

[M_r of $\text{CaSO}_4 = 136$ M_r of $\text{H}_2\text{O} = 18$]

(3)

$x = \dots\dots\dots$

(ii) Describe a test for calcium ions in the sample of gypsum.

(2)

.....

.....

.....

.....

(Total for Question 10 = 15 marks)

TOTAL FOR PAPER = 110 MARKS



DO NOT WRITE IN THIS AREA

DO NOT WRITE IN THIS AREA

DO NOT WRITE IN THIS AREA

BLANK PAGE



DO NOT WRITE IN THIS AREA

DO NOT WRITE IN THIS AREA

DO NOT WRITE IN THIS AREA

BLANK PAGE

